

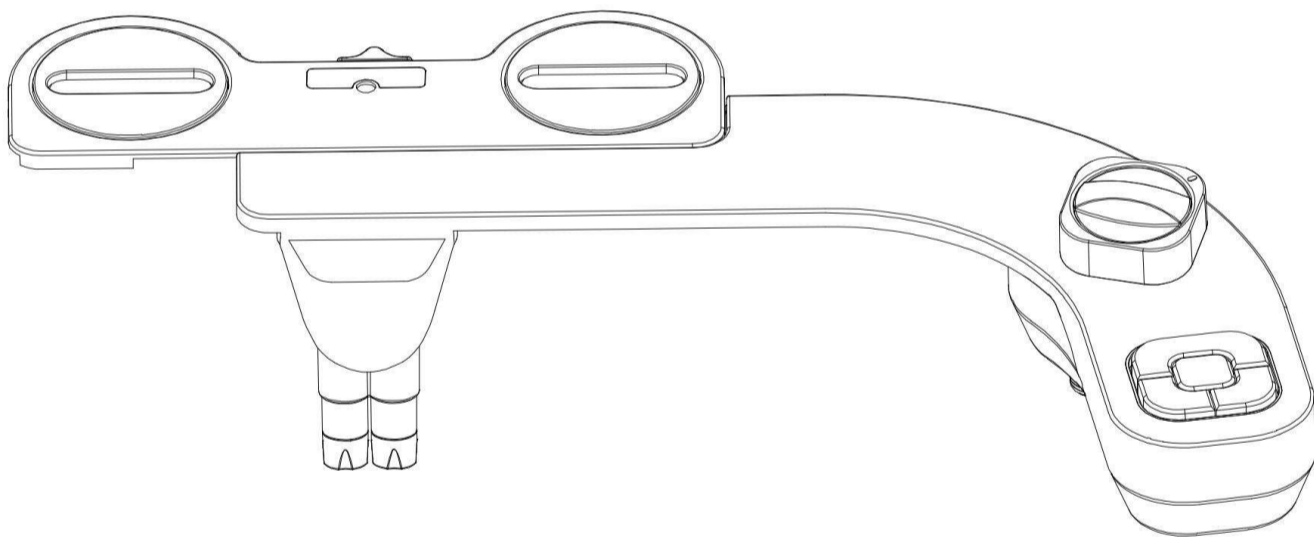

INSTRUCTION MANUAL

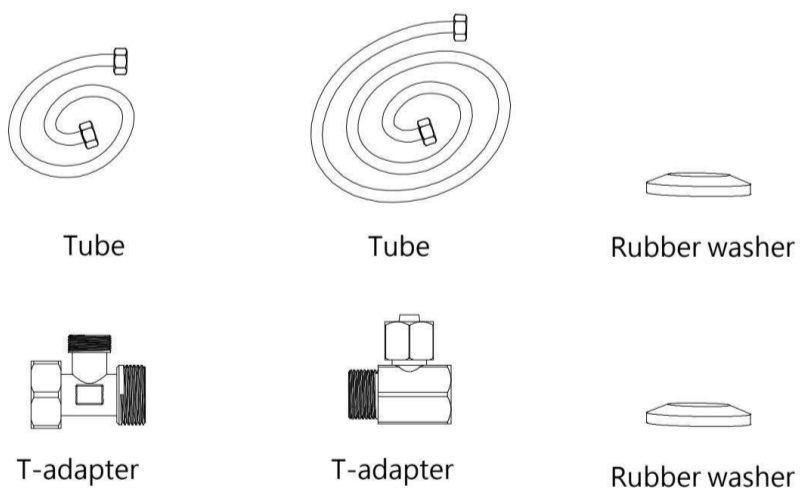

Names And Functions Of Parts

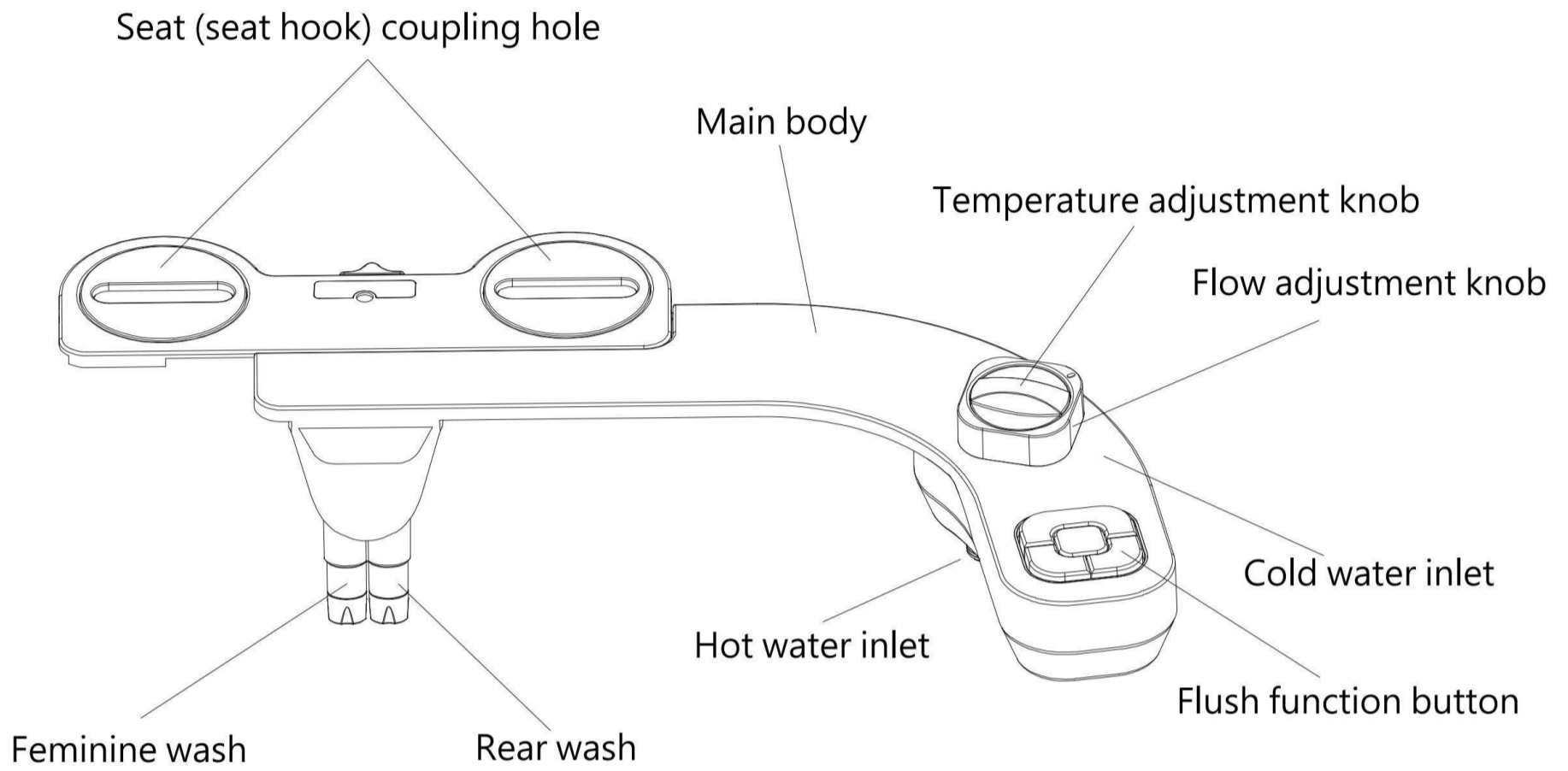

Installation Tools Needed	
	
Wrench	Screwdriver

Install The Bidet

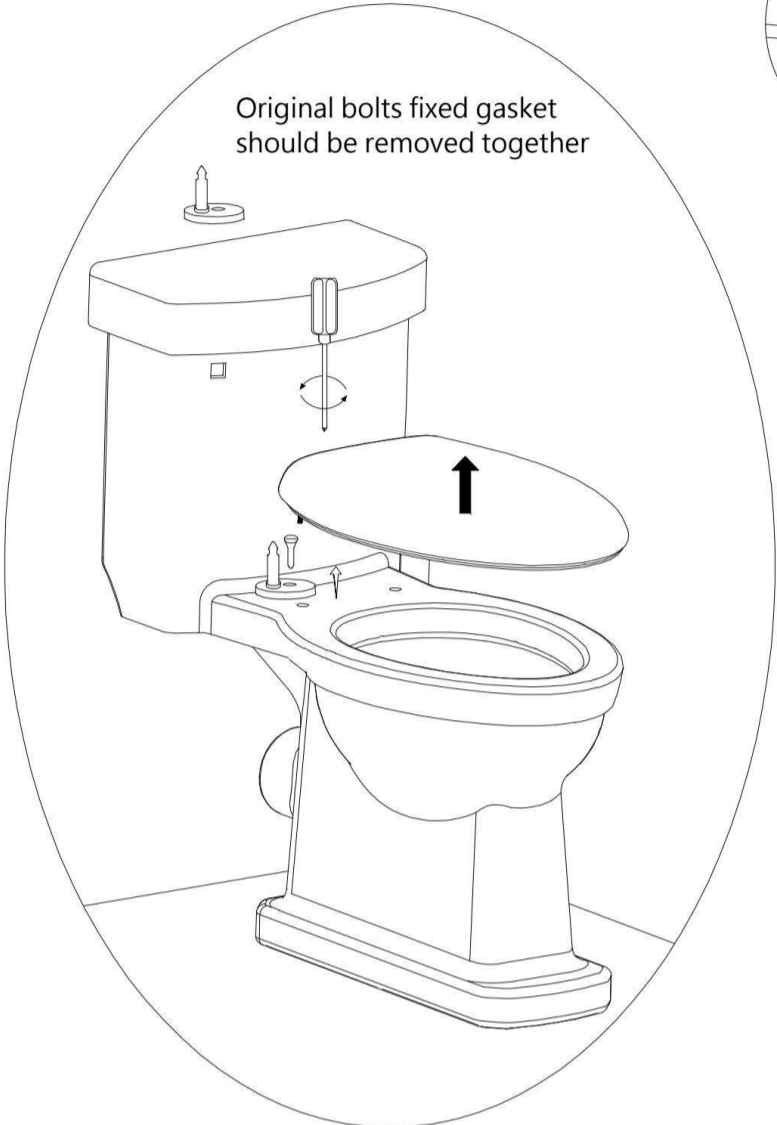

a

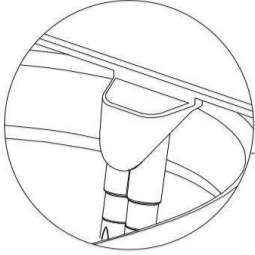

Adjust the nozzle position and try to make it close to the rim of the toilet.

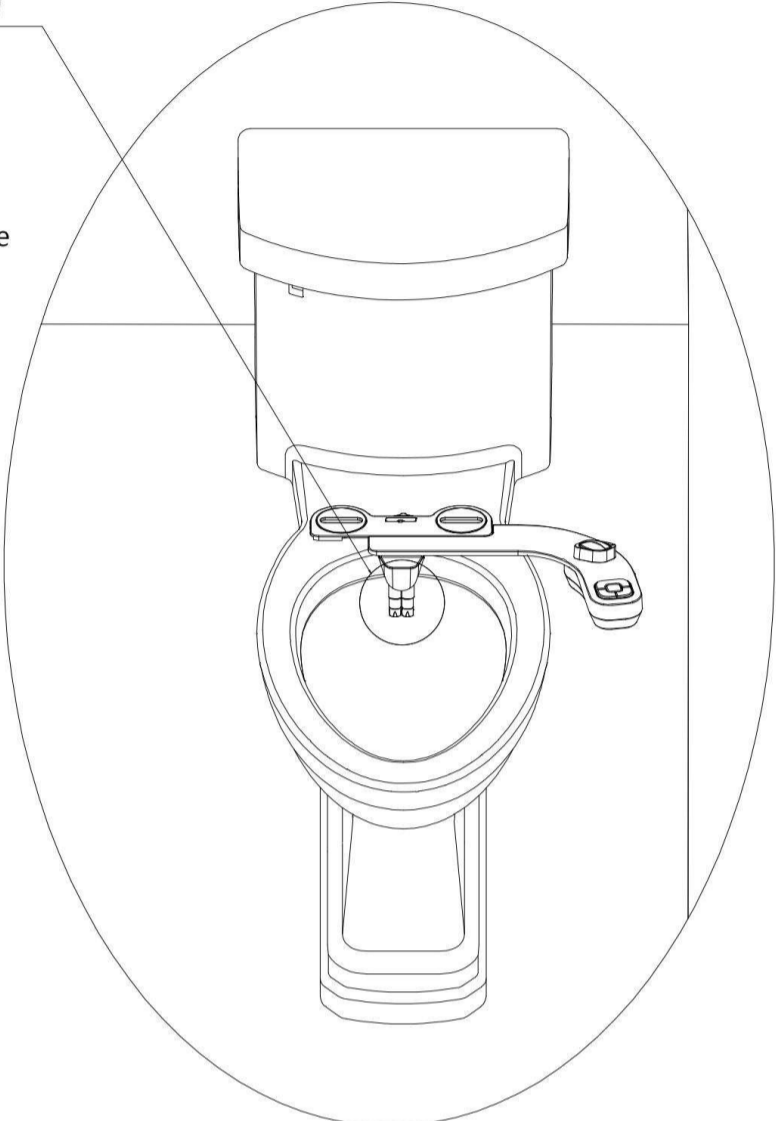

b

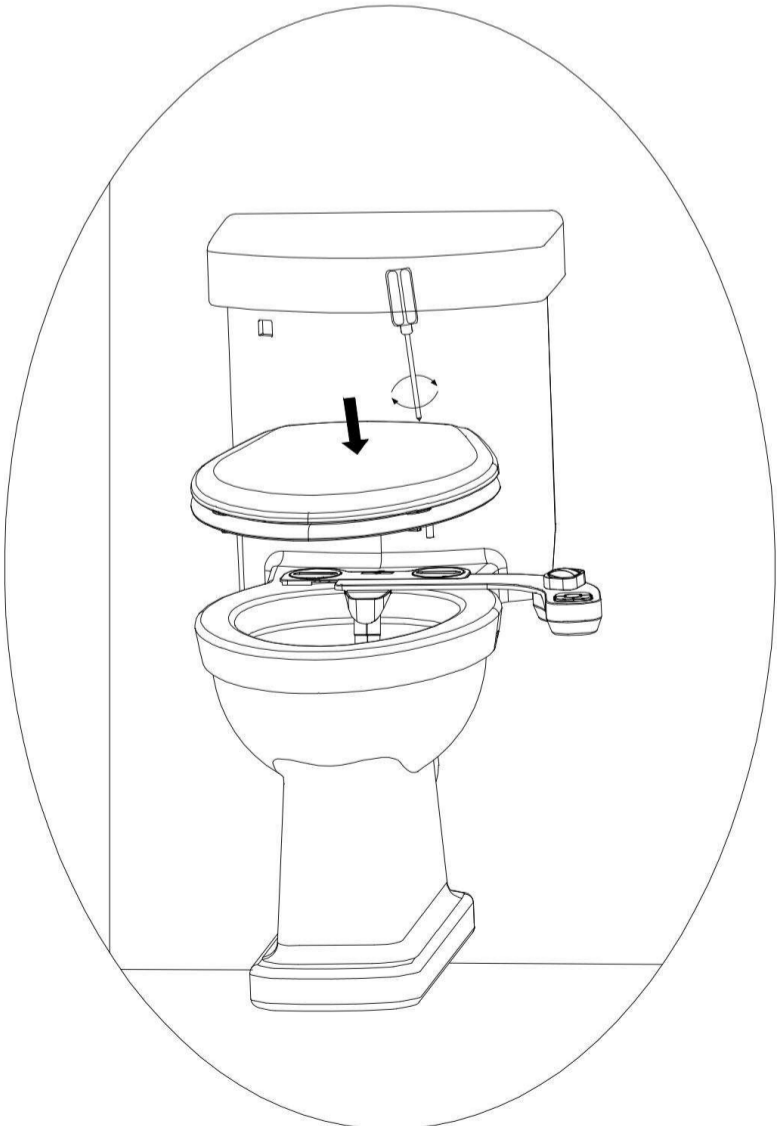

c

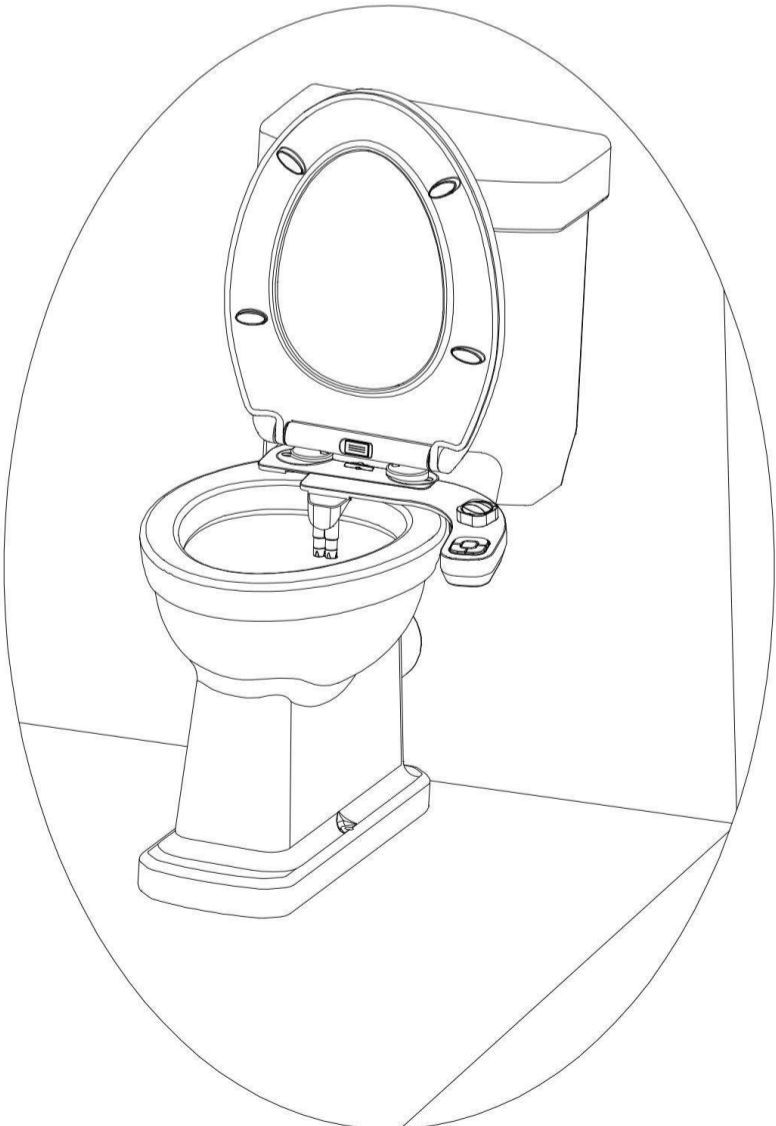

d

Connect Cold Water

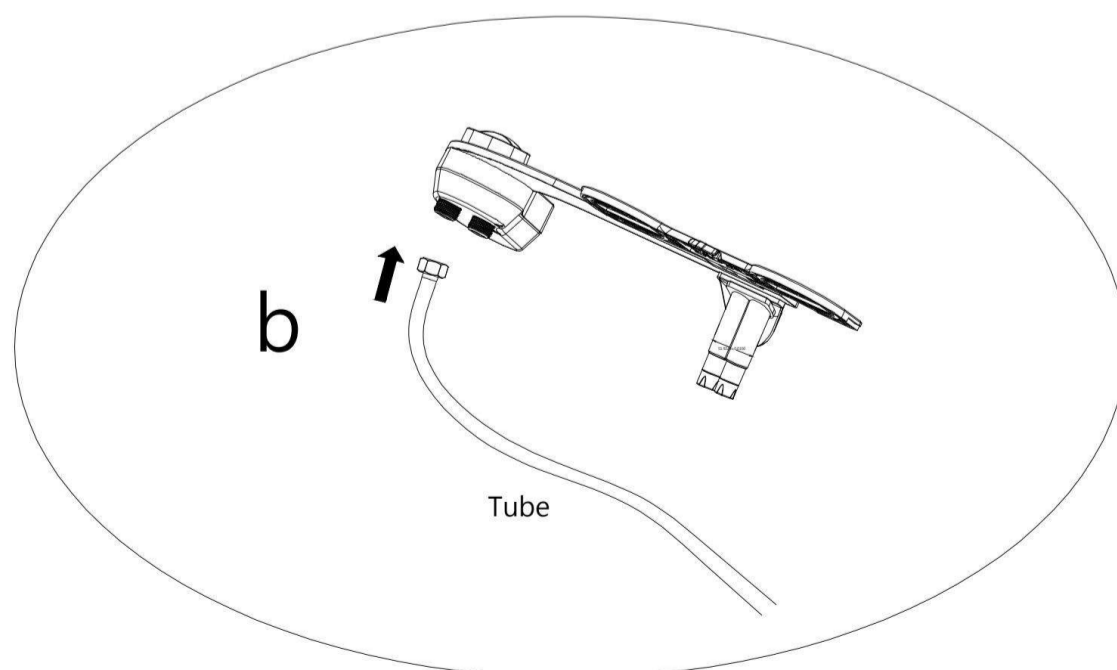
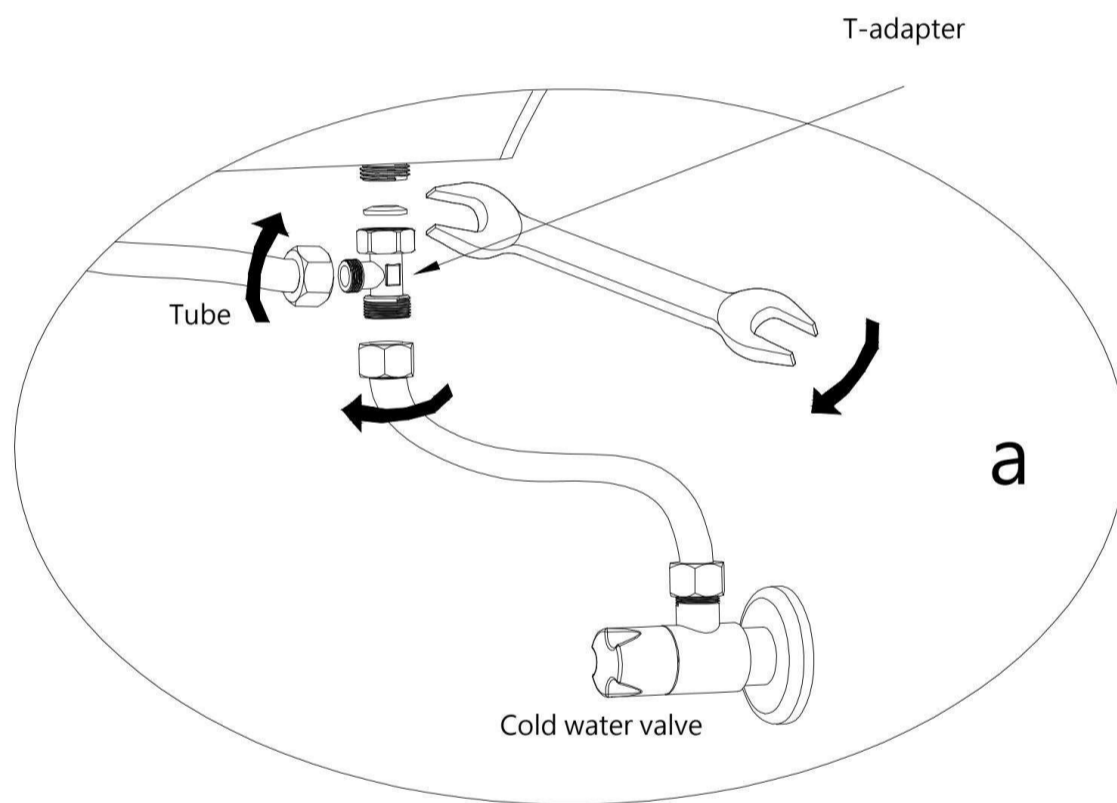
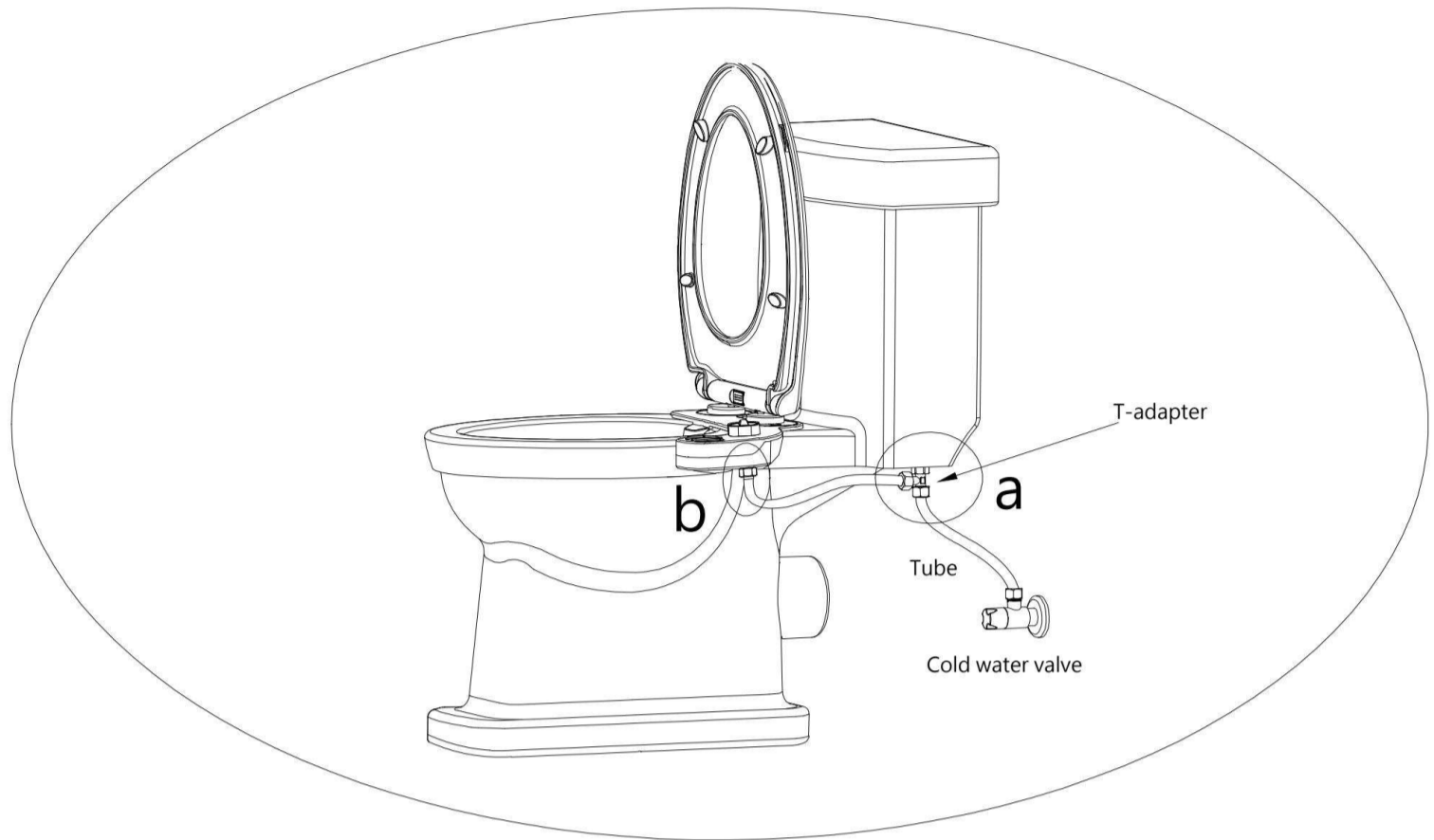

Connect Hot Water

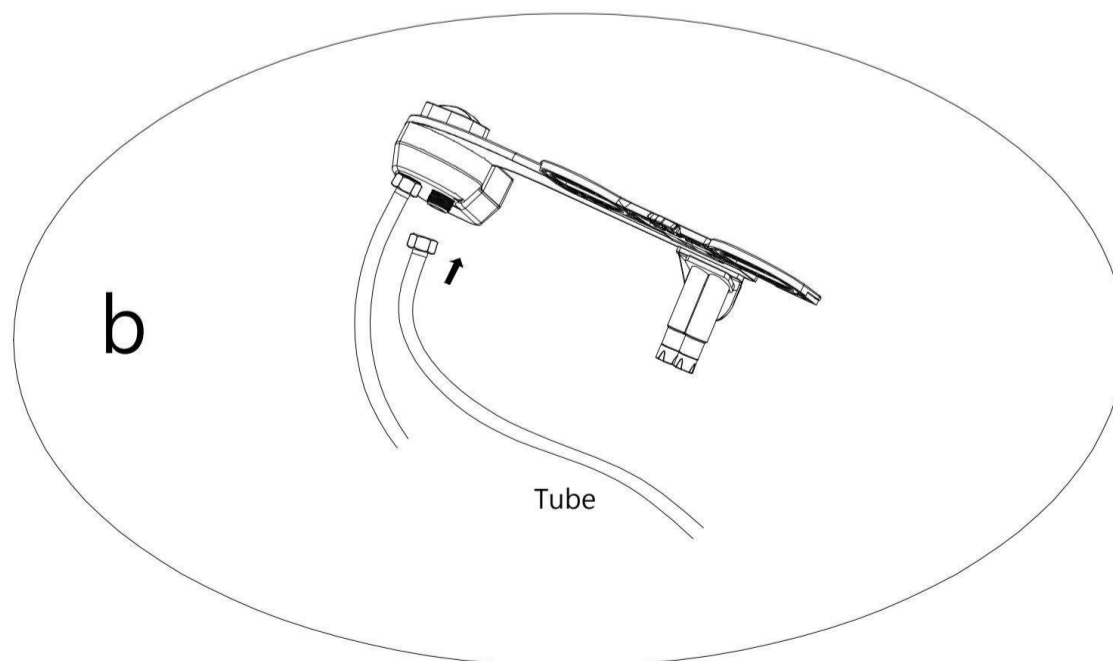
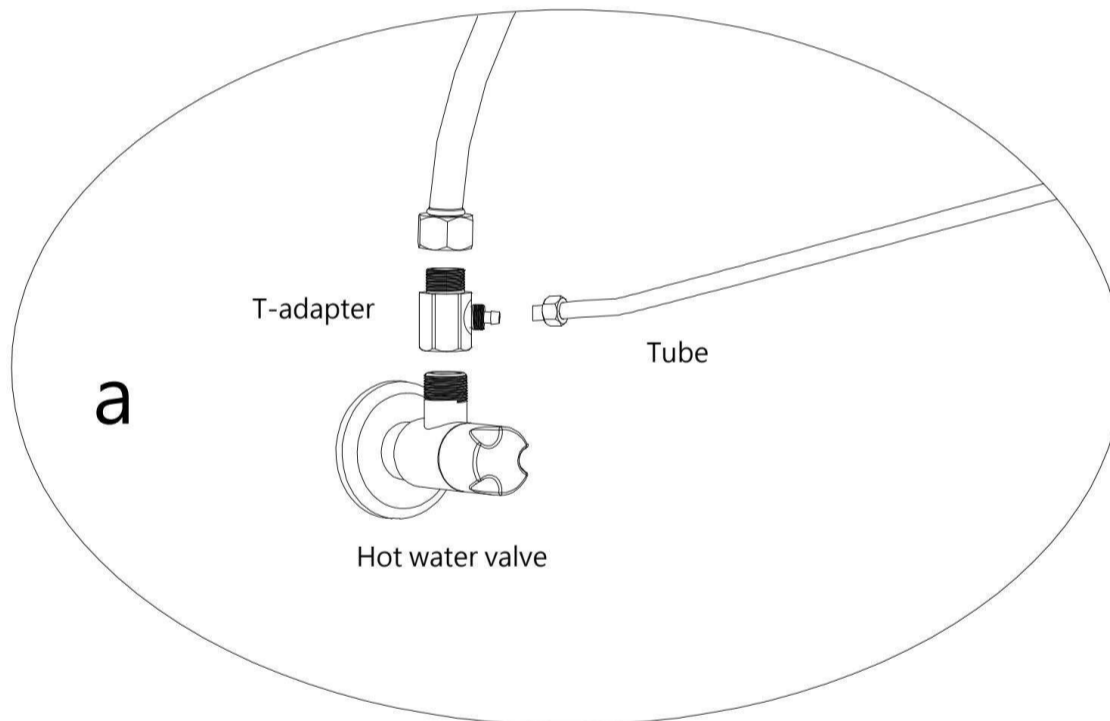
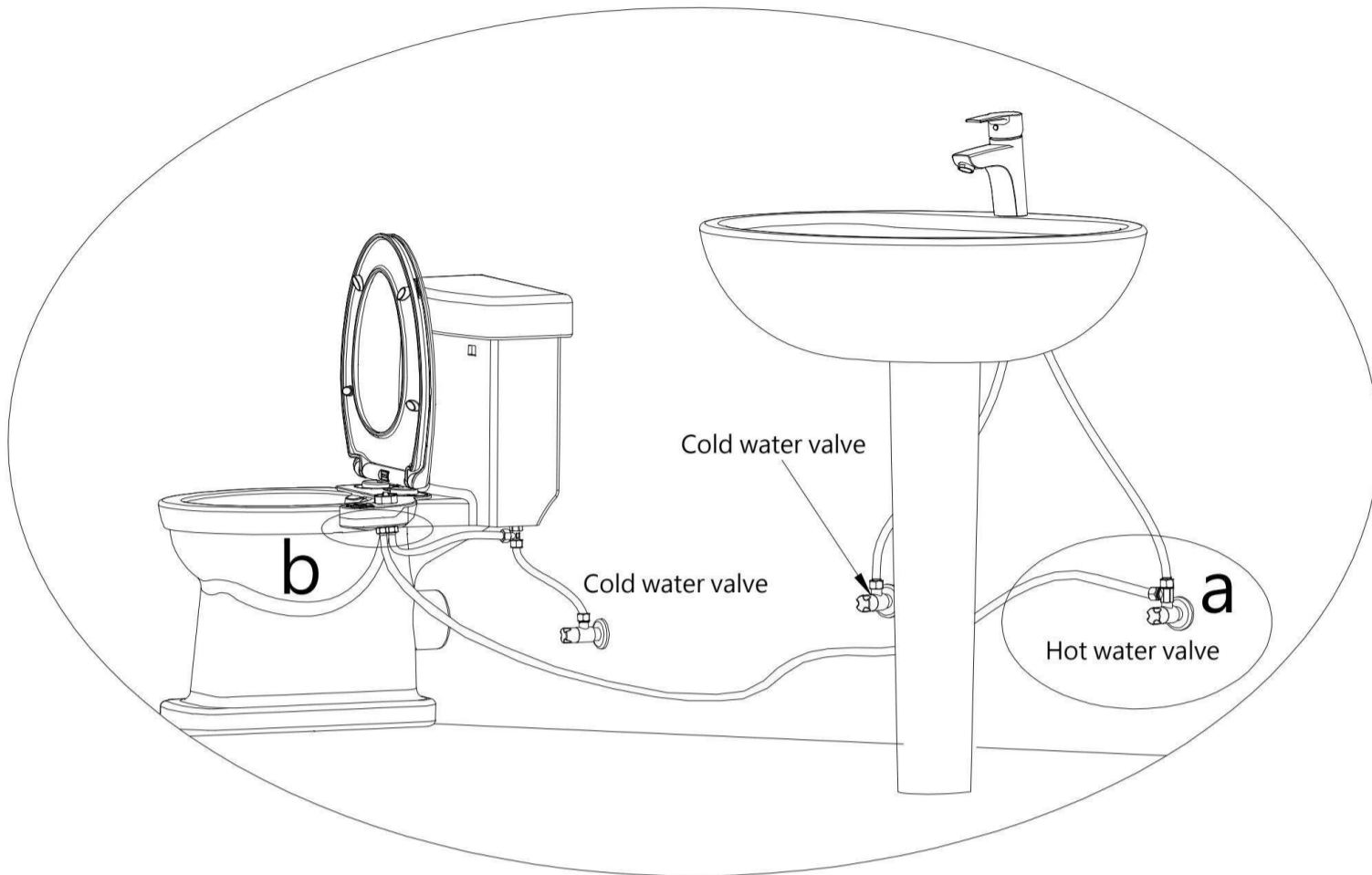

Quick Release

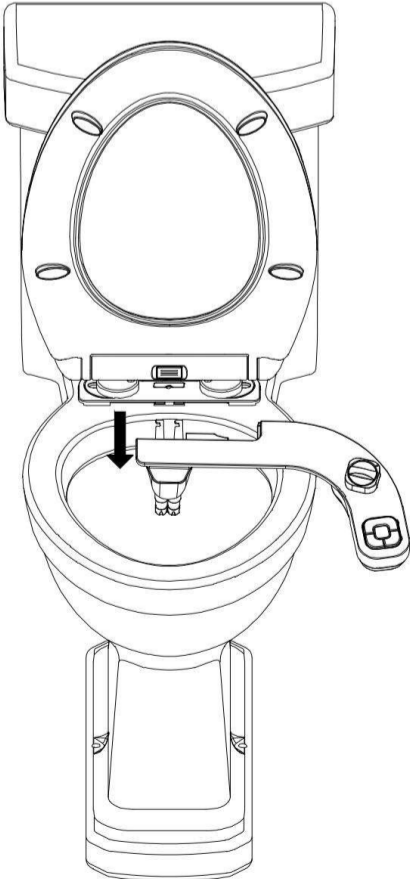
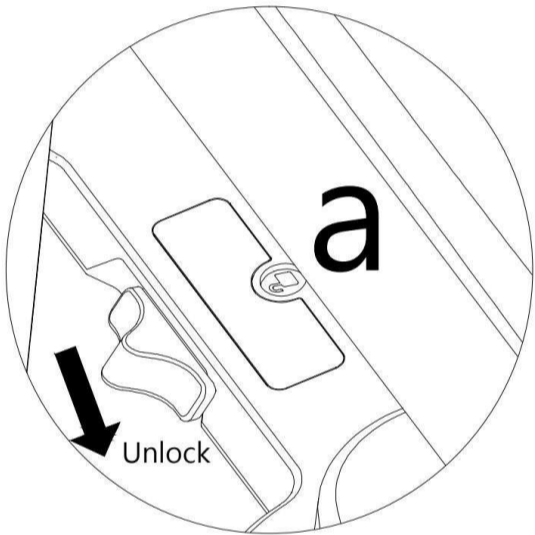
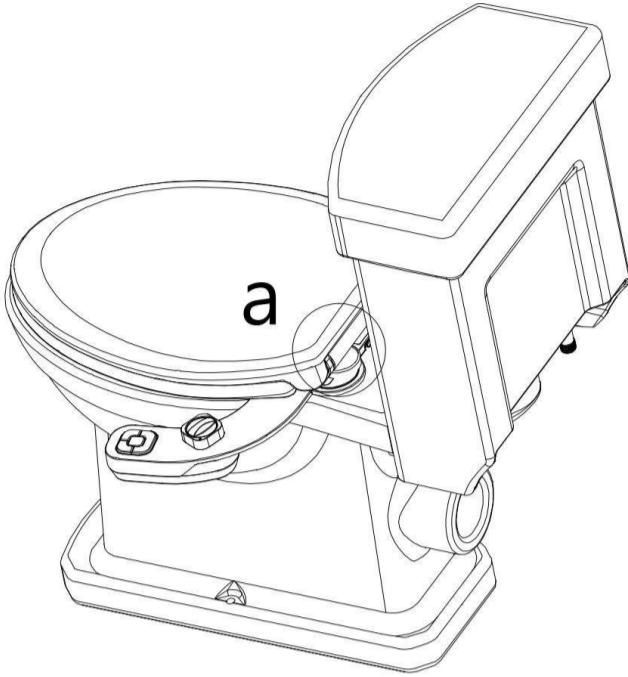

Quick Installation

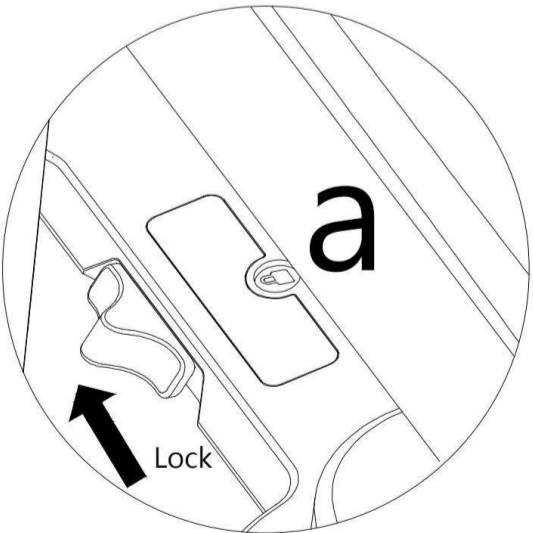
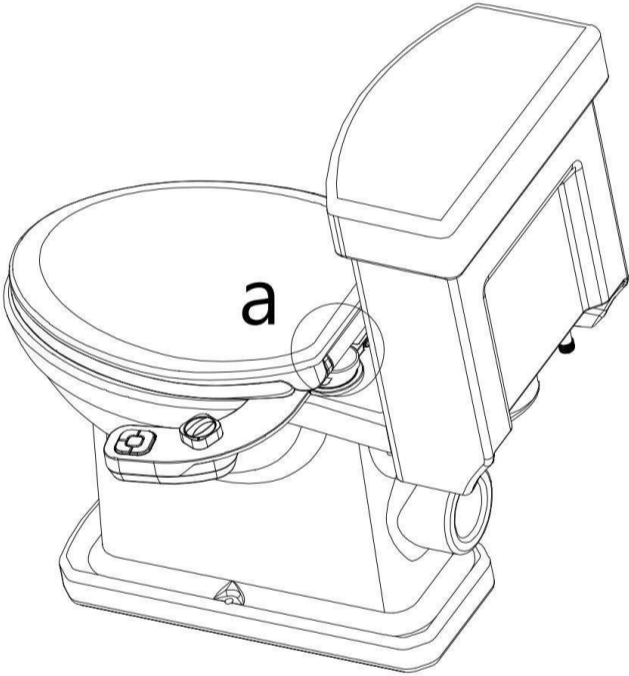
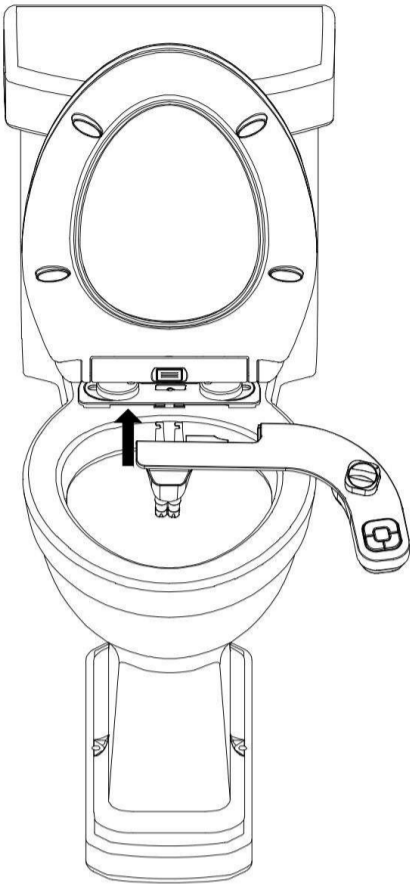

Operating Instructions



1. Select the nozzle function using the button.

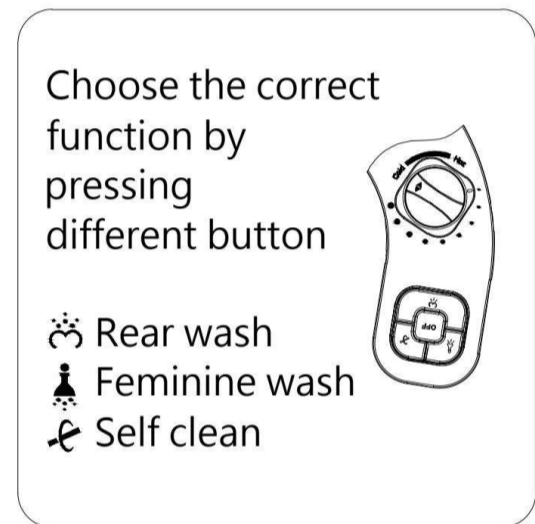
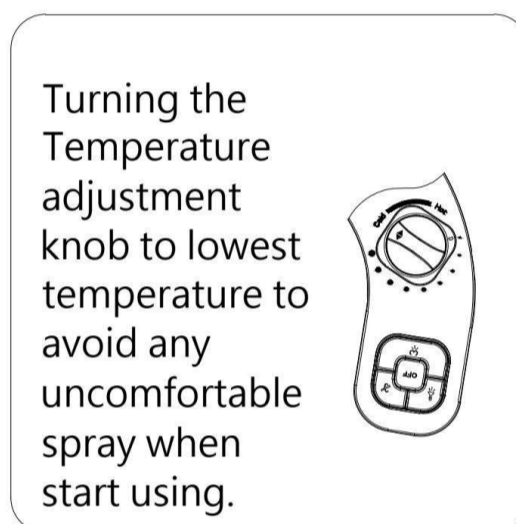
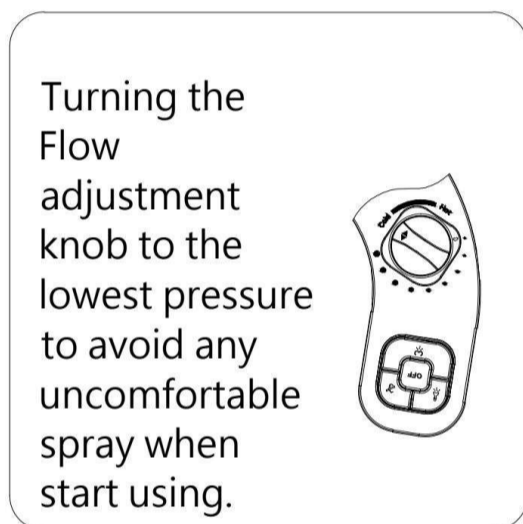

2. Adjust the water flow.

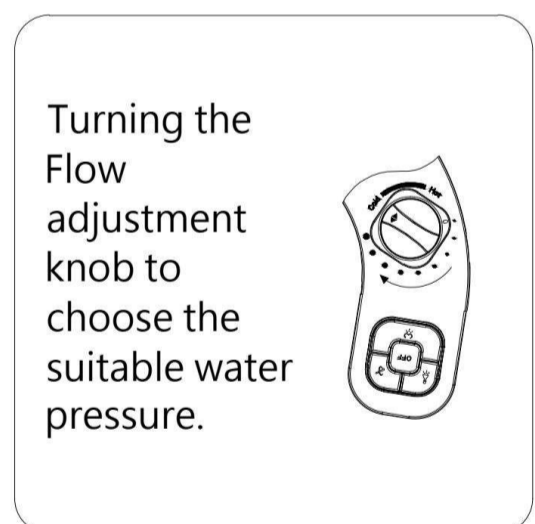
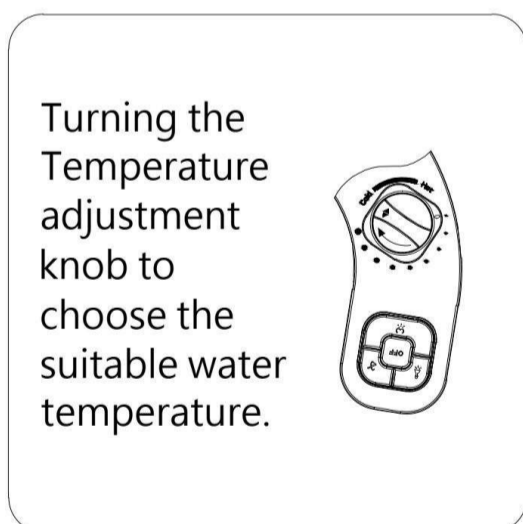

3. Use as long as needed.

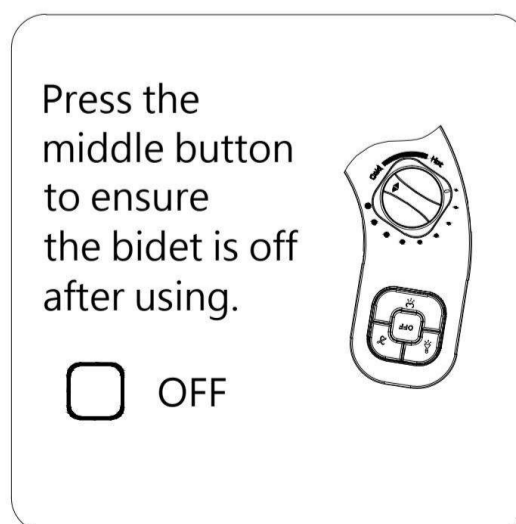

MANUAL DE INSTRUCCIONES

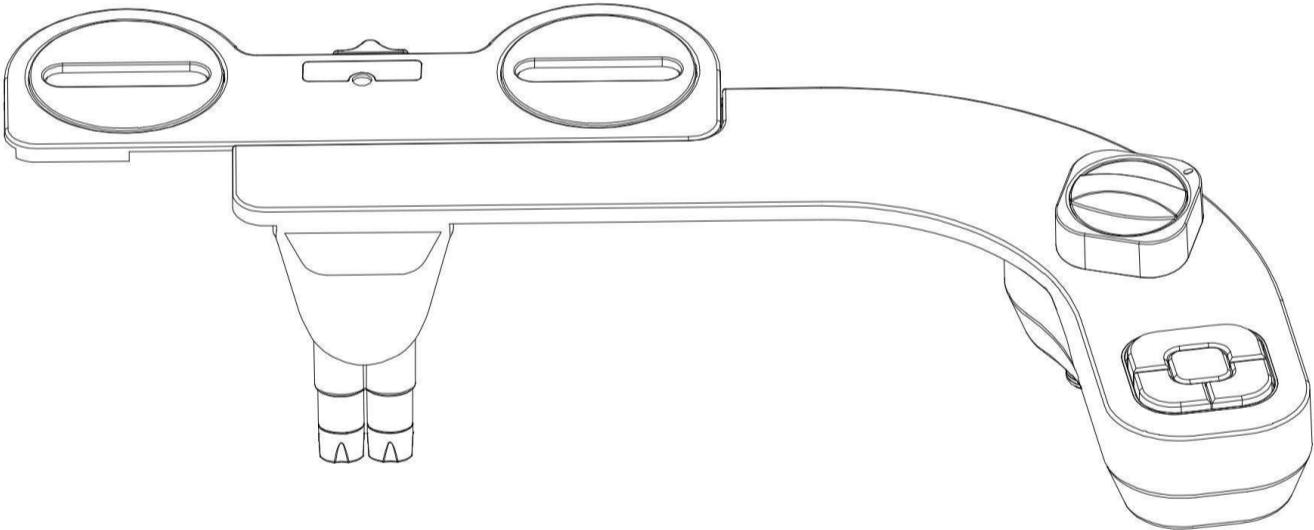

Nombres y funciones de las piezas

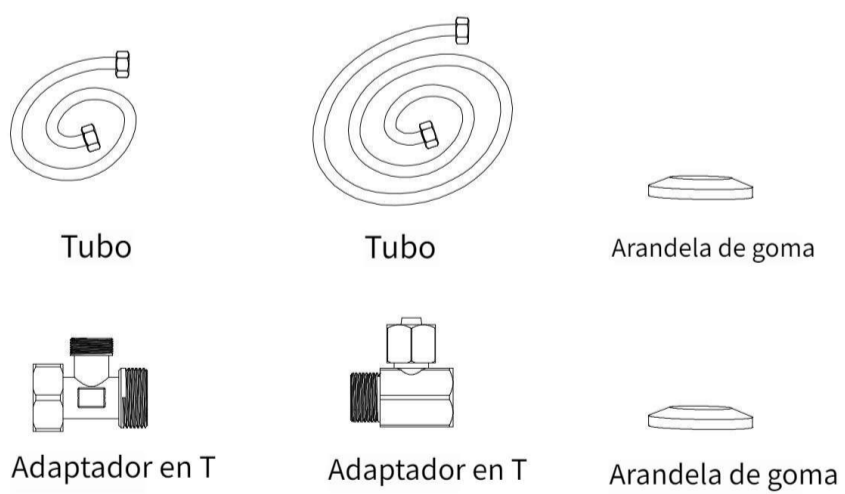
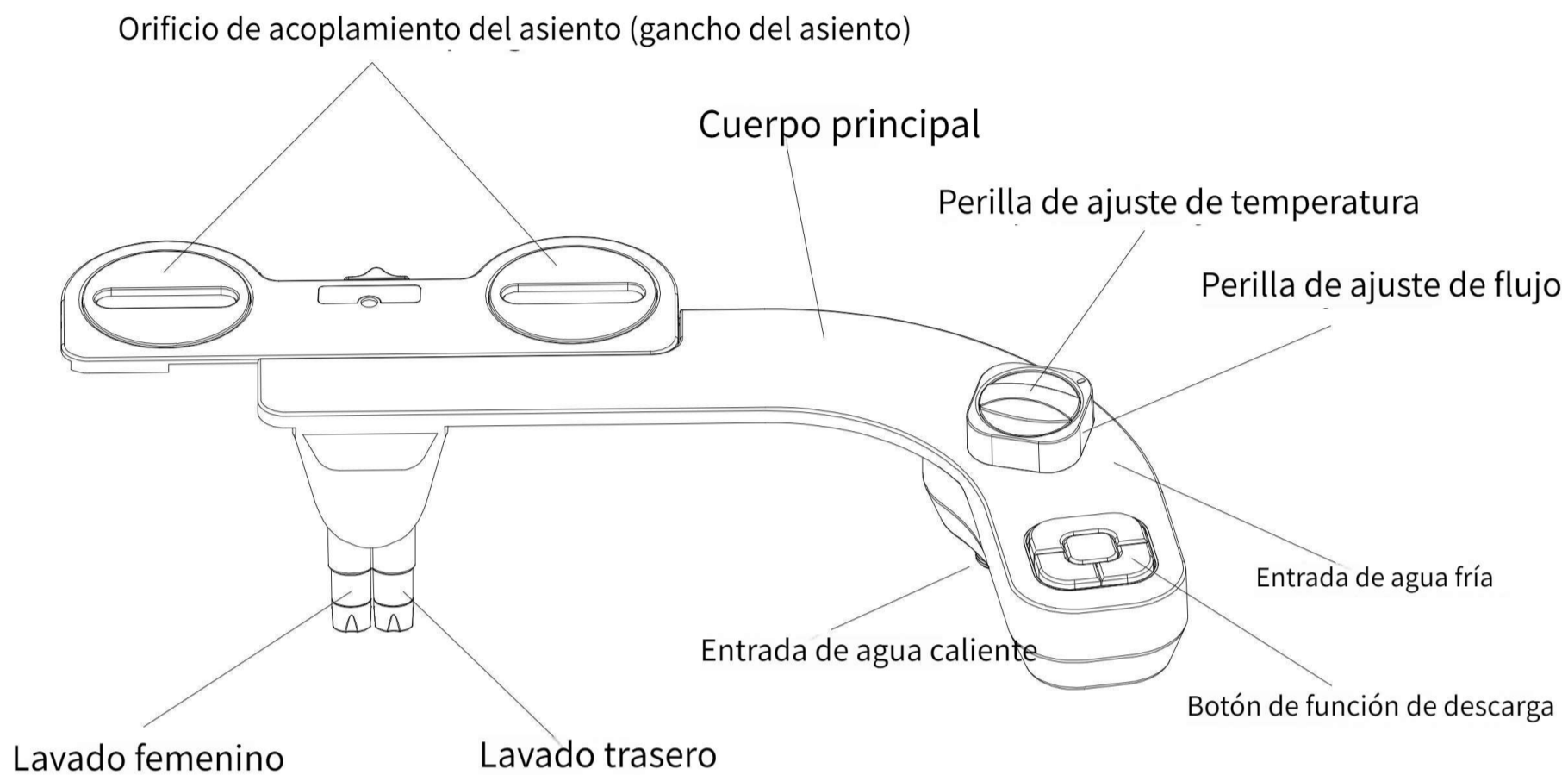

Instalar el bidé

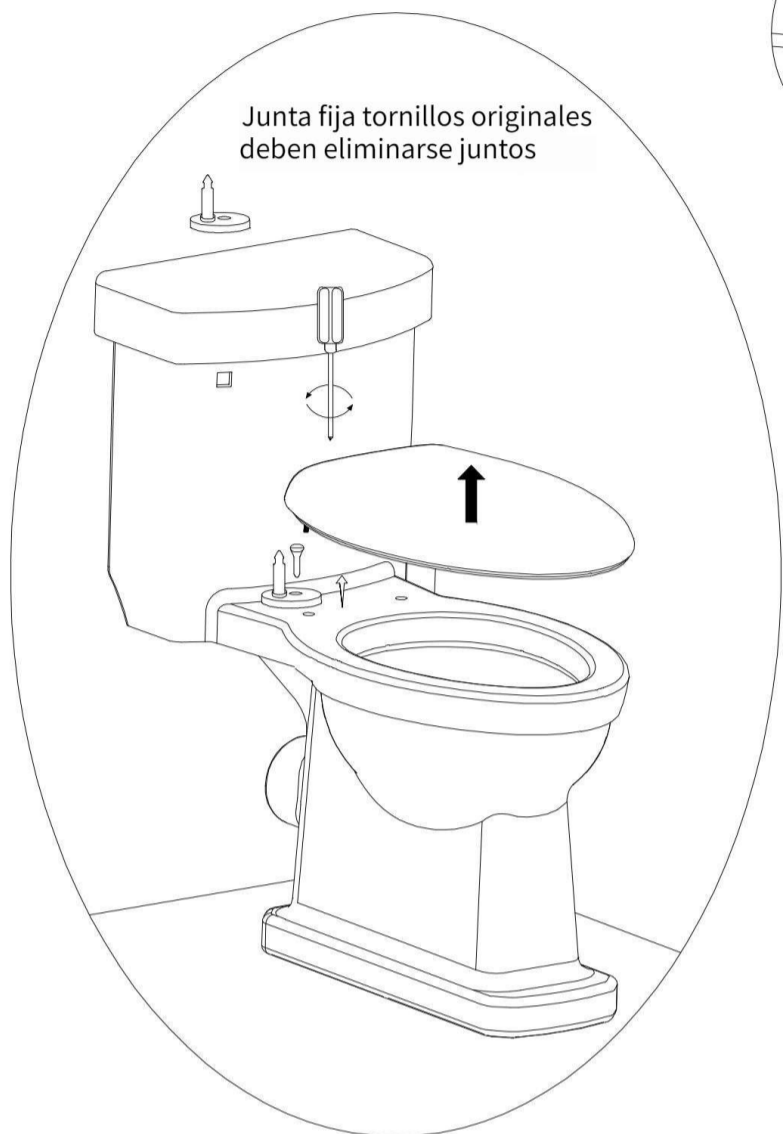

a

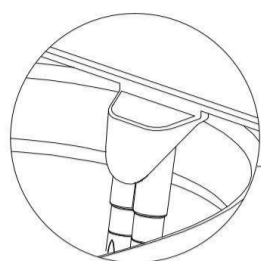

Ajustar la boquilla posición y trate de hazlo cerca del borde del inodoro.

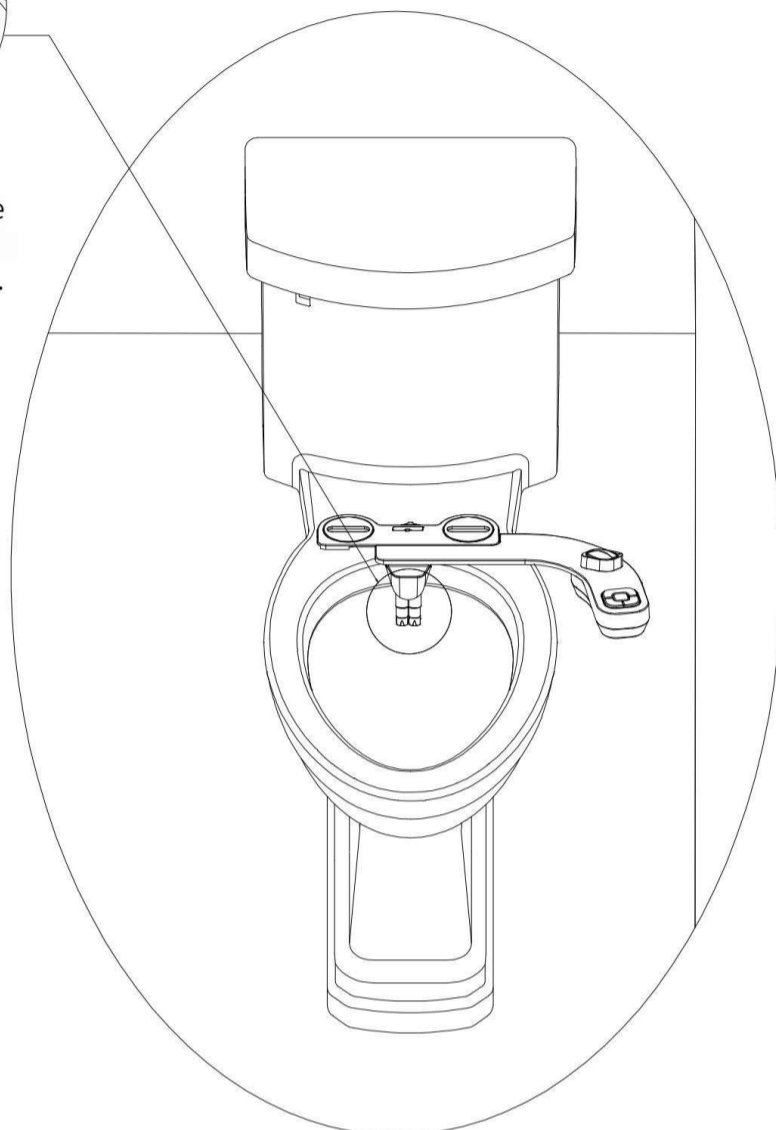

b

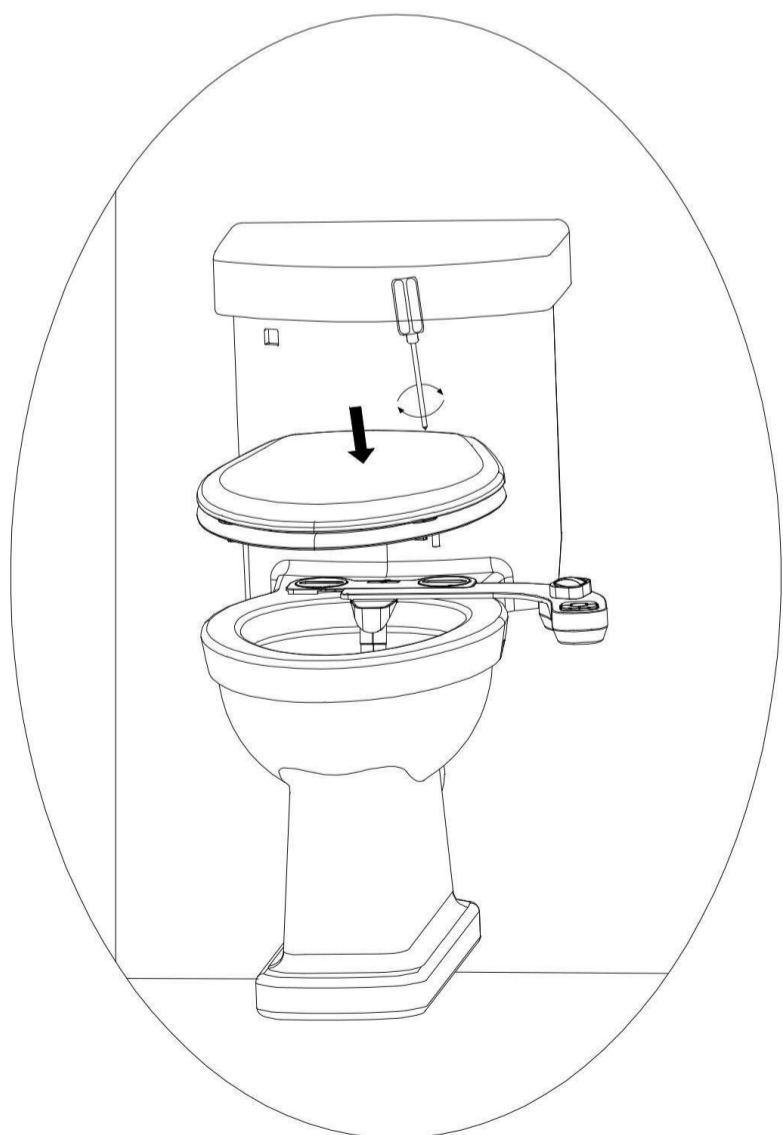

c



d

Conectar agua fría

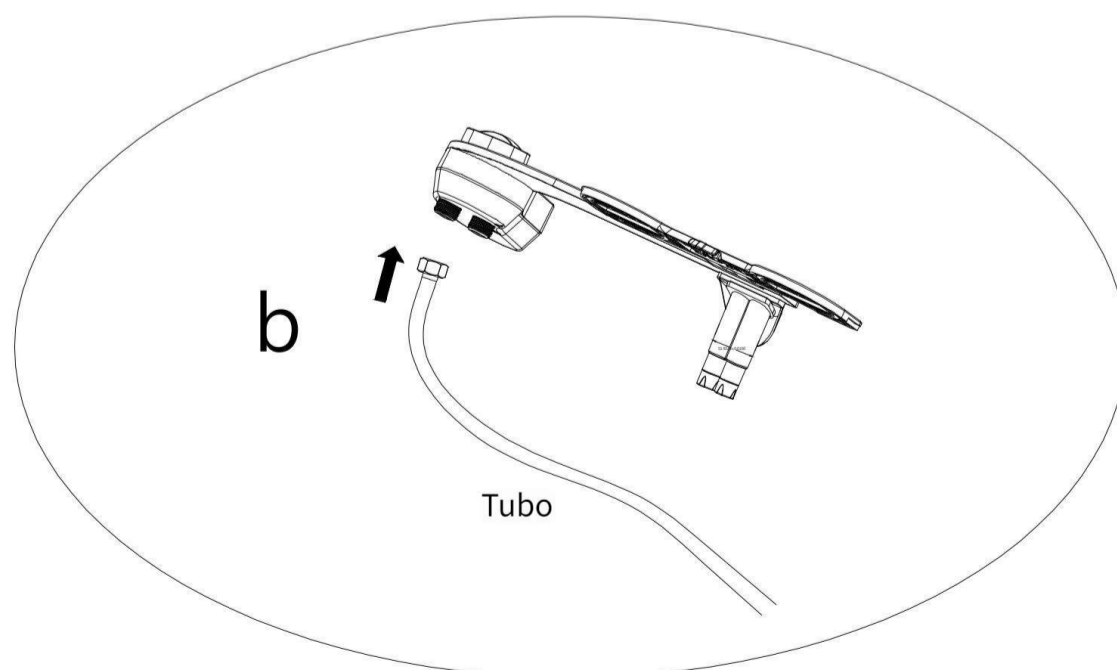
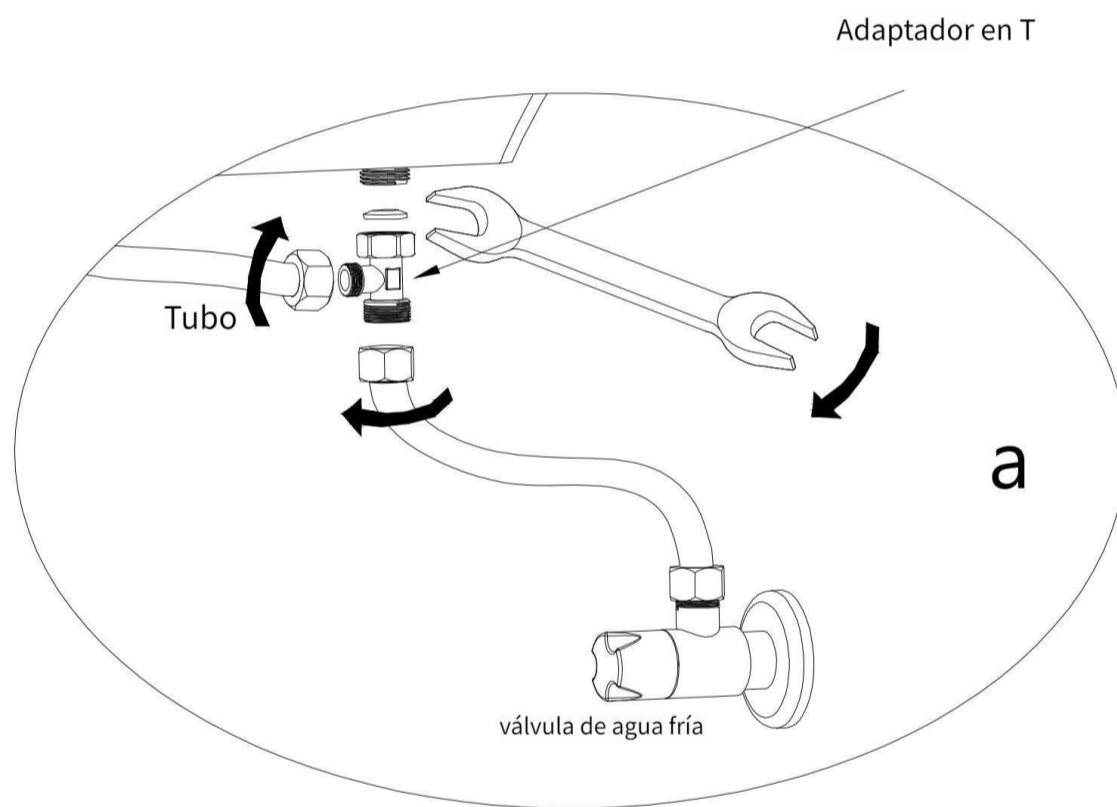
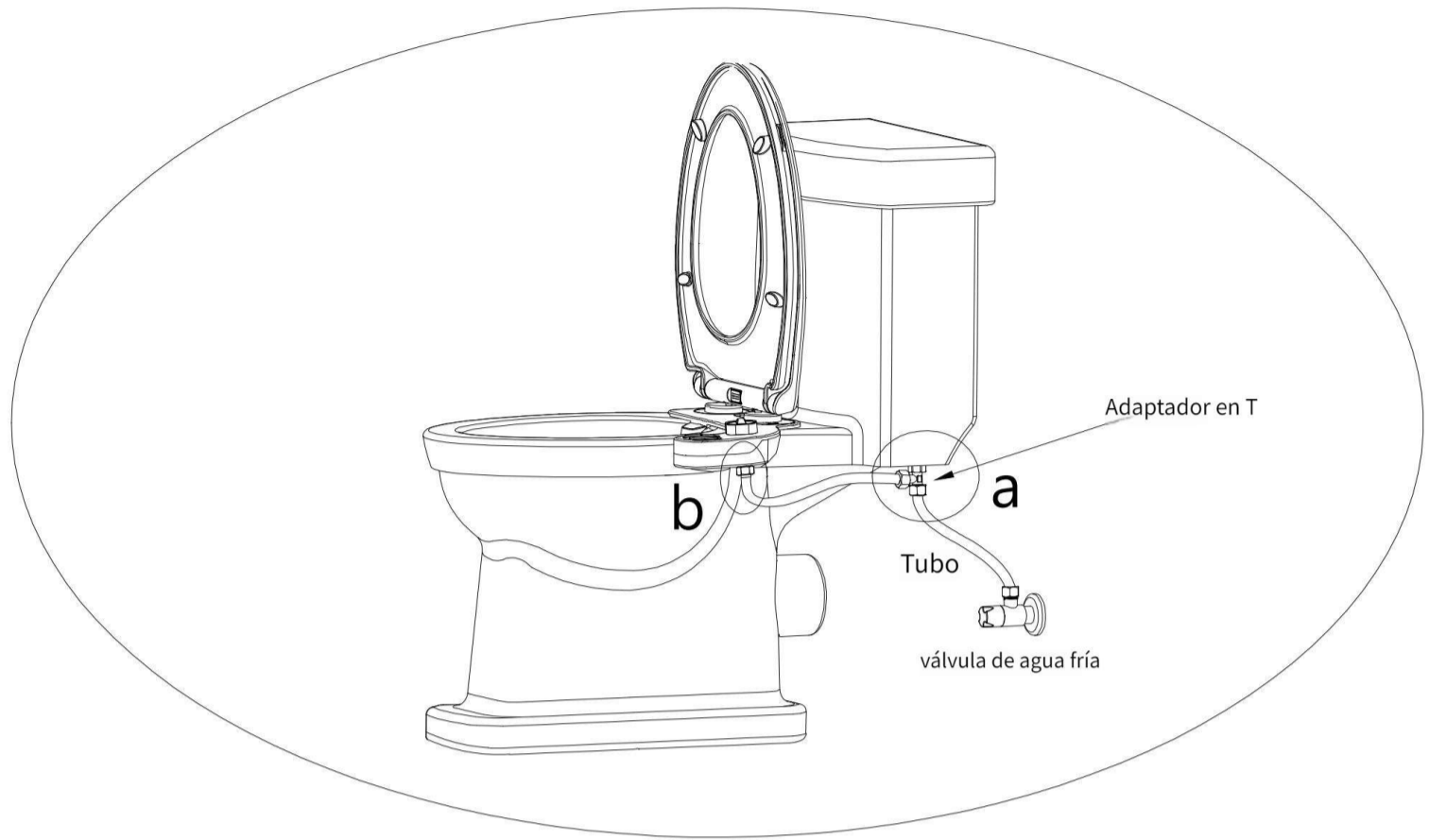

Conectar agua caliente

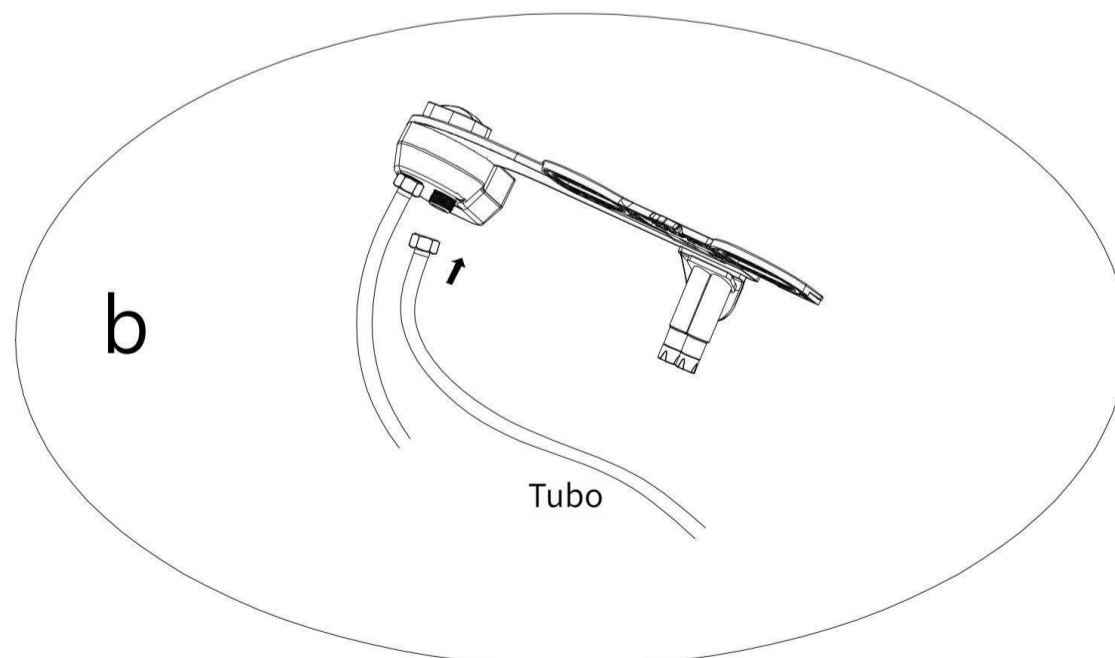
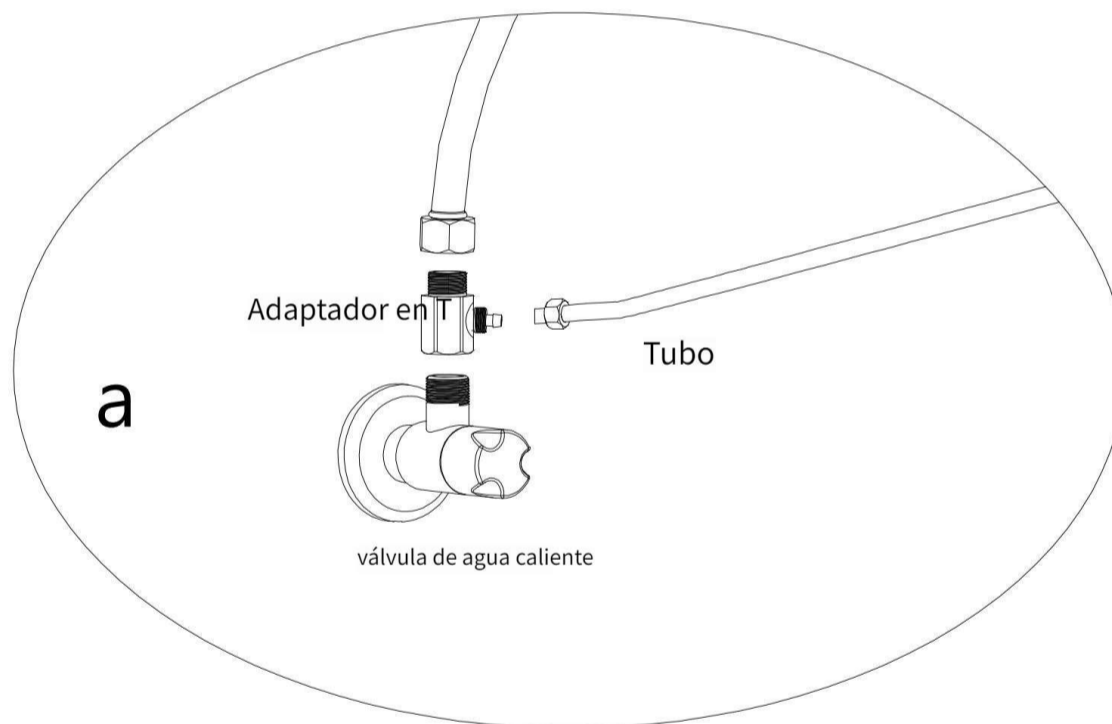
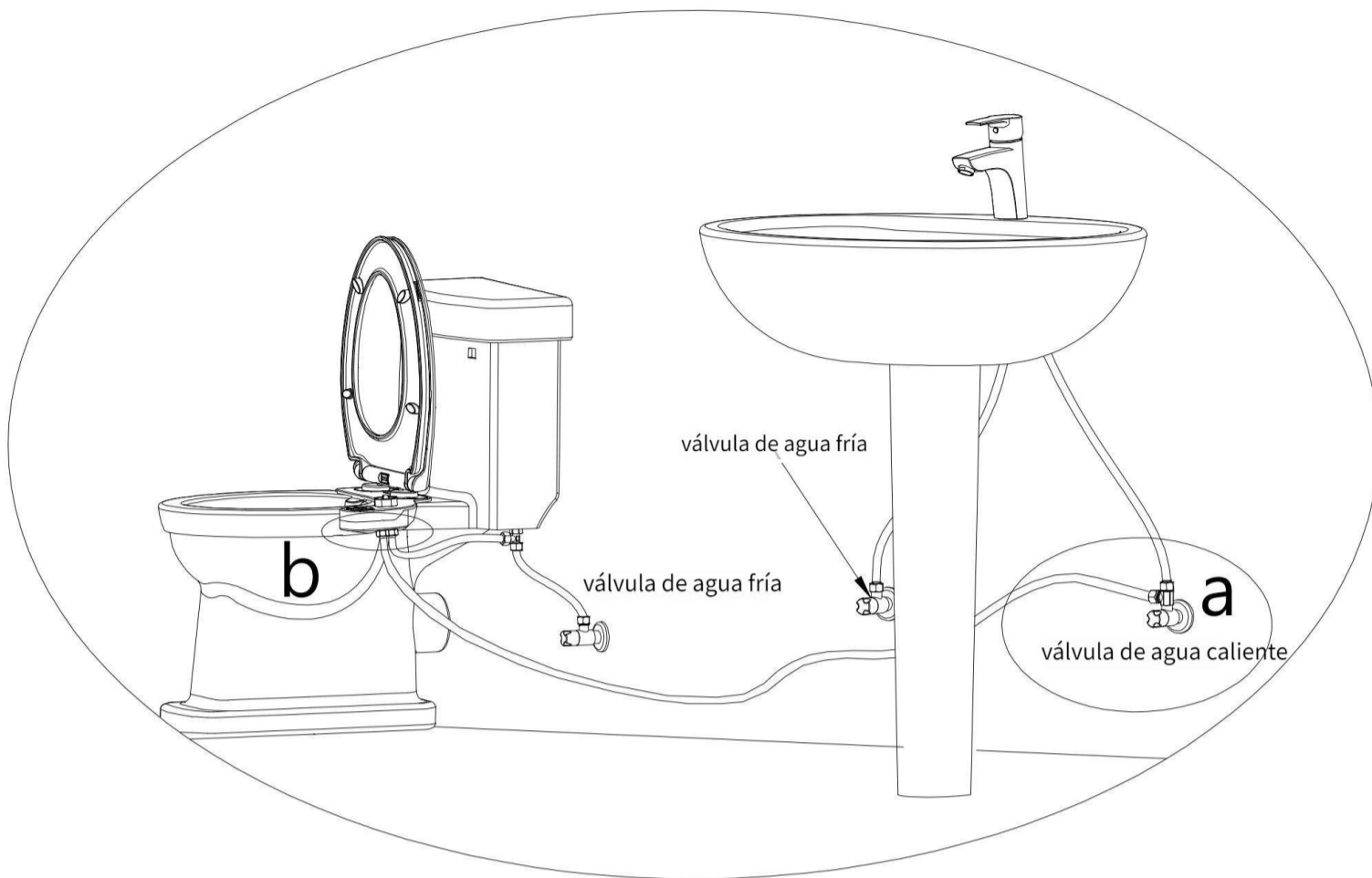

Liberación rápida

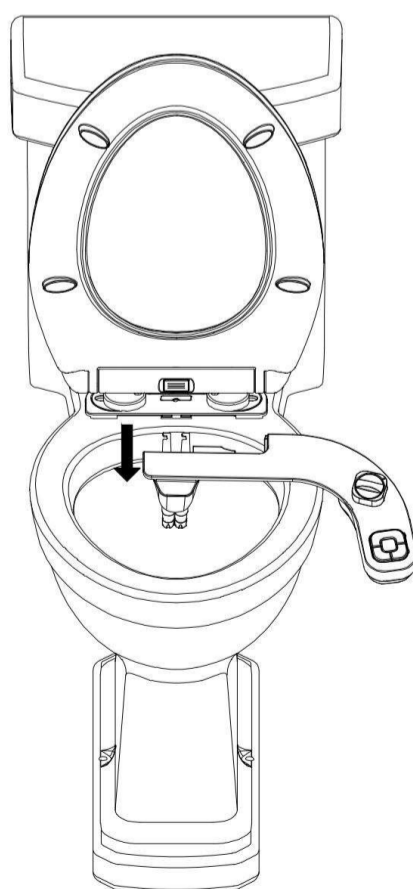
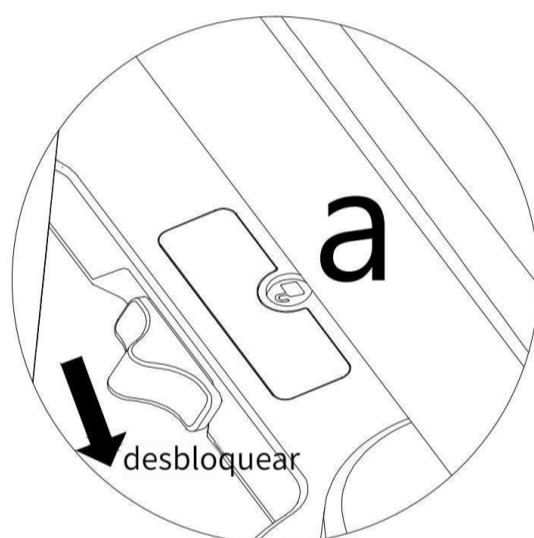
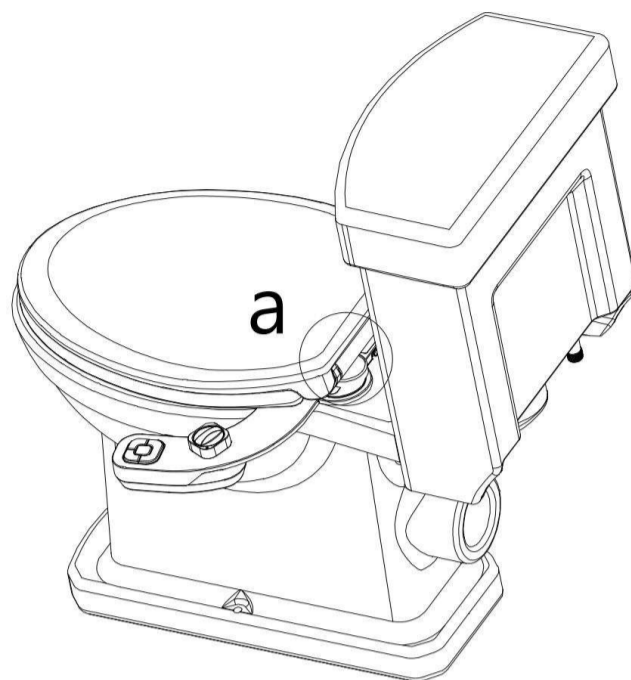

Instalación rápida

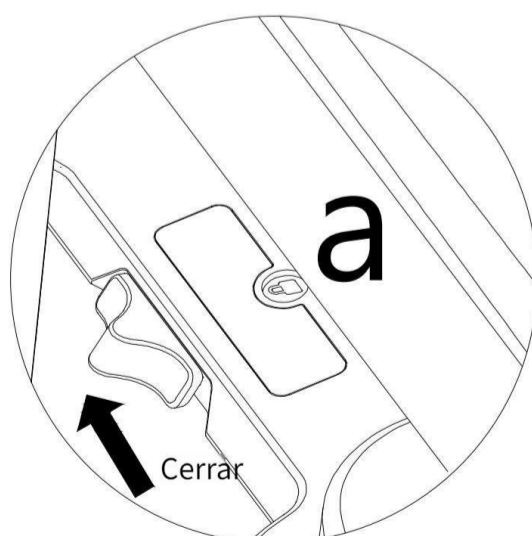
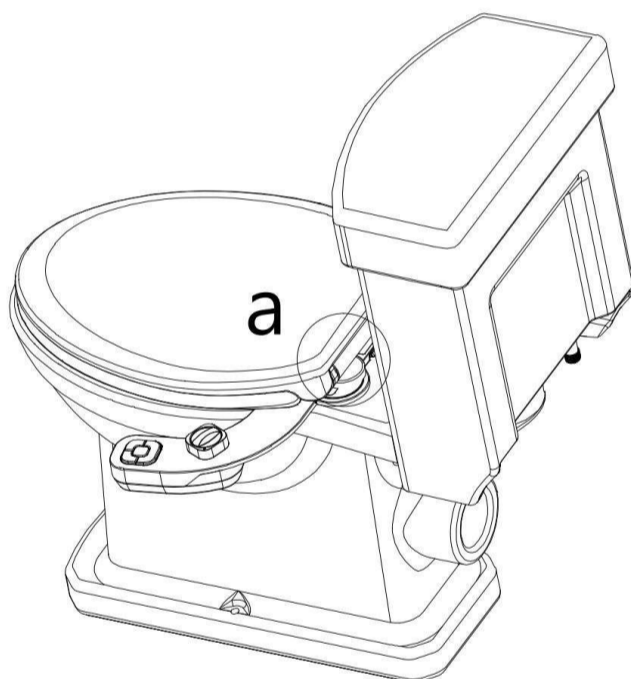
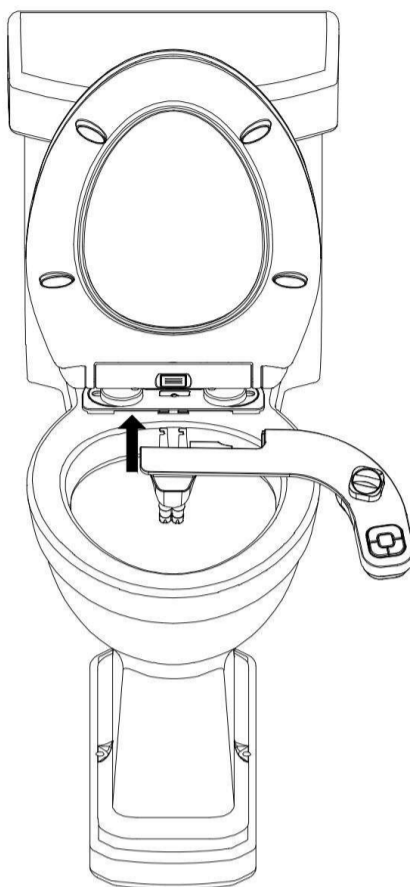

Operando Instrucciones

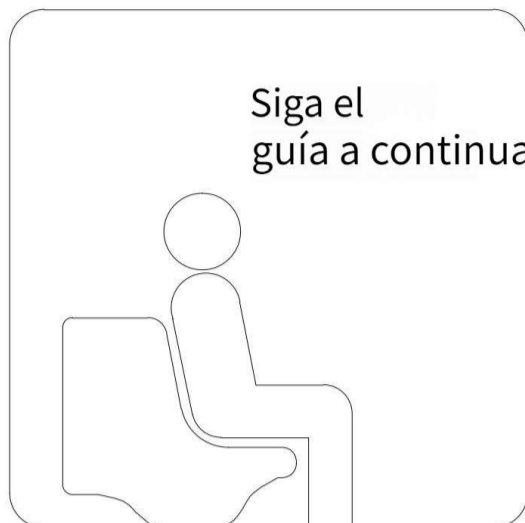

1. Seleccione la función de la boquilla usando el botón.

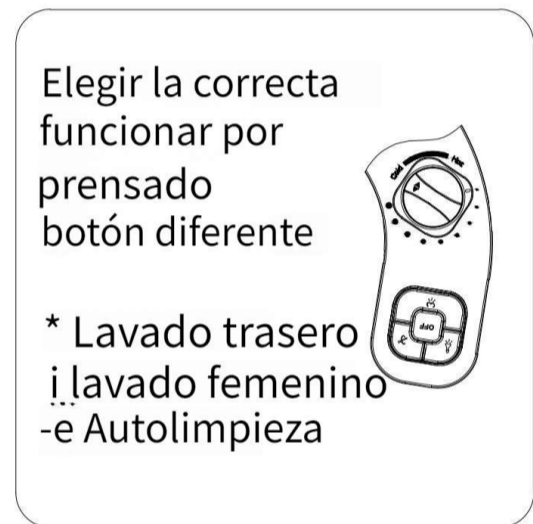
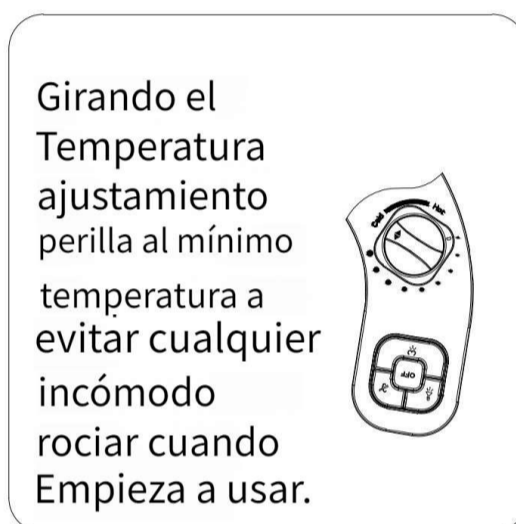
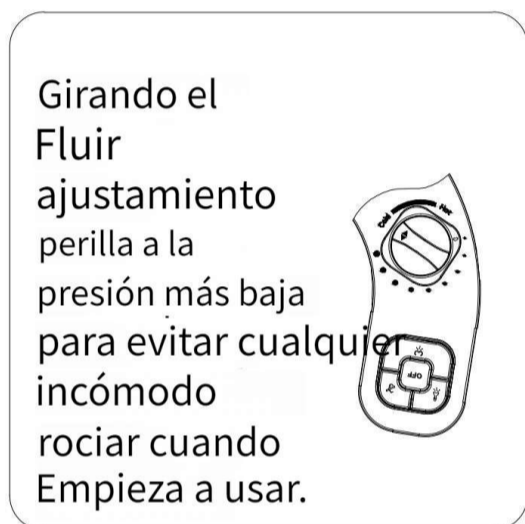

2. Ajuste el flujo de agua.

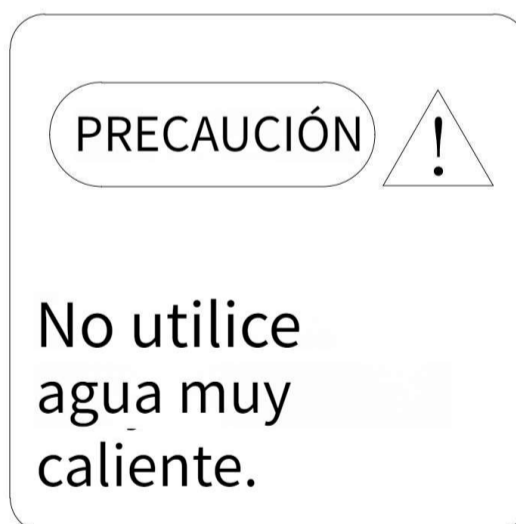

3. Úselo todo el tiempo que sea necesario.

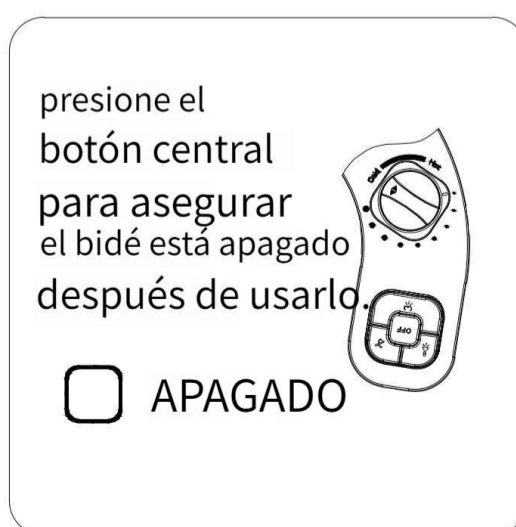

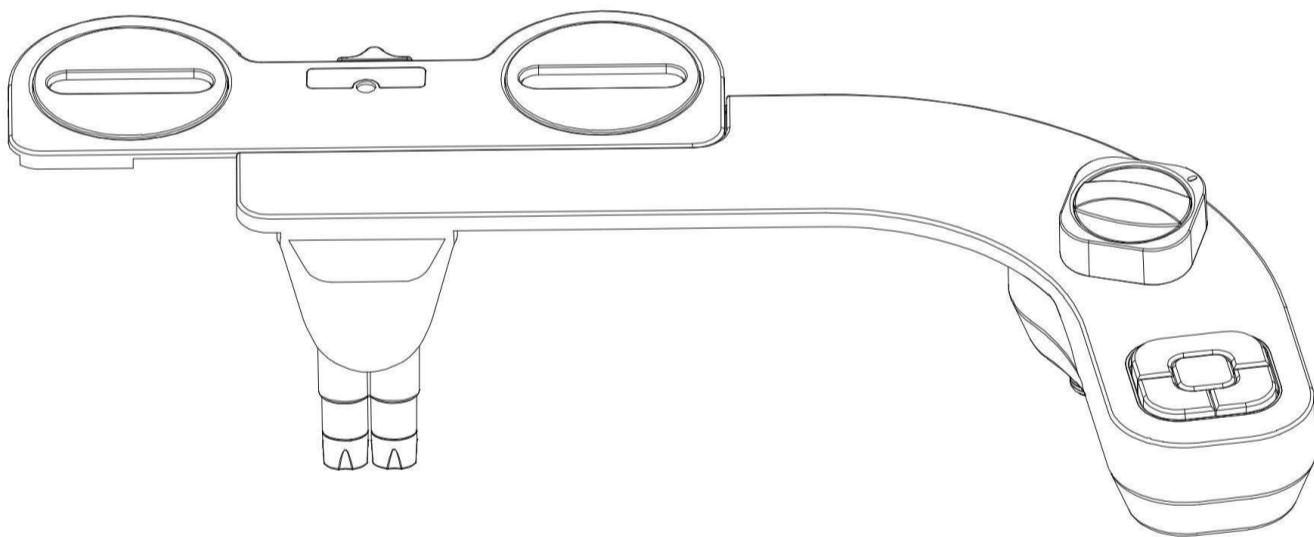

BEDIENUNGSANLEITUNG

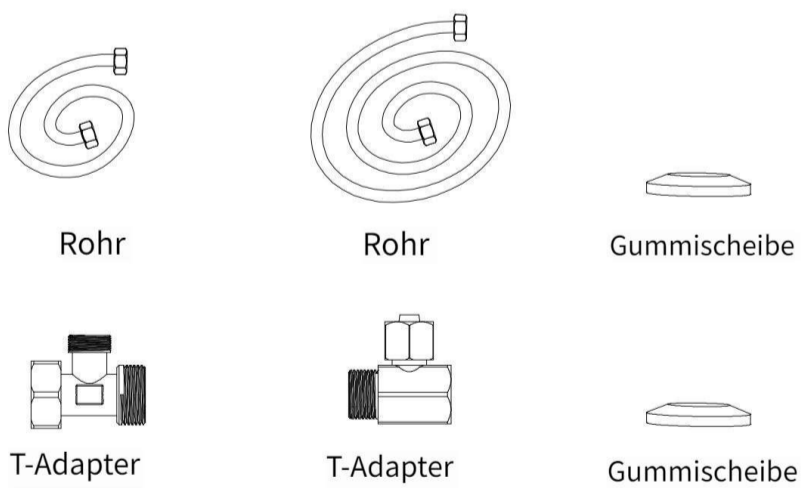
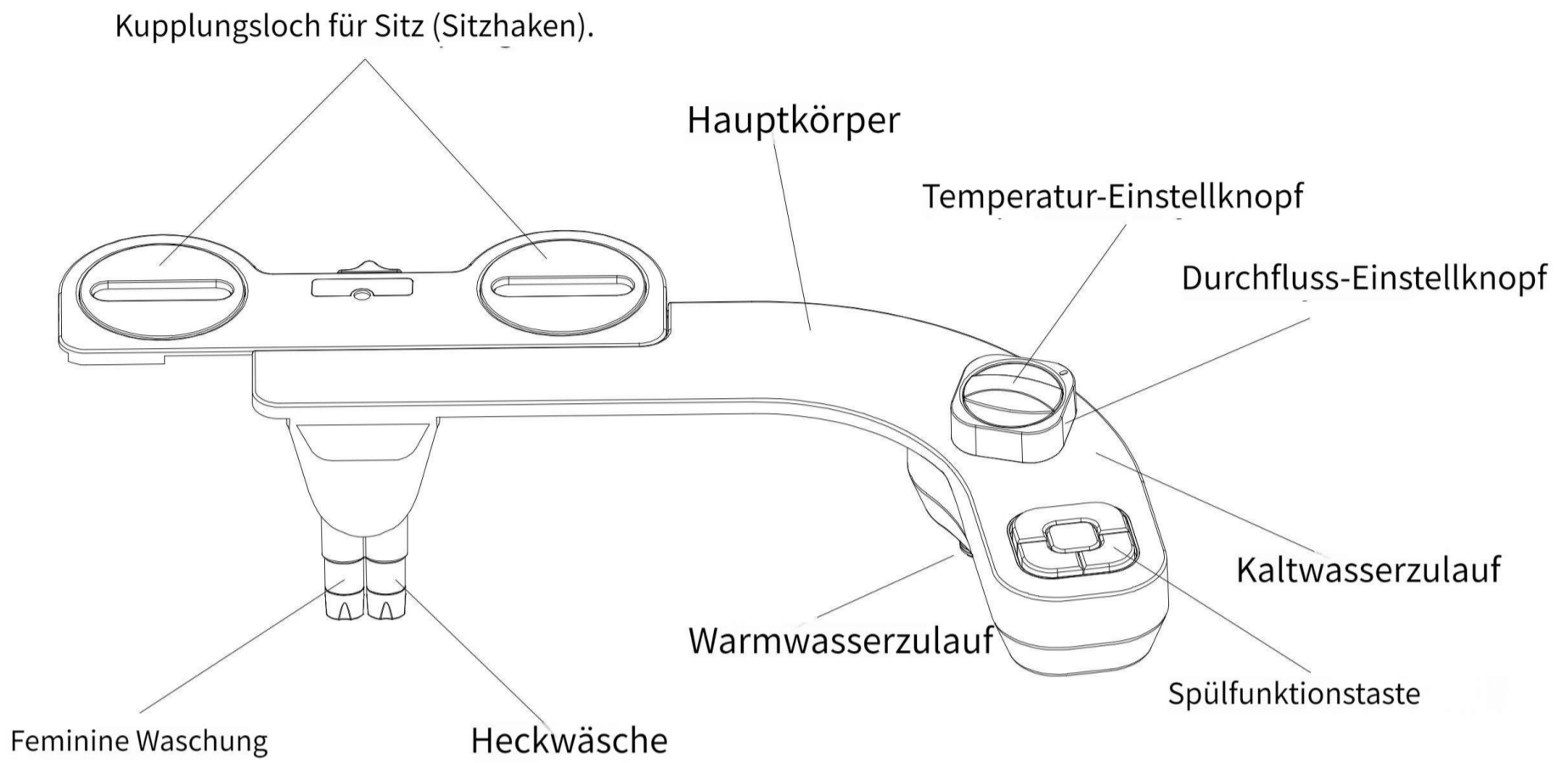

Namen und Funktionen von Teilen



Installationswerkzeuge benötigt	
	
Schlüssel	Schraubendreher

Installieren Sie das Bidet

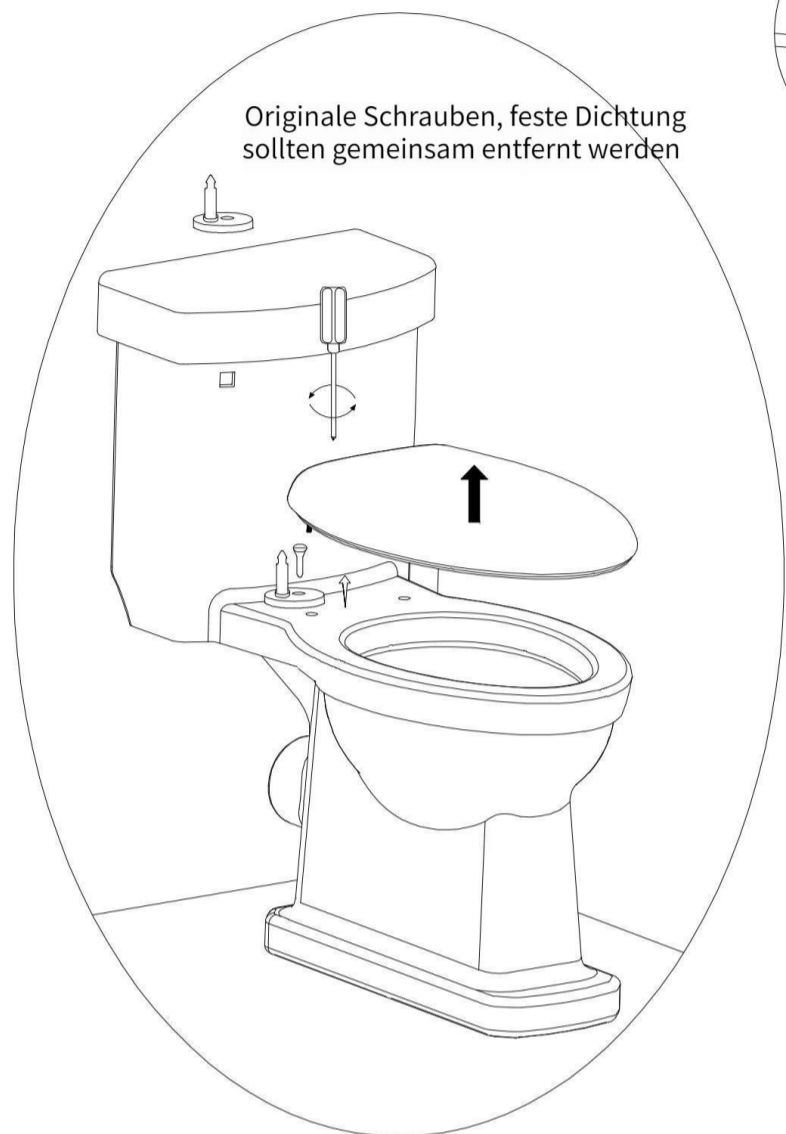

a

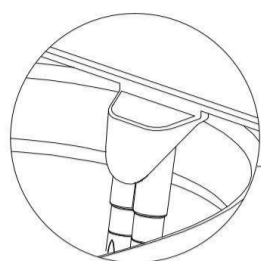

Passen Sie die Düse an positionieren und versuchen. Machen Sie es in die Nähe des Rand der Toilette.

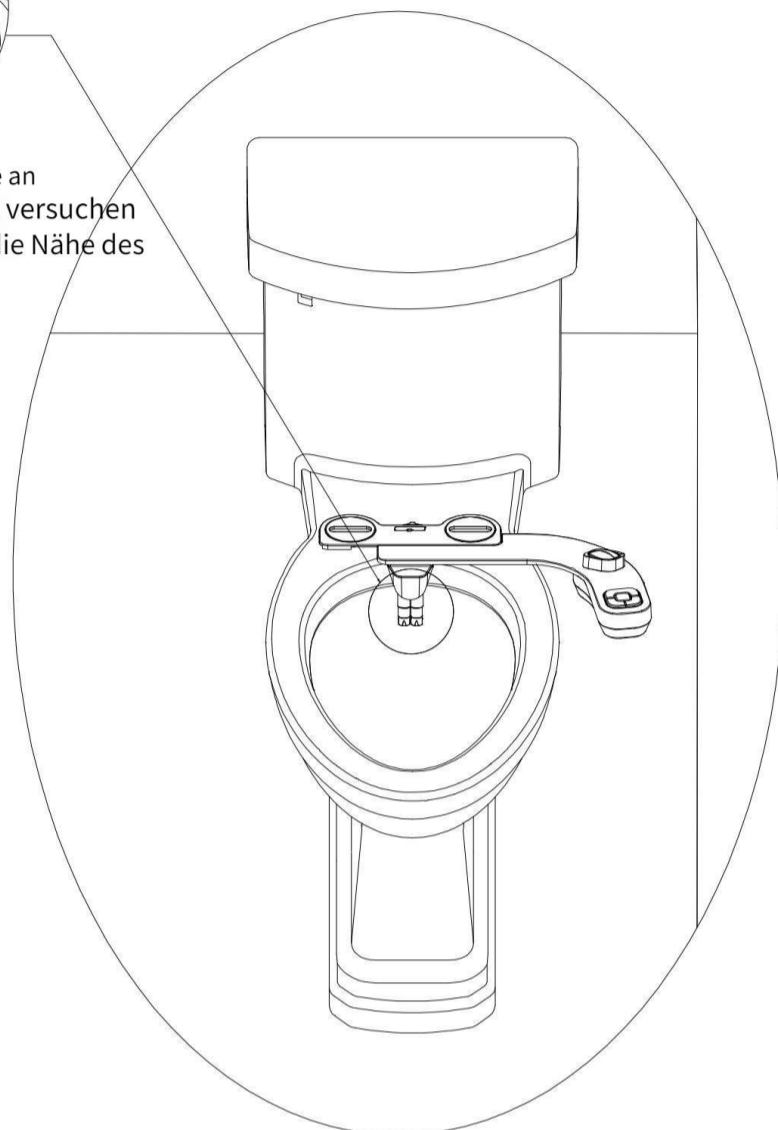

b

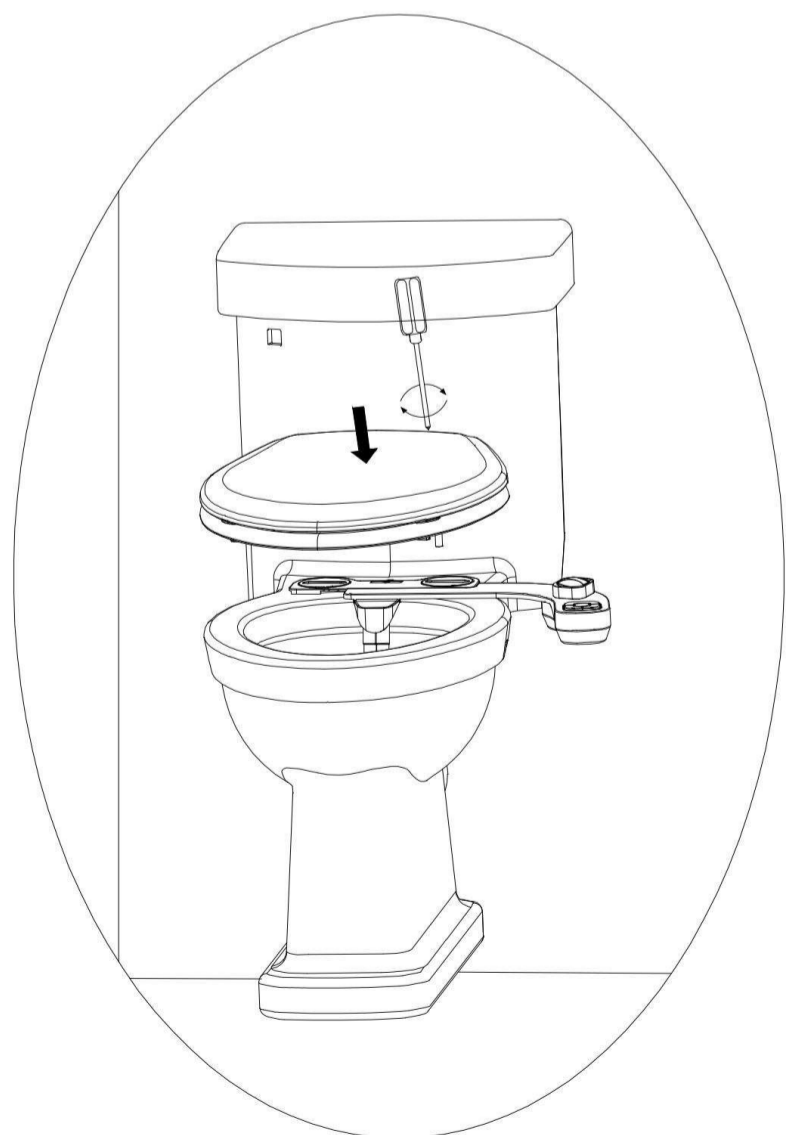

c

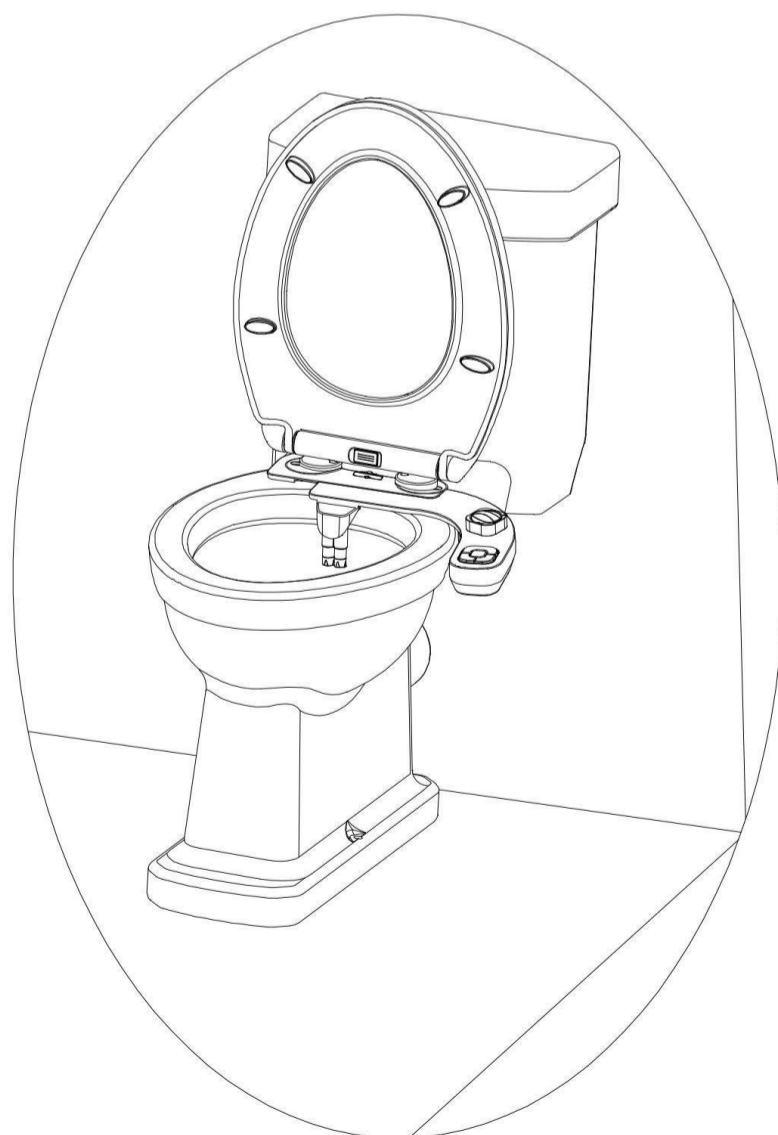

d

Kaltes Wasser anschließen

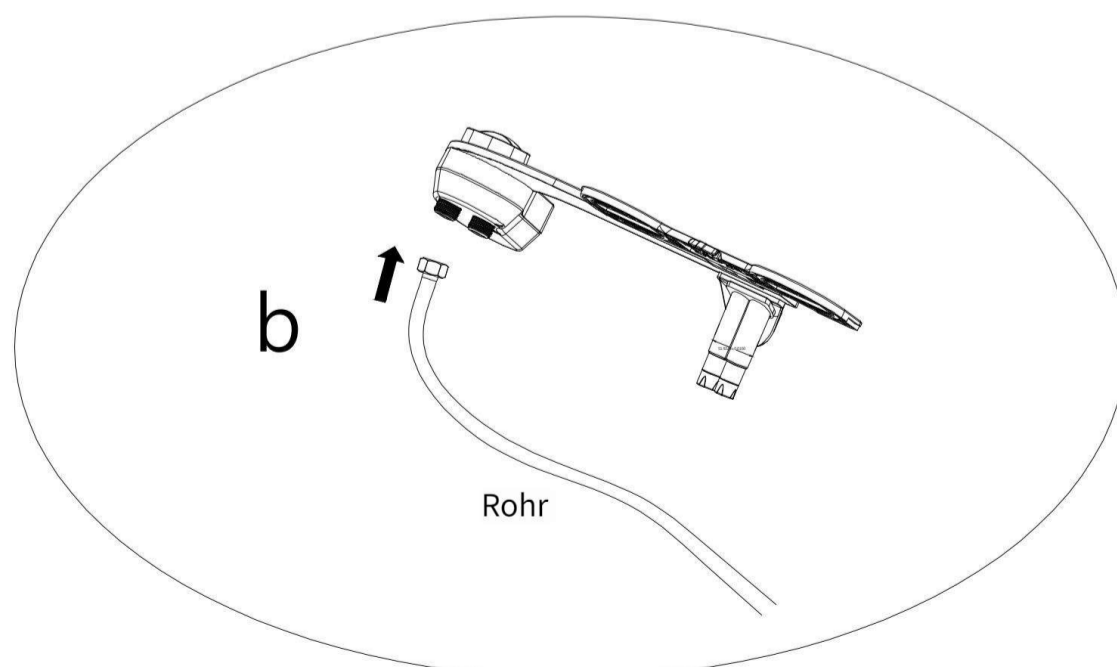
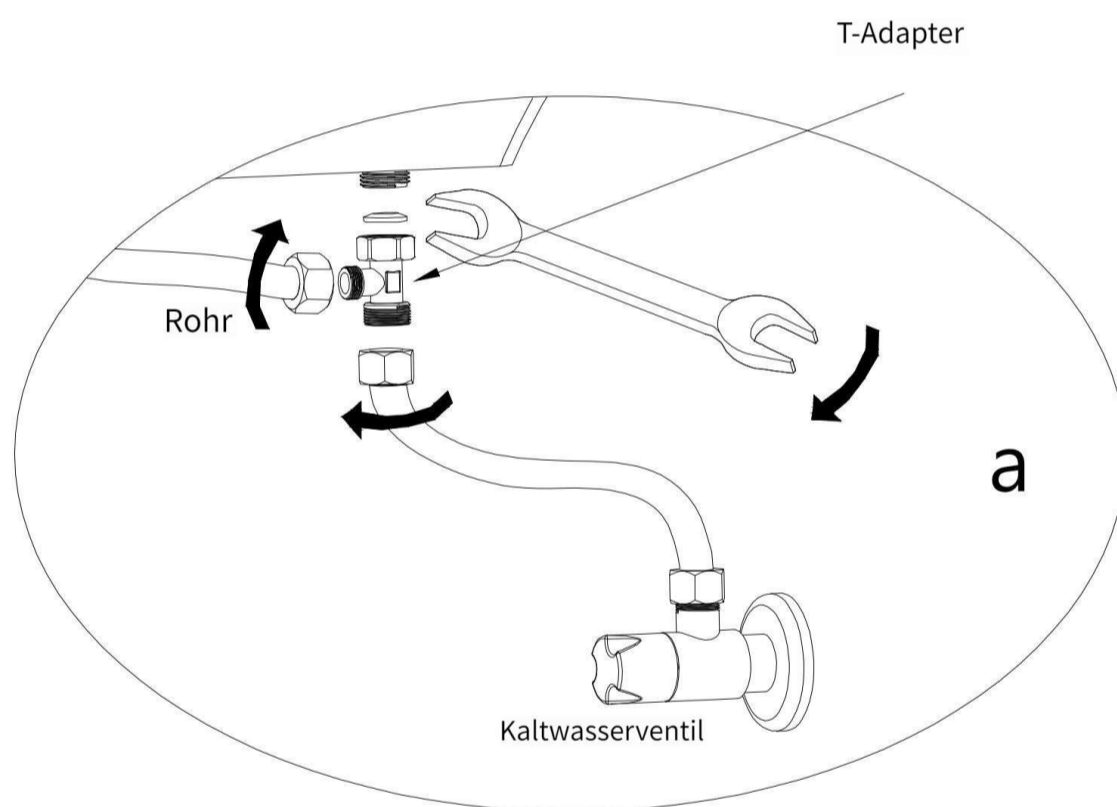
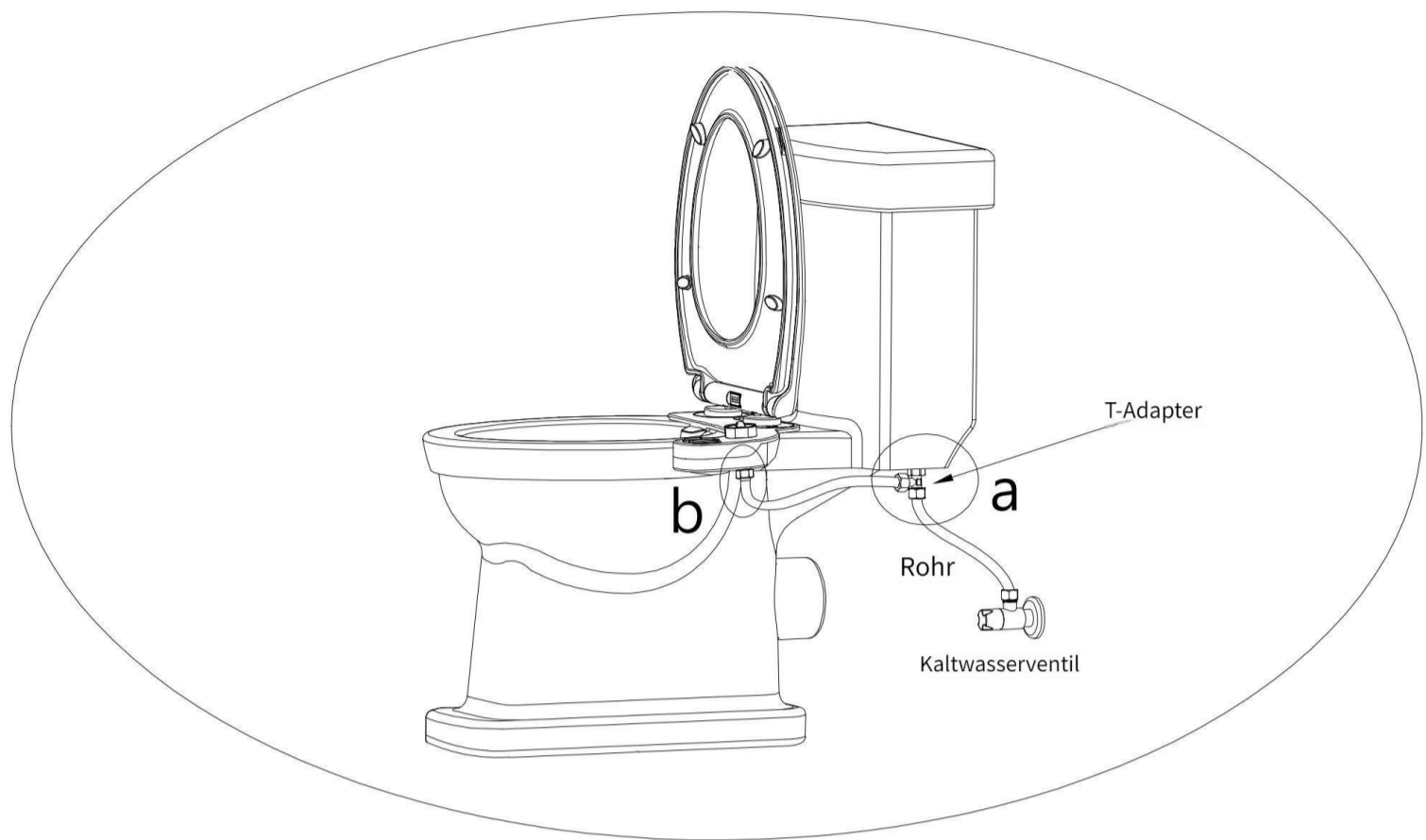

Warmwasser anschließen

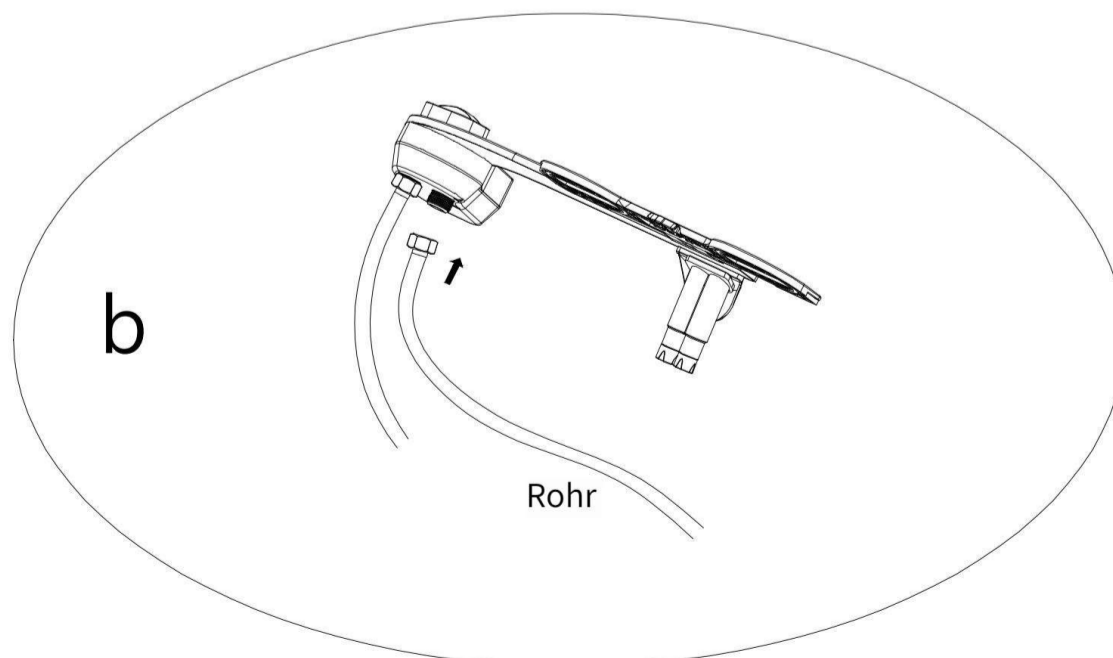
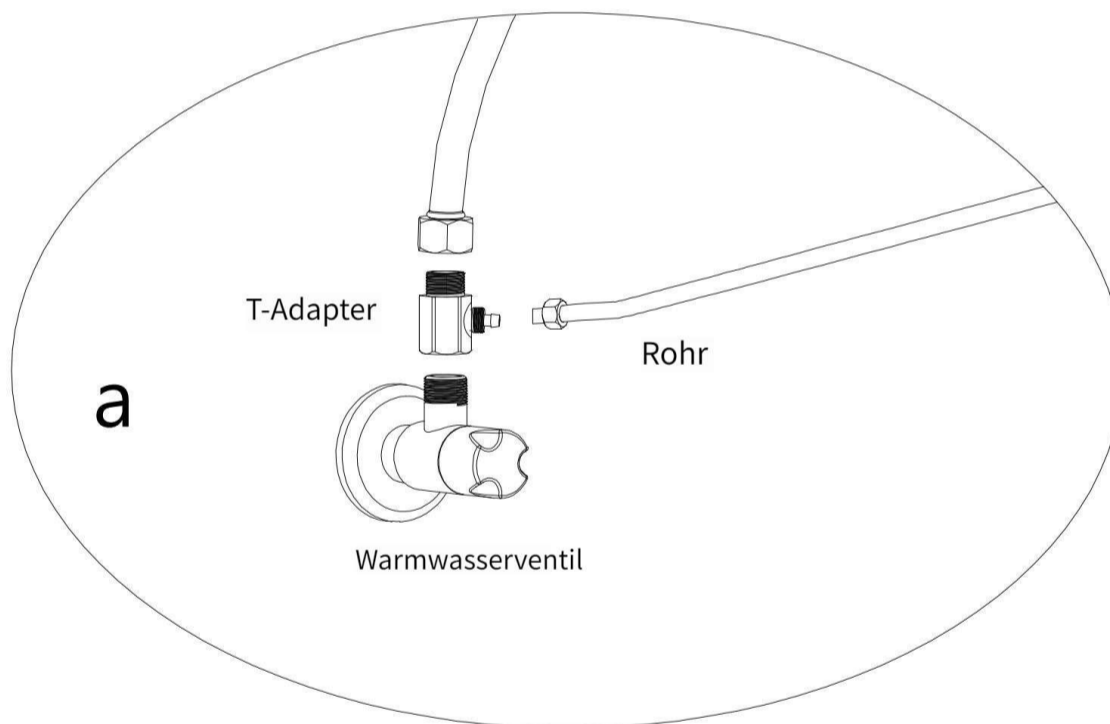
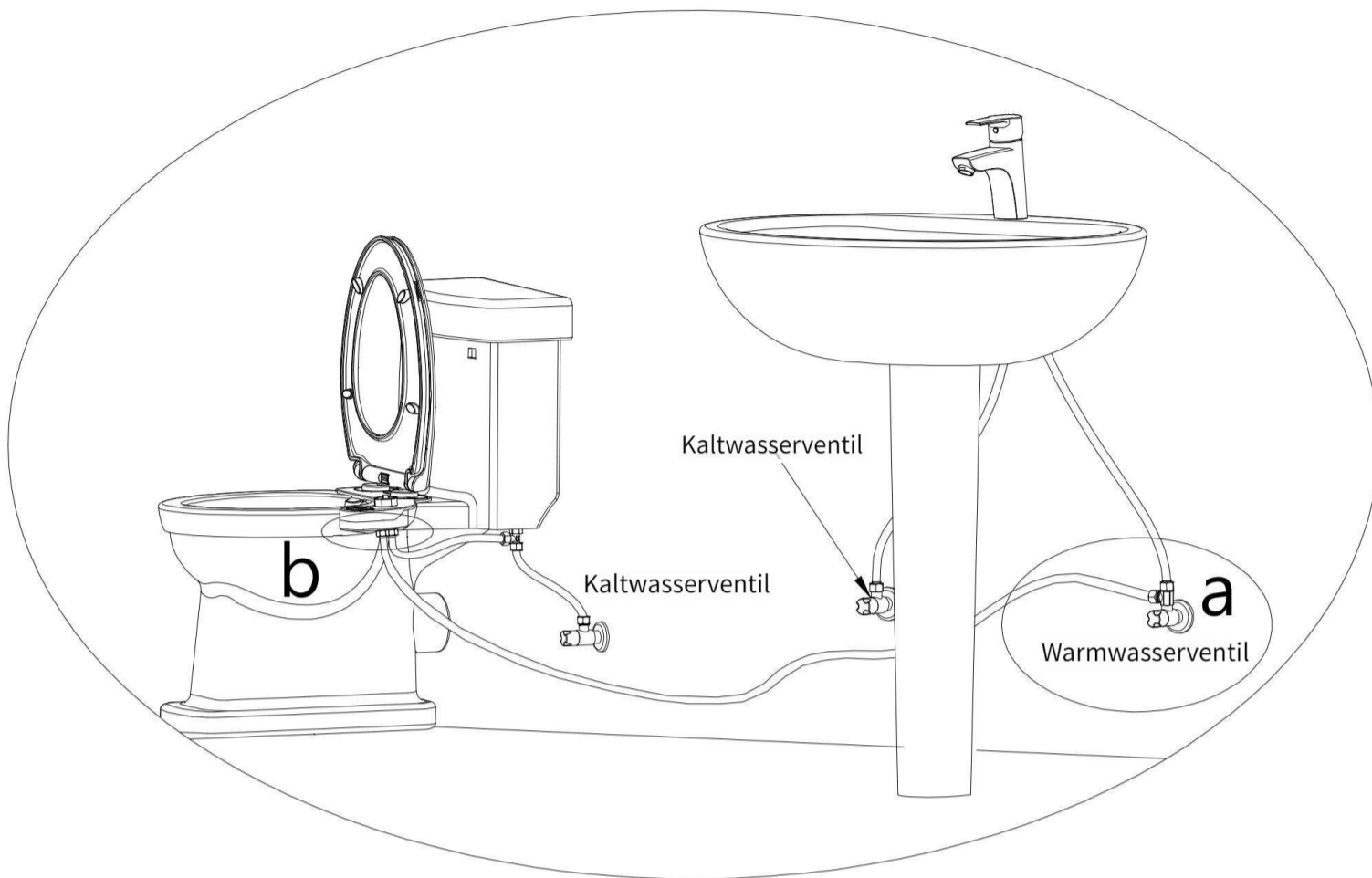

Schnelle Veröffentlichung

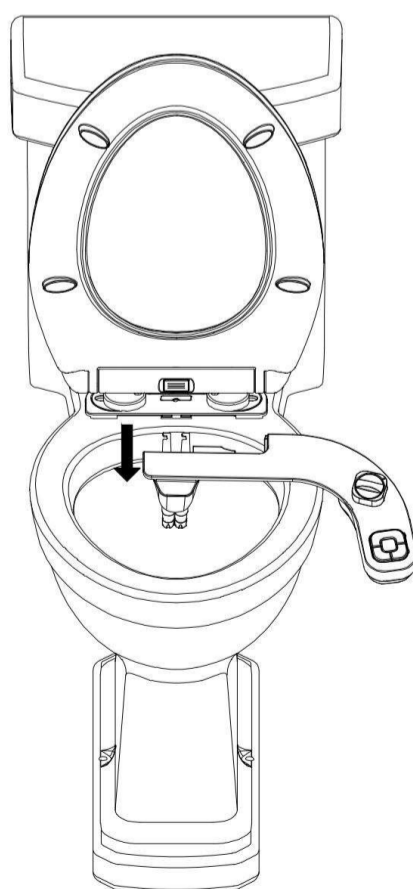
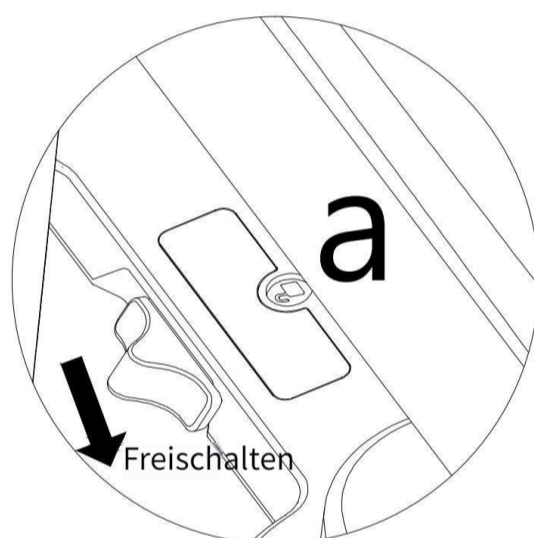
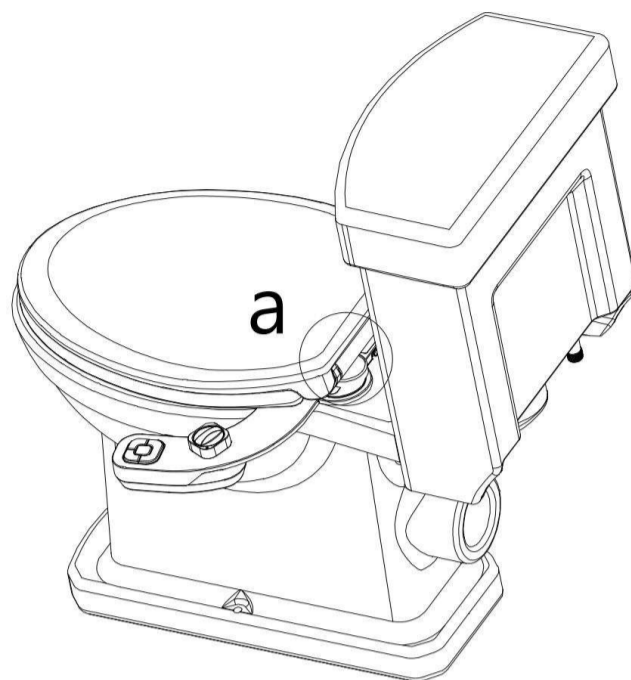

Schnelle Installation

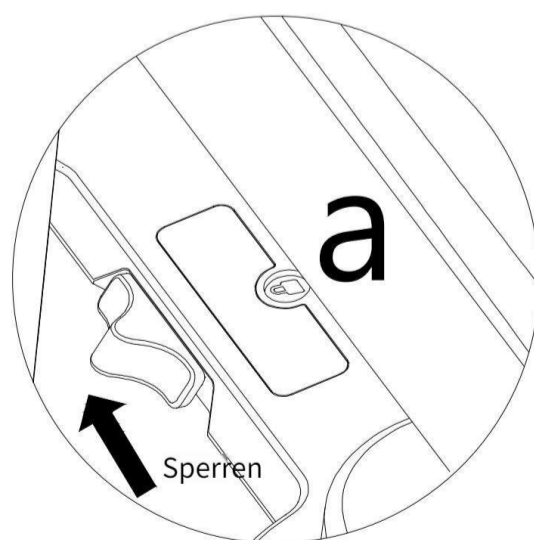
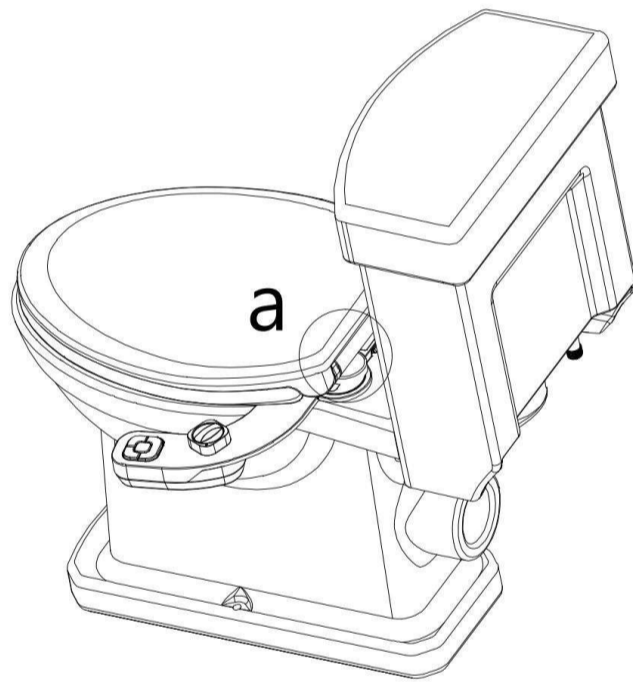
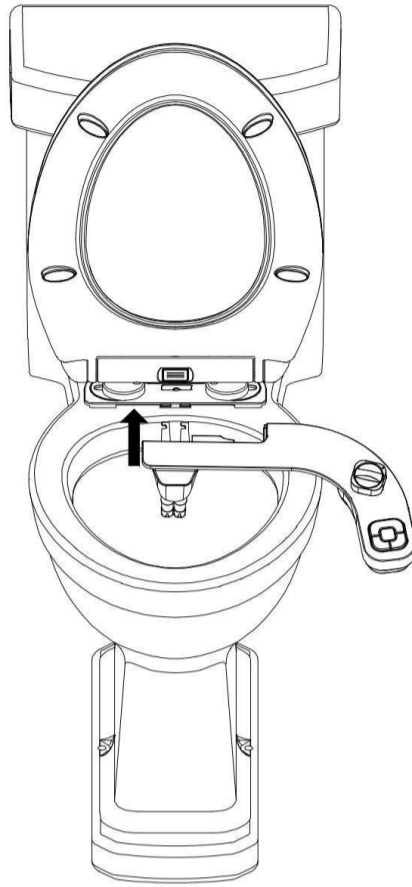

Betriebs Anweisungen



1. Düsenfunktion mit der Taste auswählen.

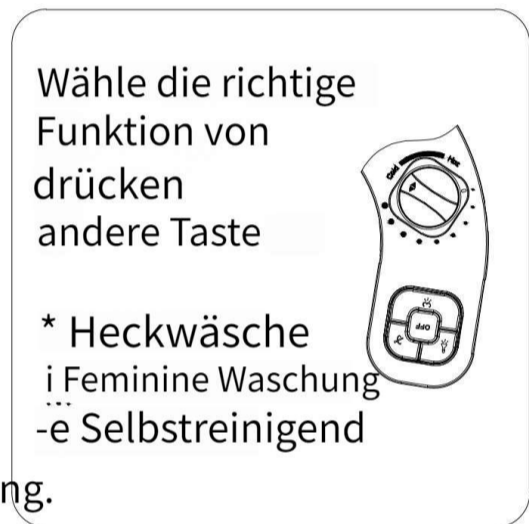
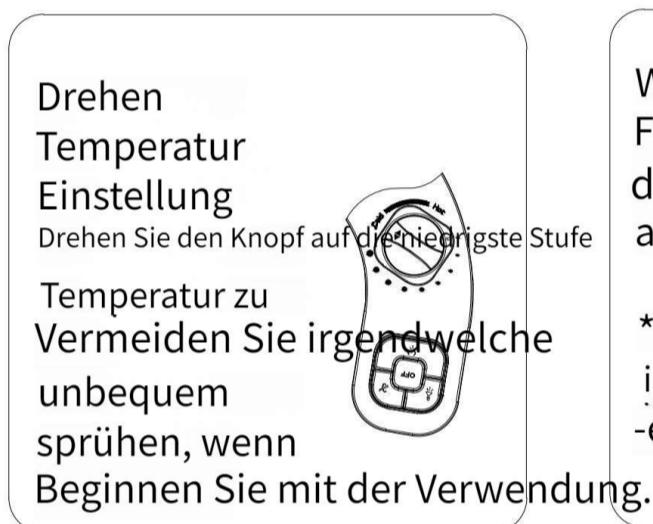
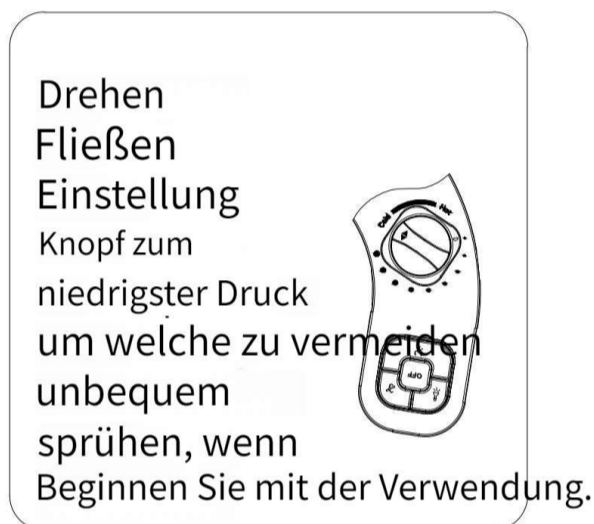

2. Stellen Sie den Wasserfluss ein.



3. So lange wie nötig verwenden.



MANUEL D'INSTRUCTIONS

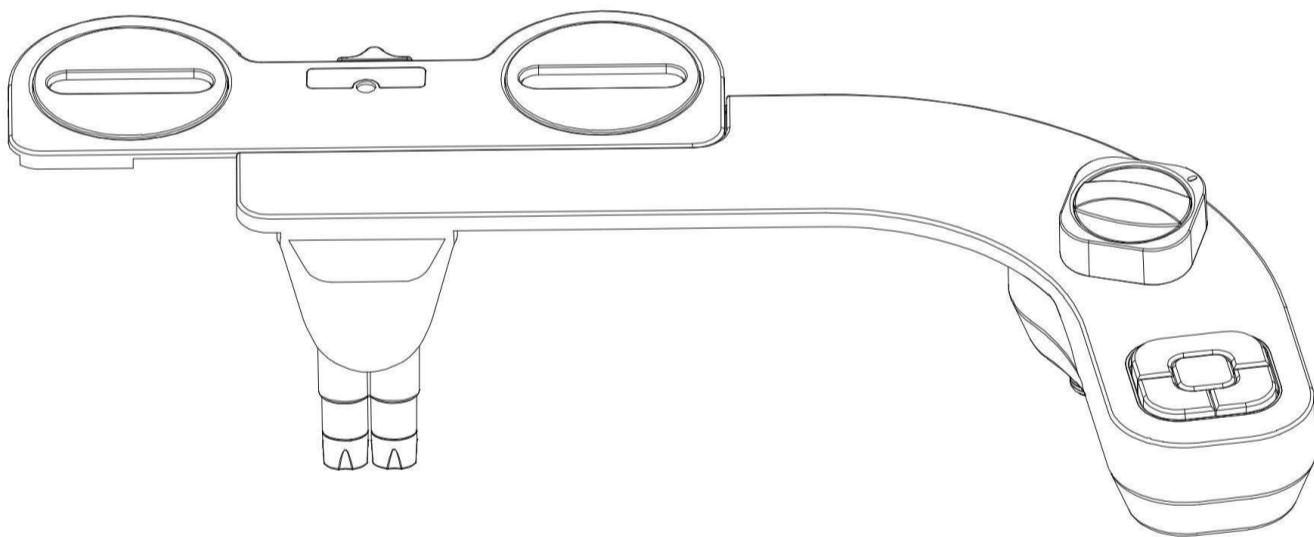

Noms et fonctions des pièces

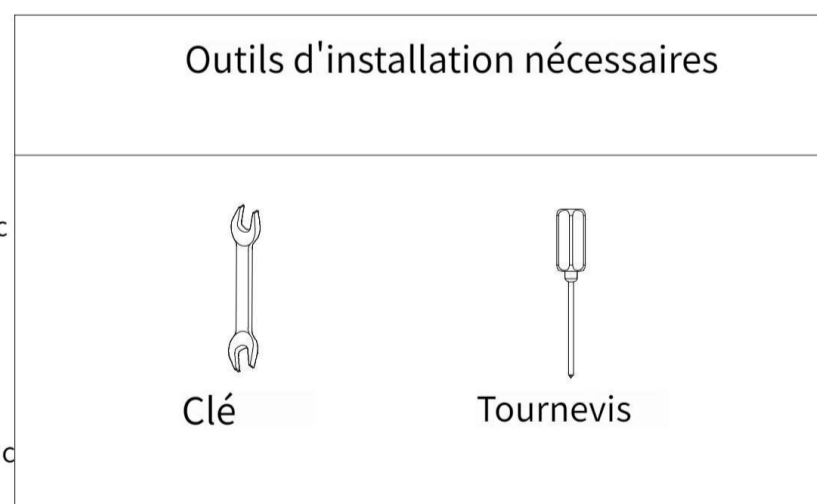
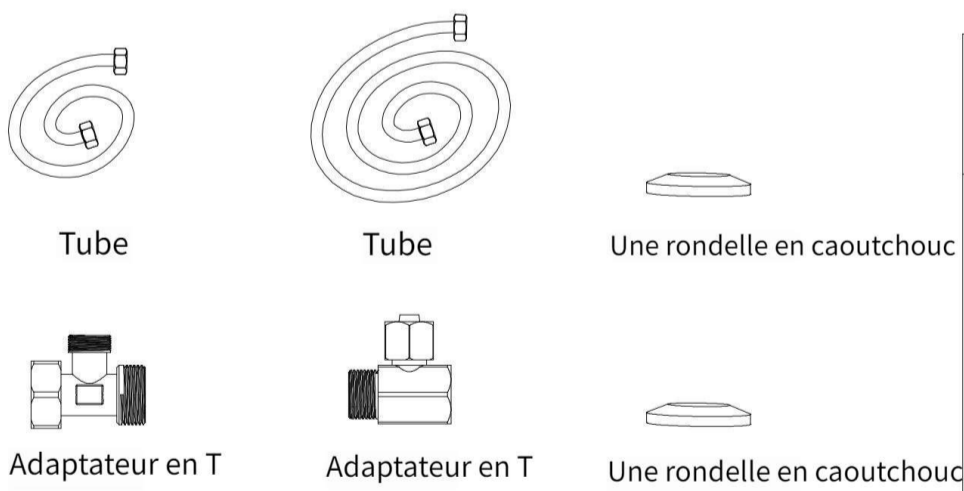
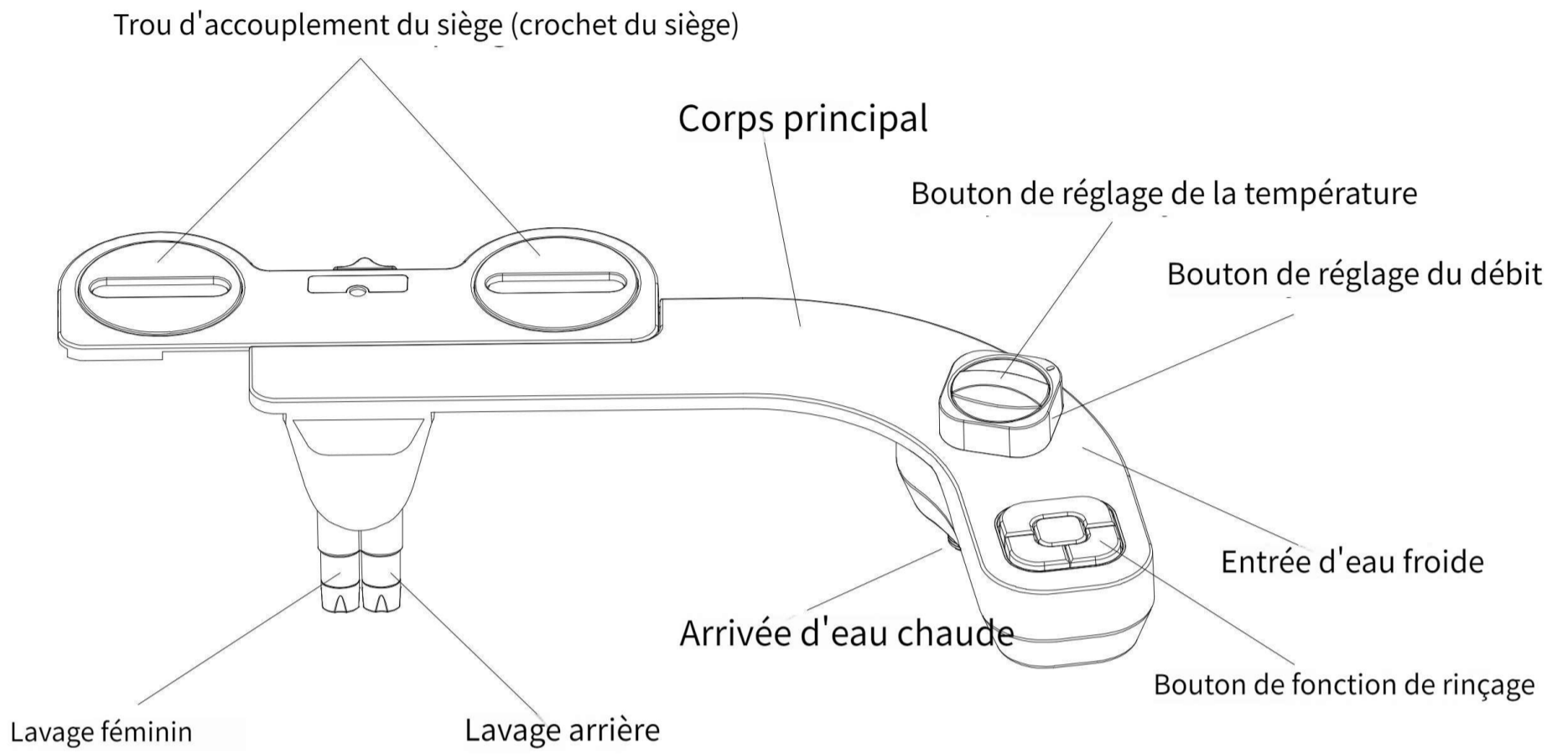

Installer le bidet

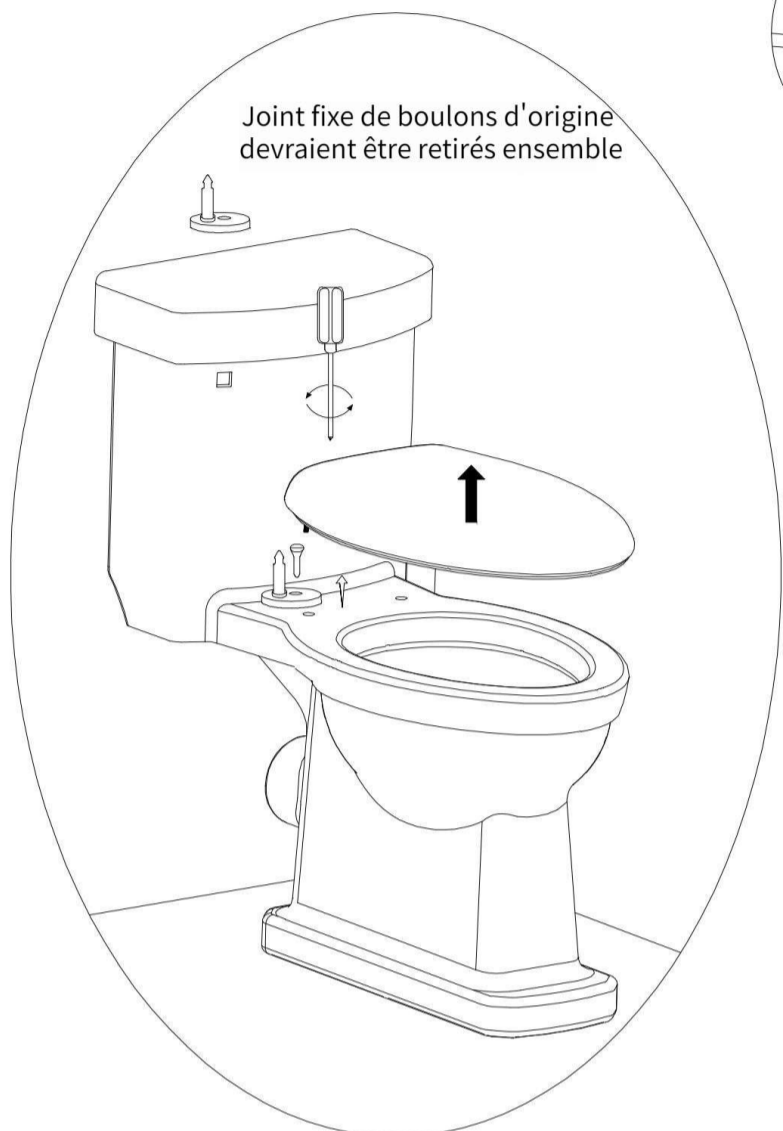

a

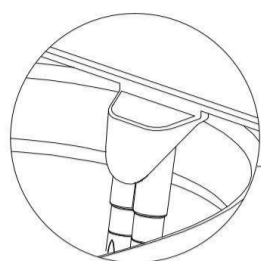

Ajuster la buse position et essayez de rapproche-le du rebord des toilettes.

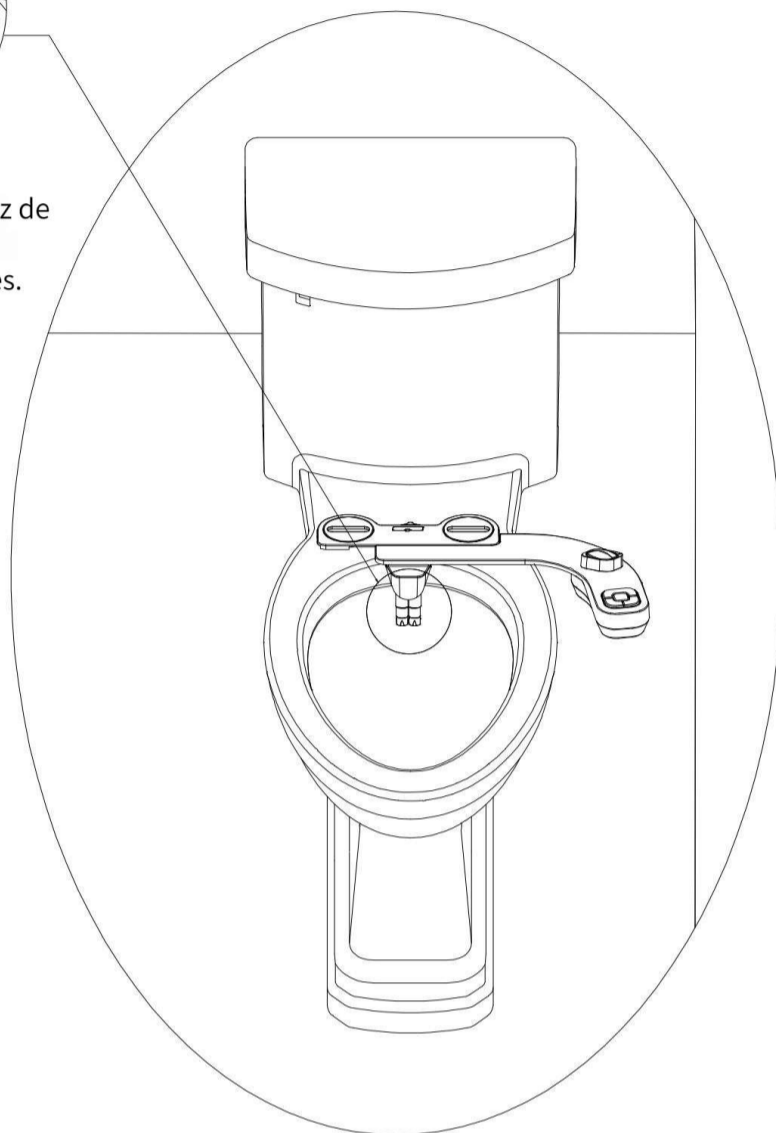

b

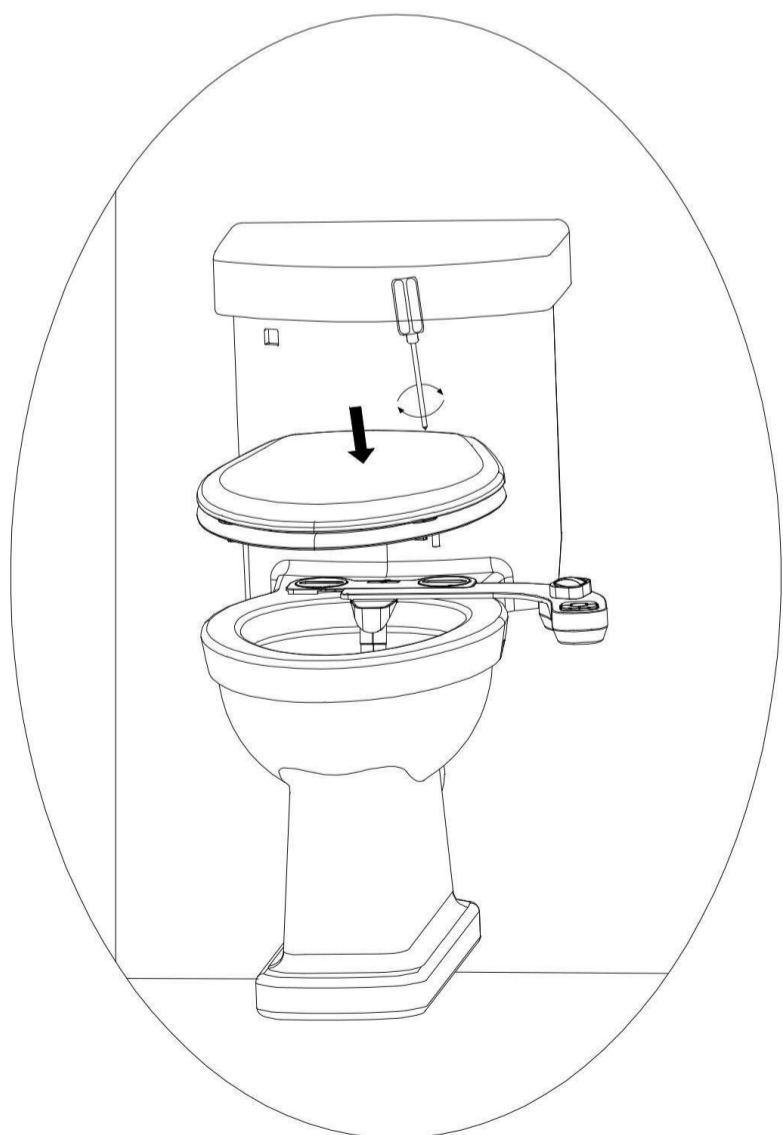

c



d

Connecter l'eau froide

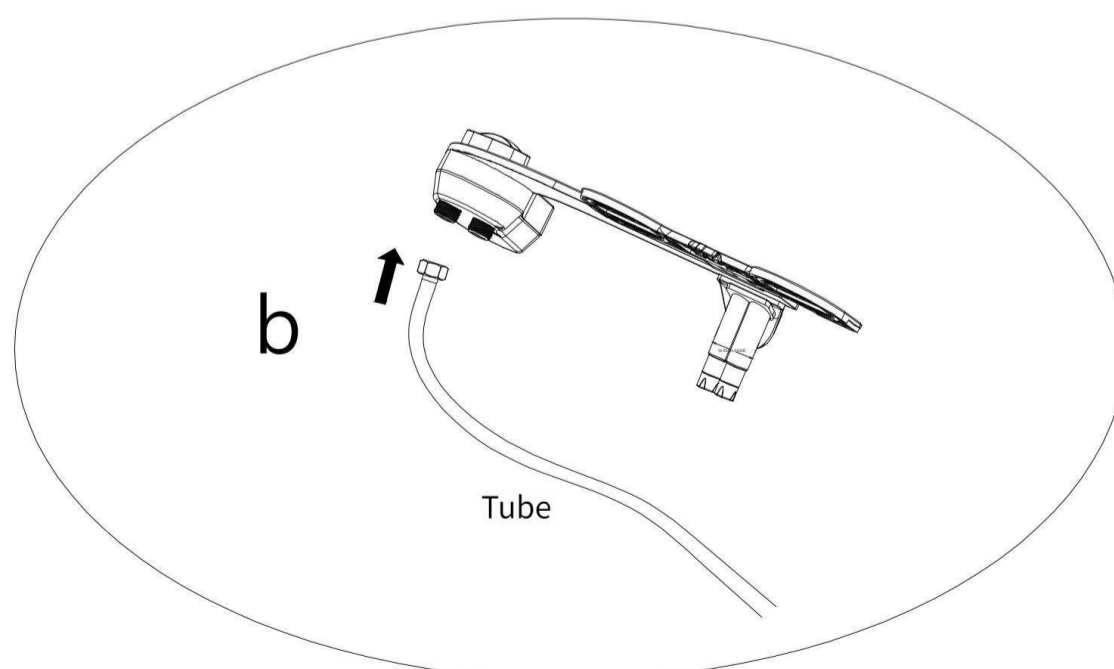
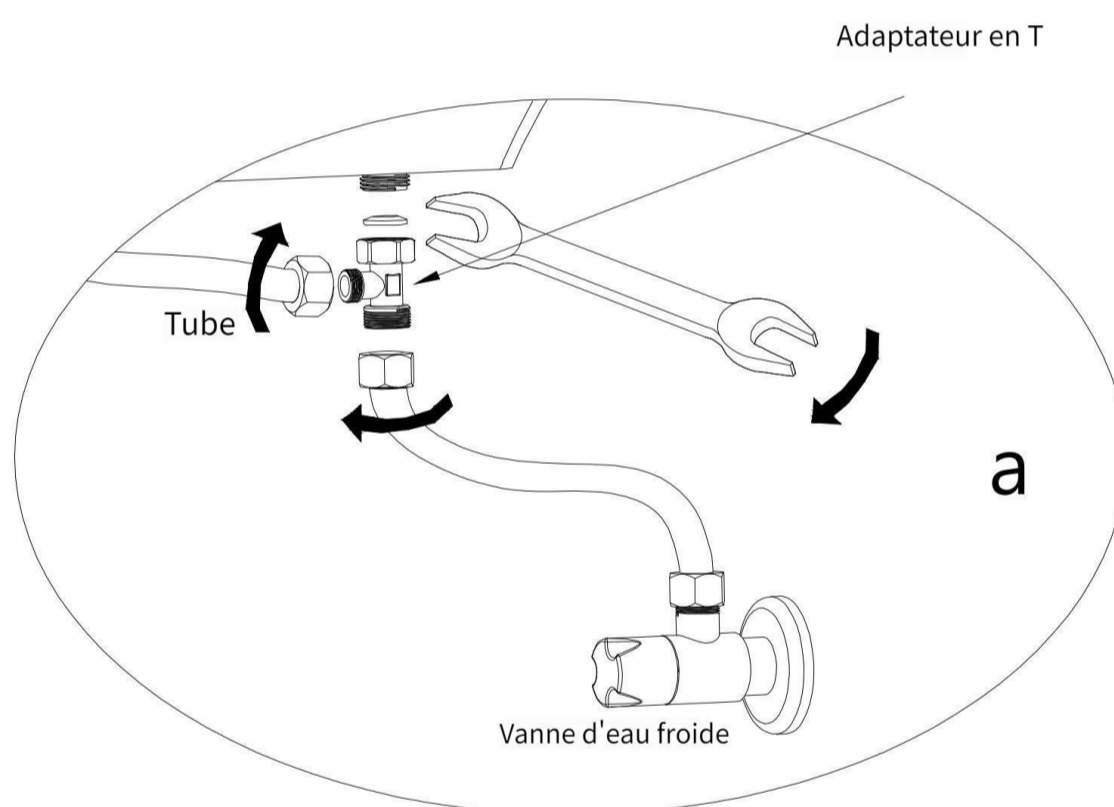
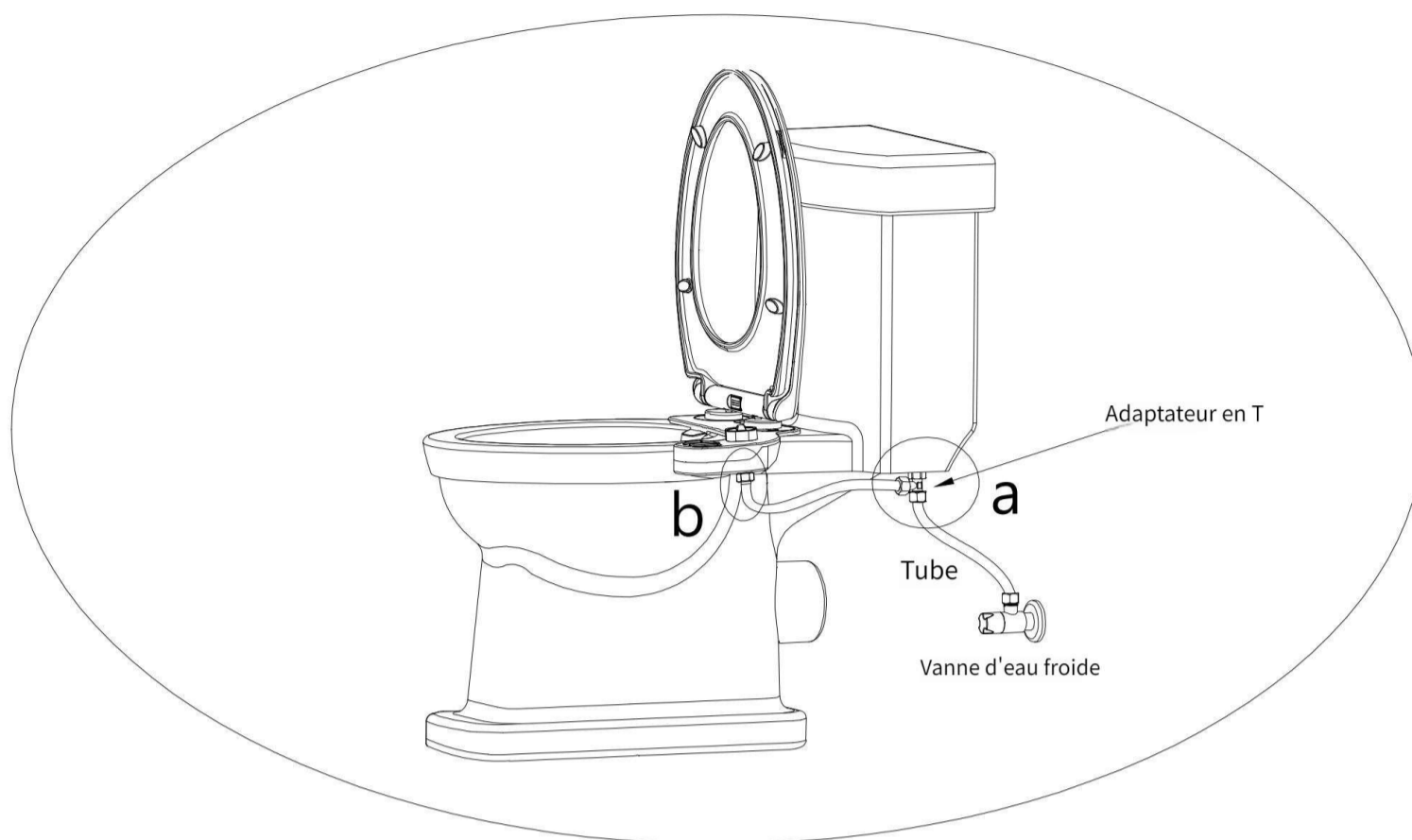

Connecter l'eau chaude

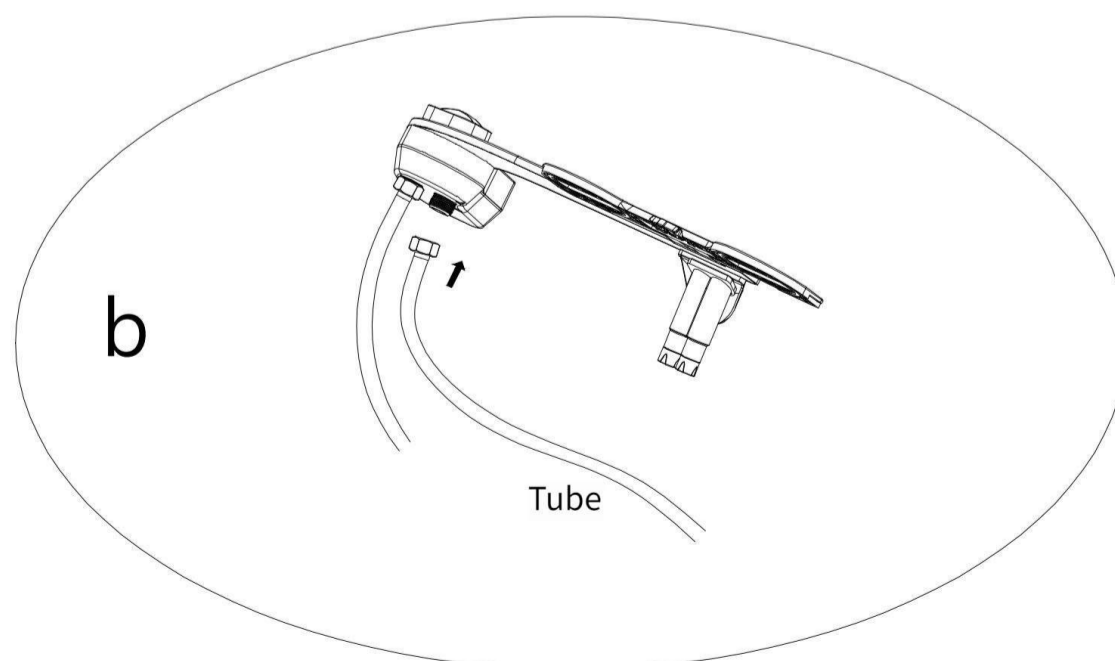
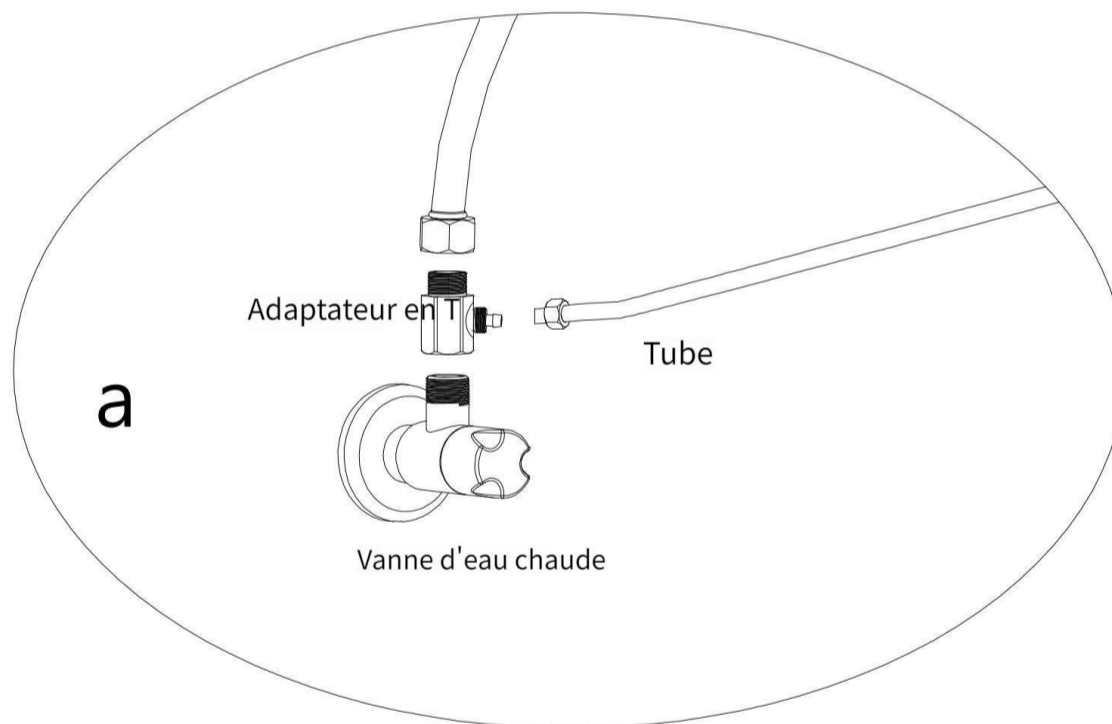
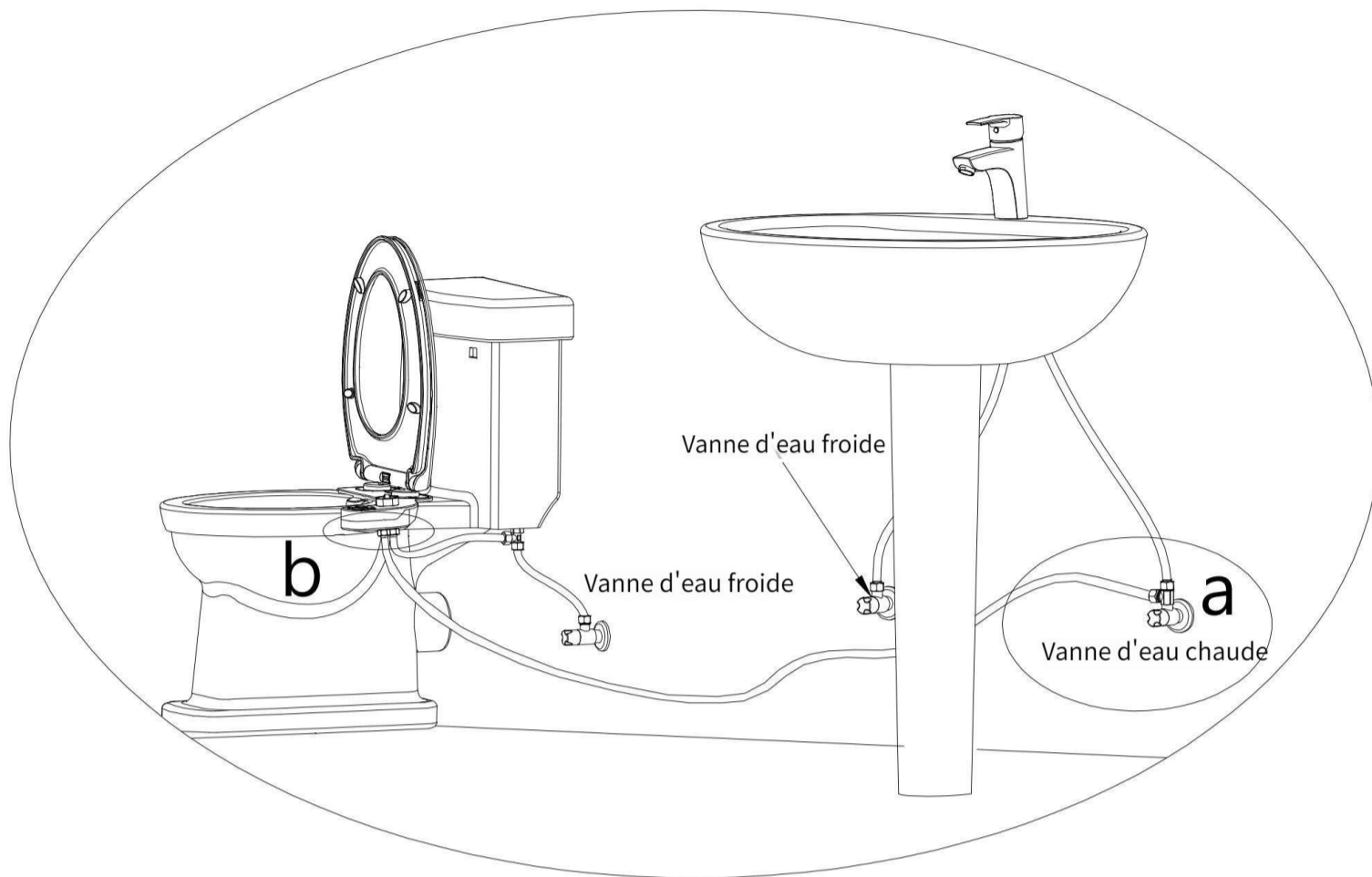

Libération rapide

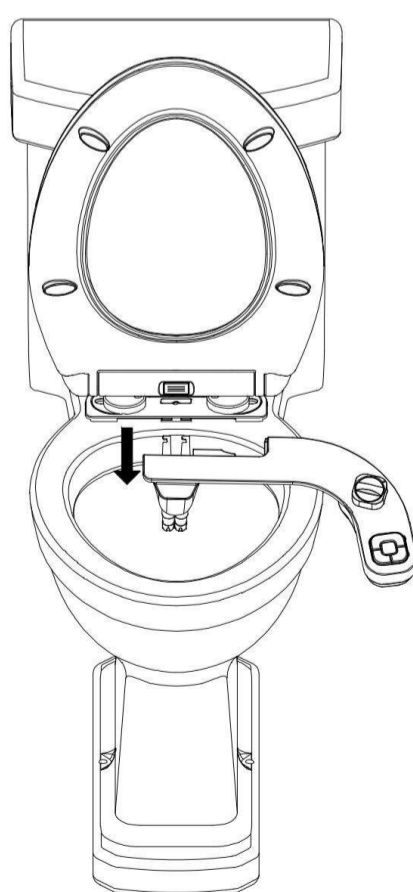
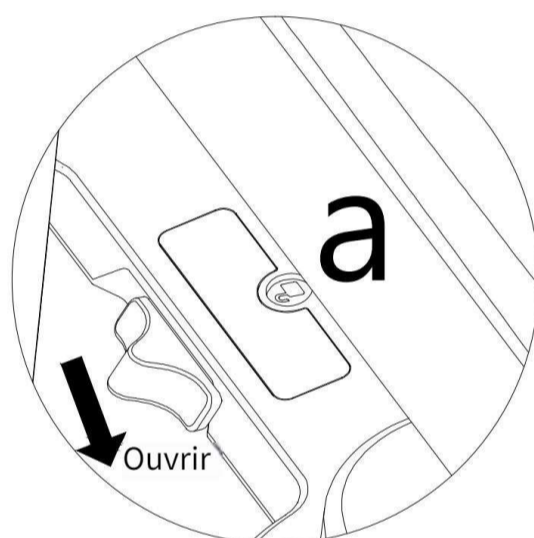
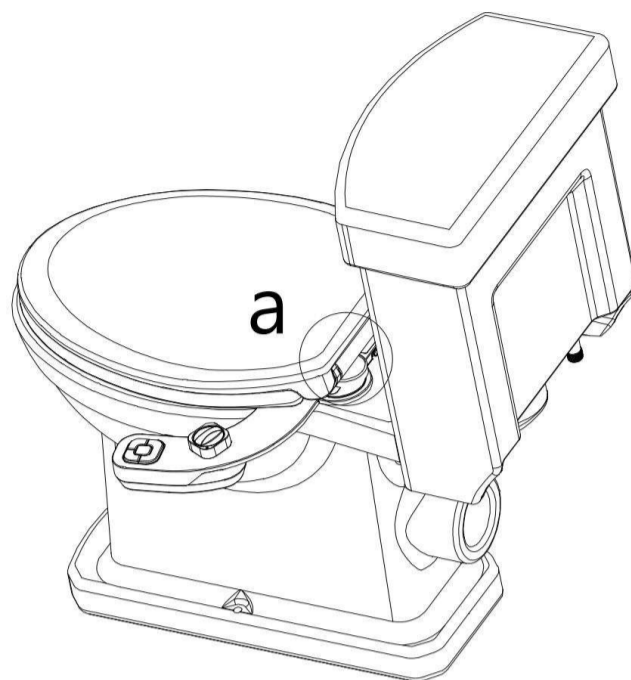

Installation rapide

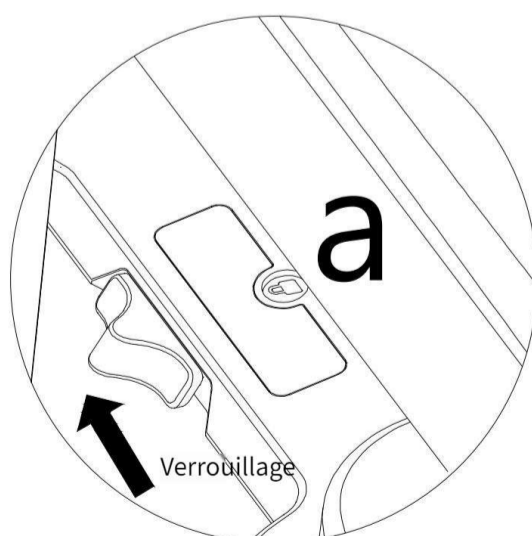
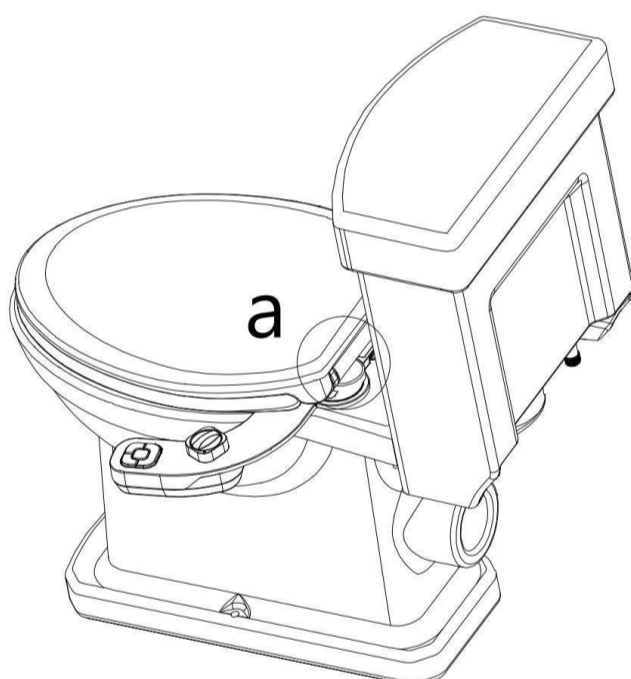
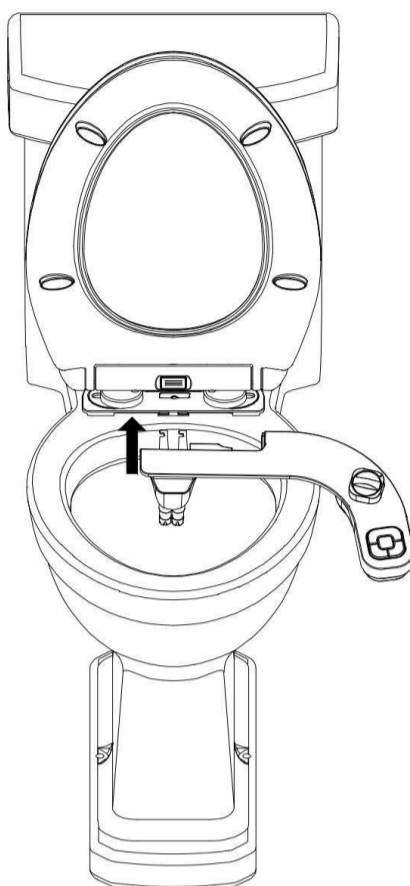

en fonctionnements



1. Sélectionnez la fonction de buse à l'aide du bouton .

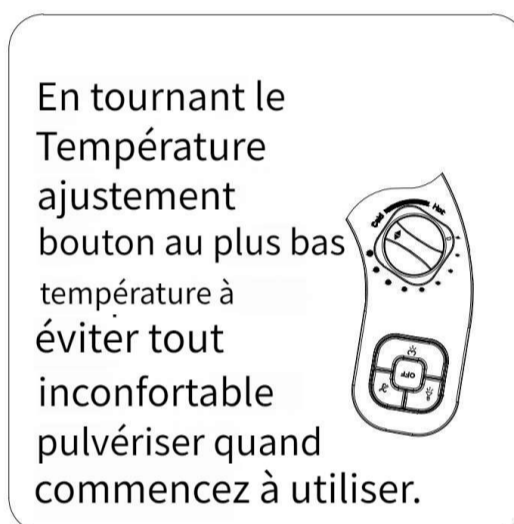

2. Réglez le débit d'eau.

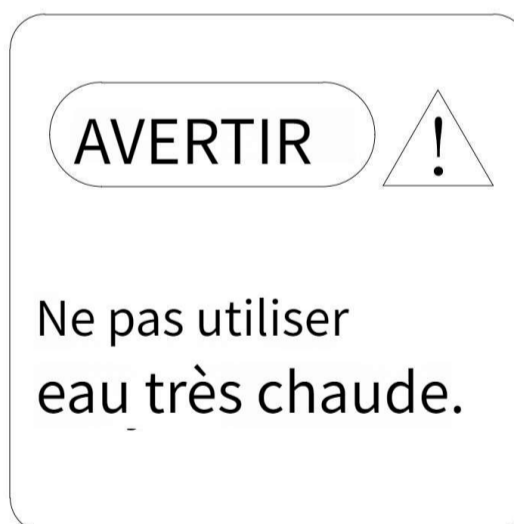

3. Utiliser aussi longtemps que nécessaire.

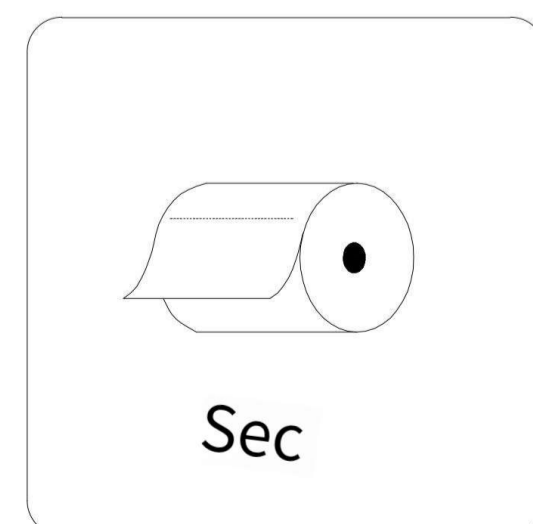
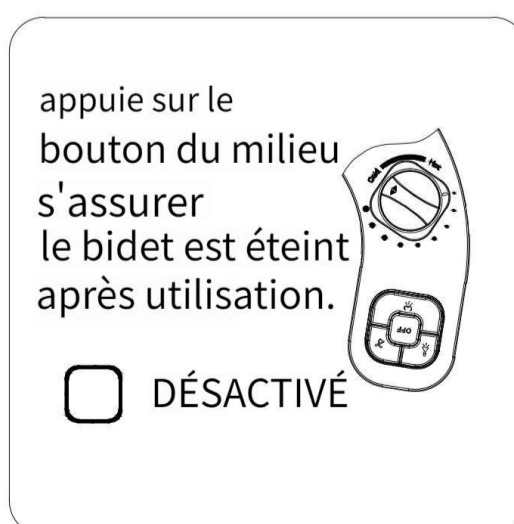

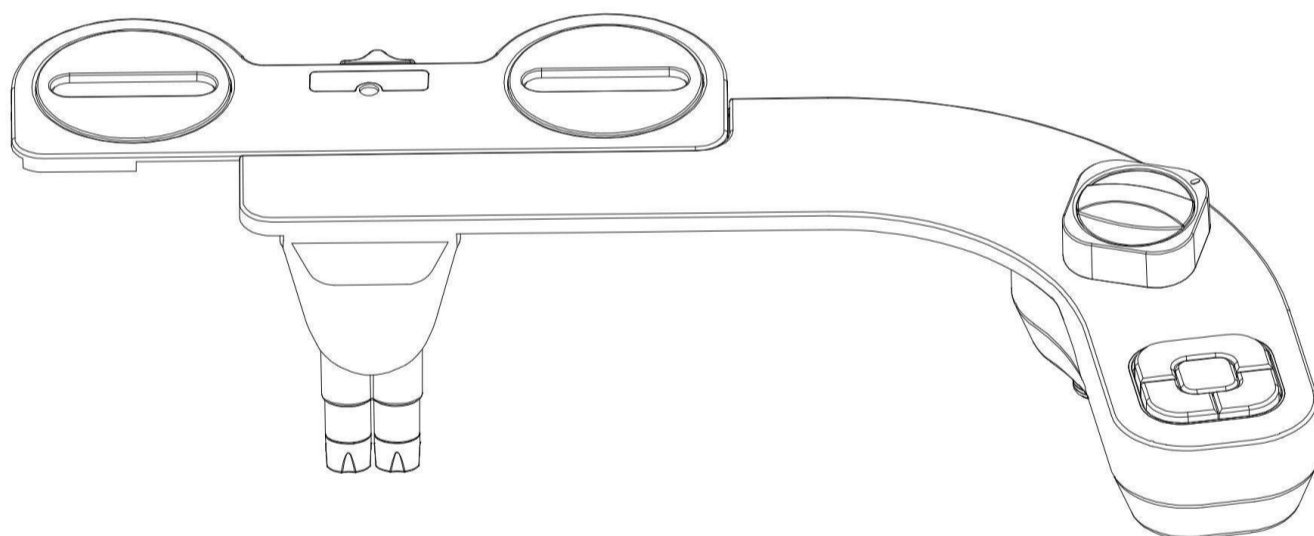

取扱説明書

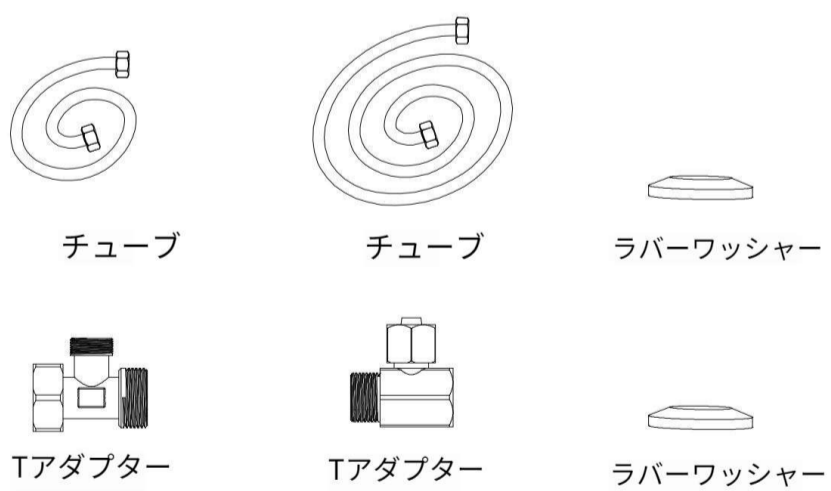
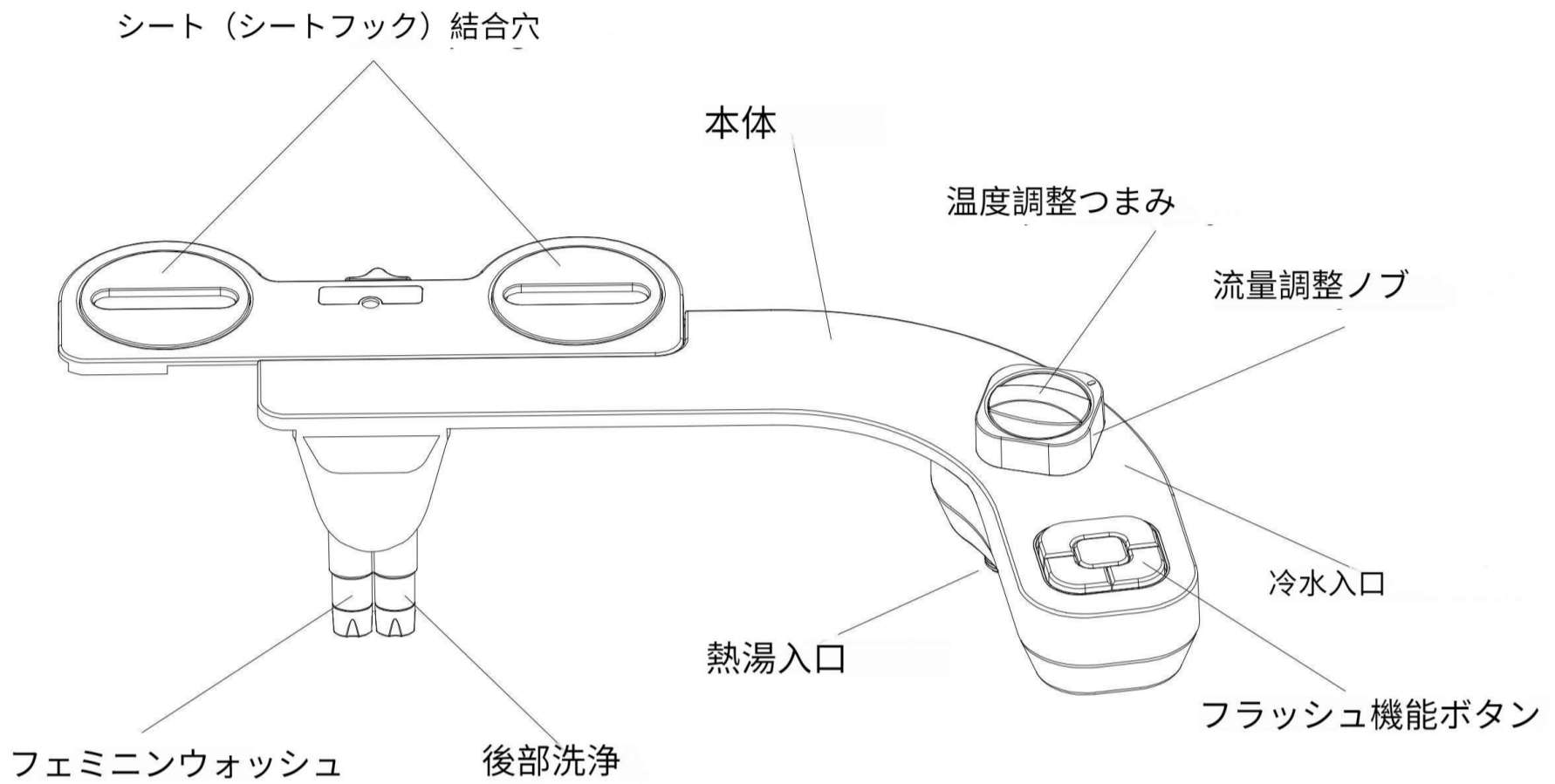

各部の名称と機能



必要なインストールツール	
	
レンチ	ドライバー

ビデを設置する

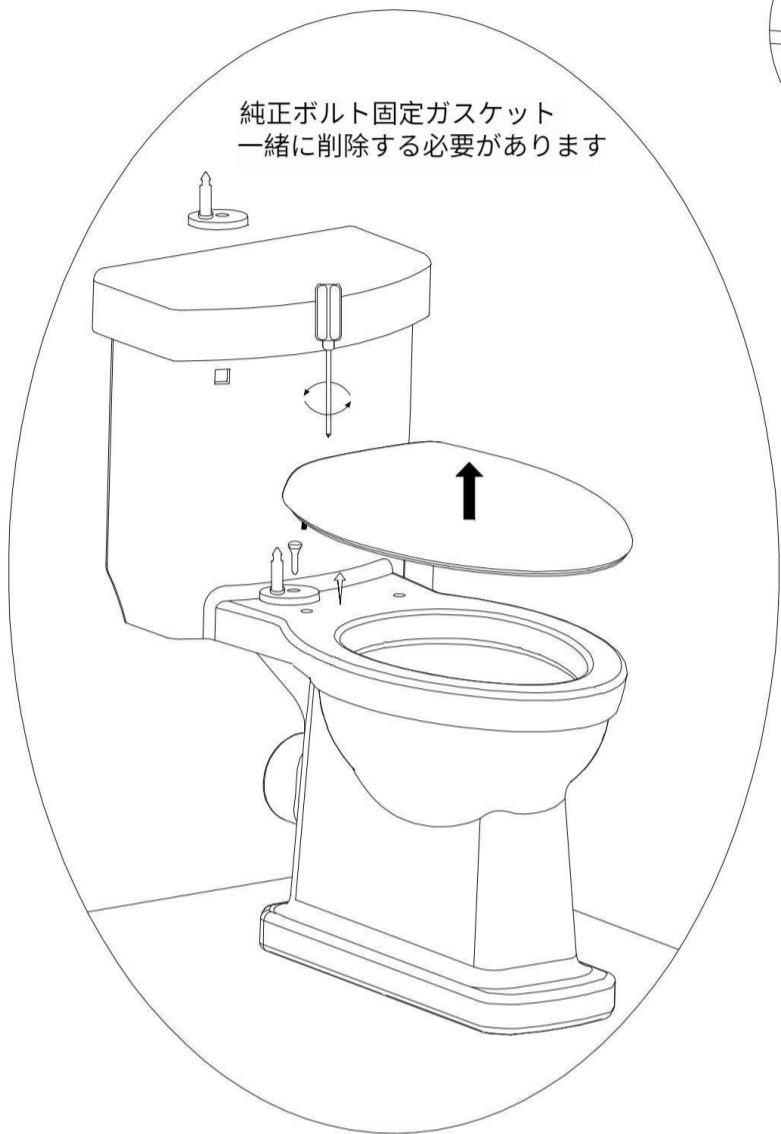

a

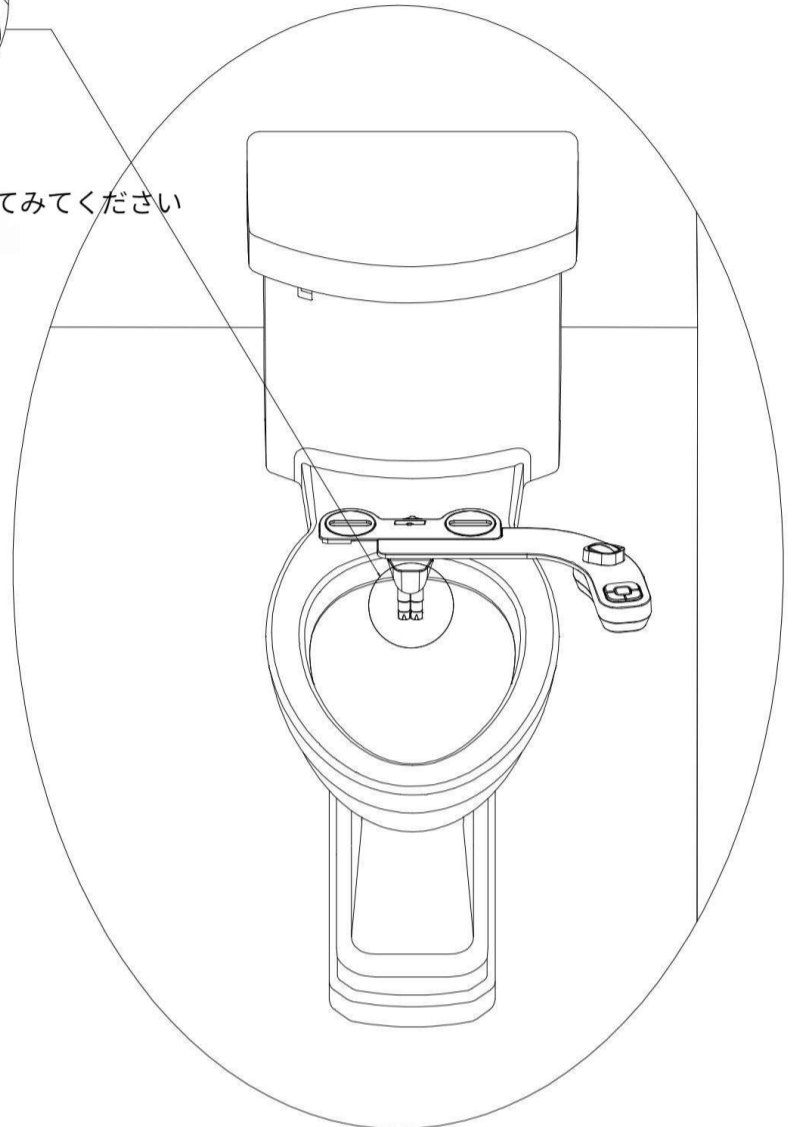
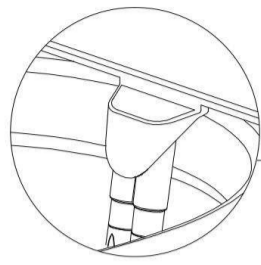

b

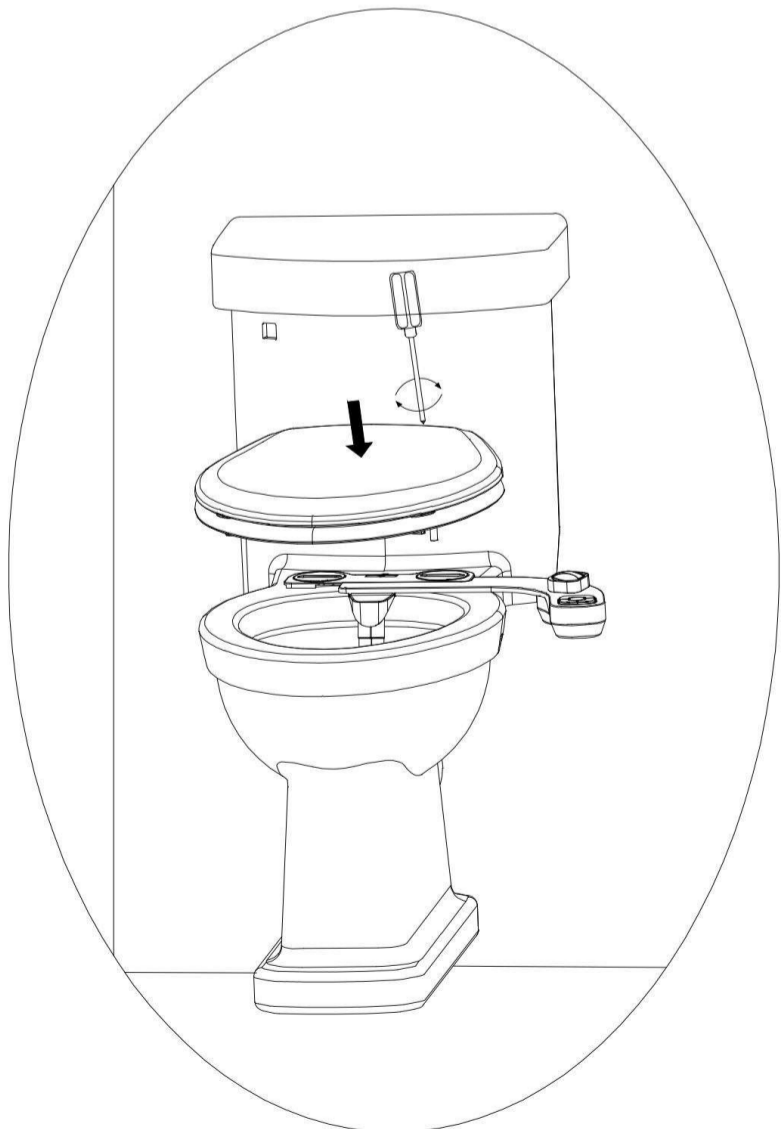

c

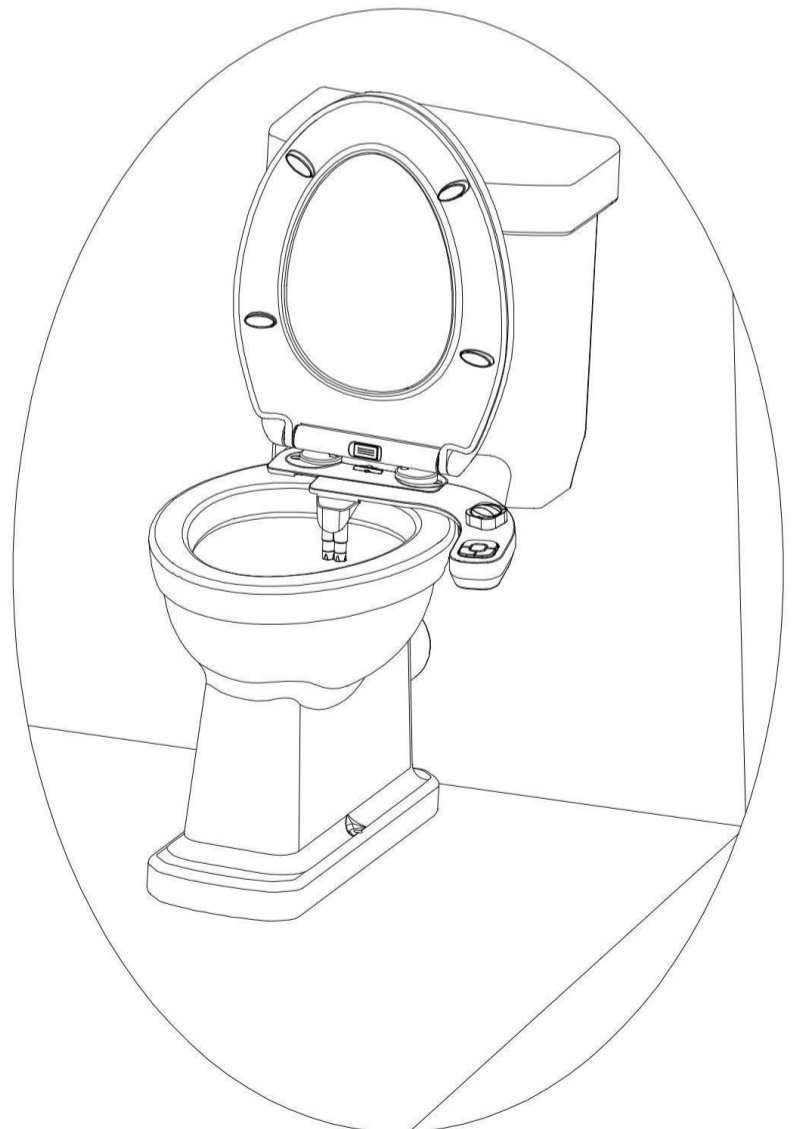

d

冷水を接続する

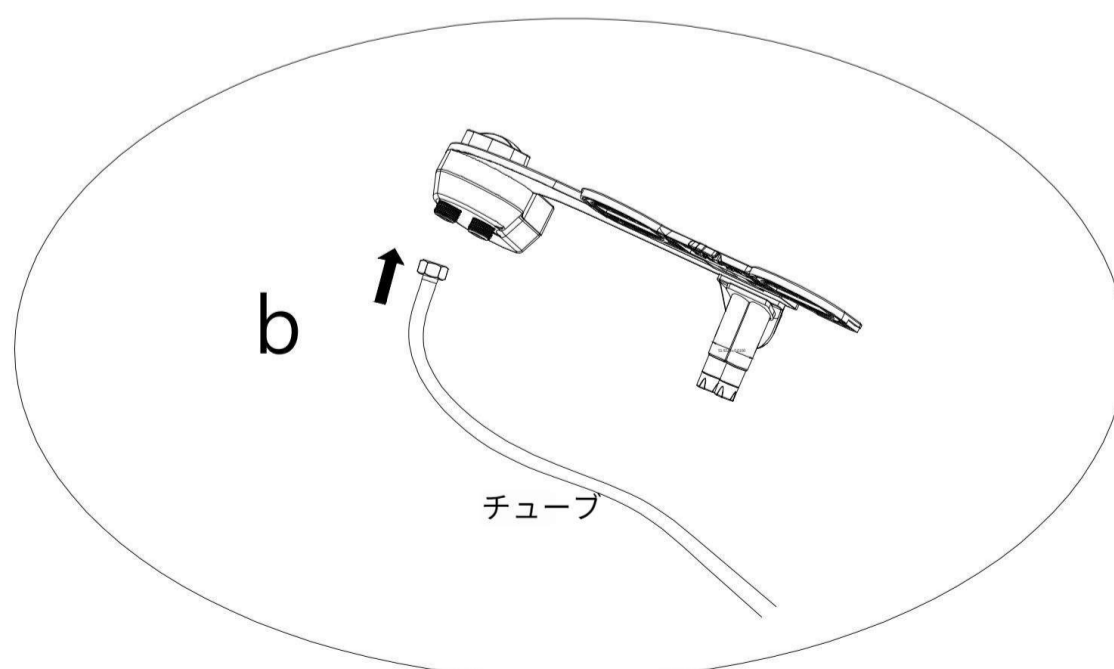
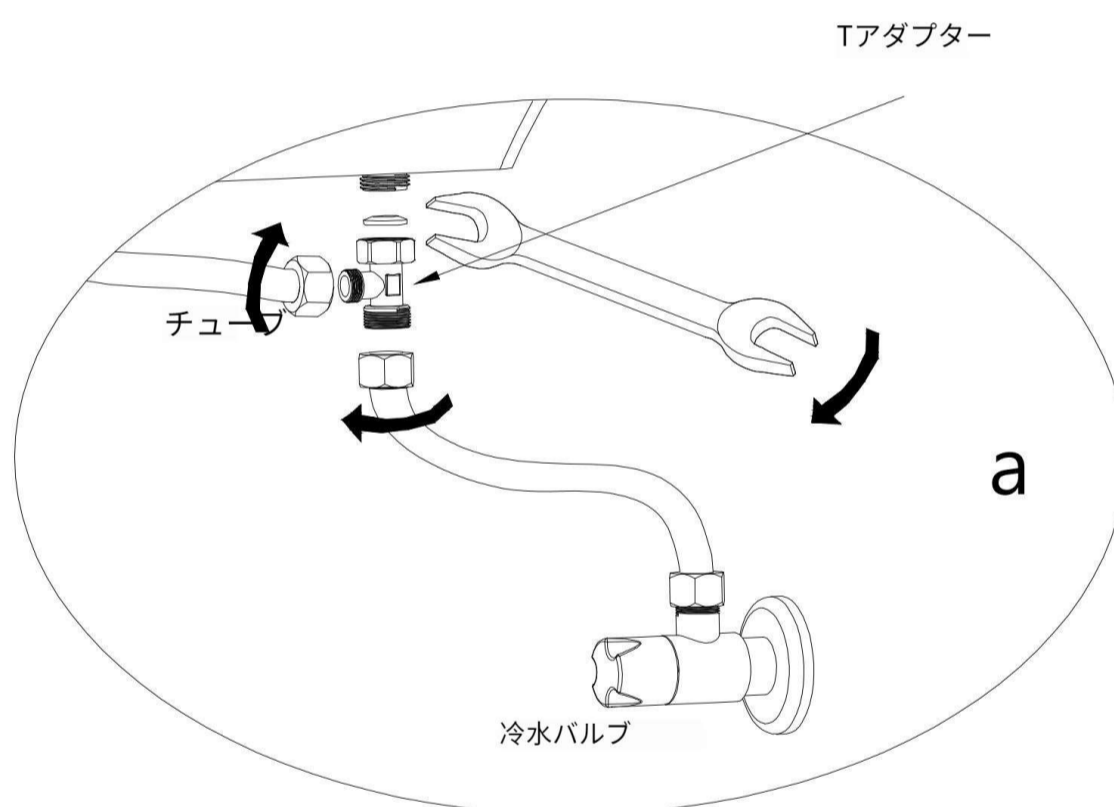
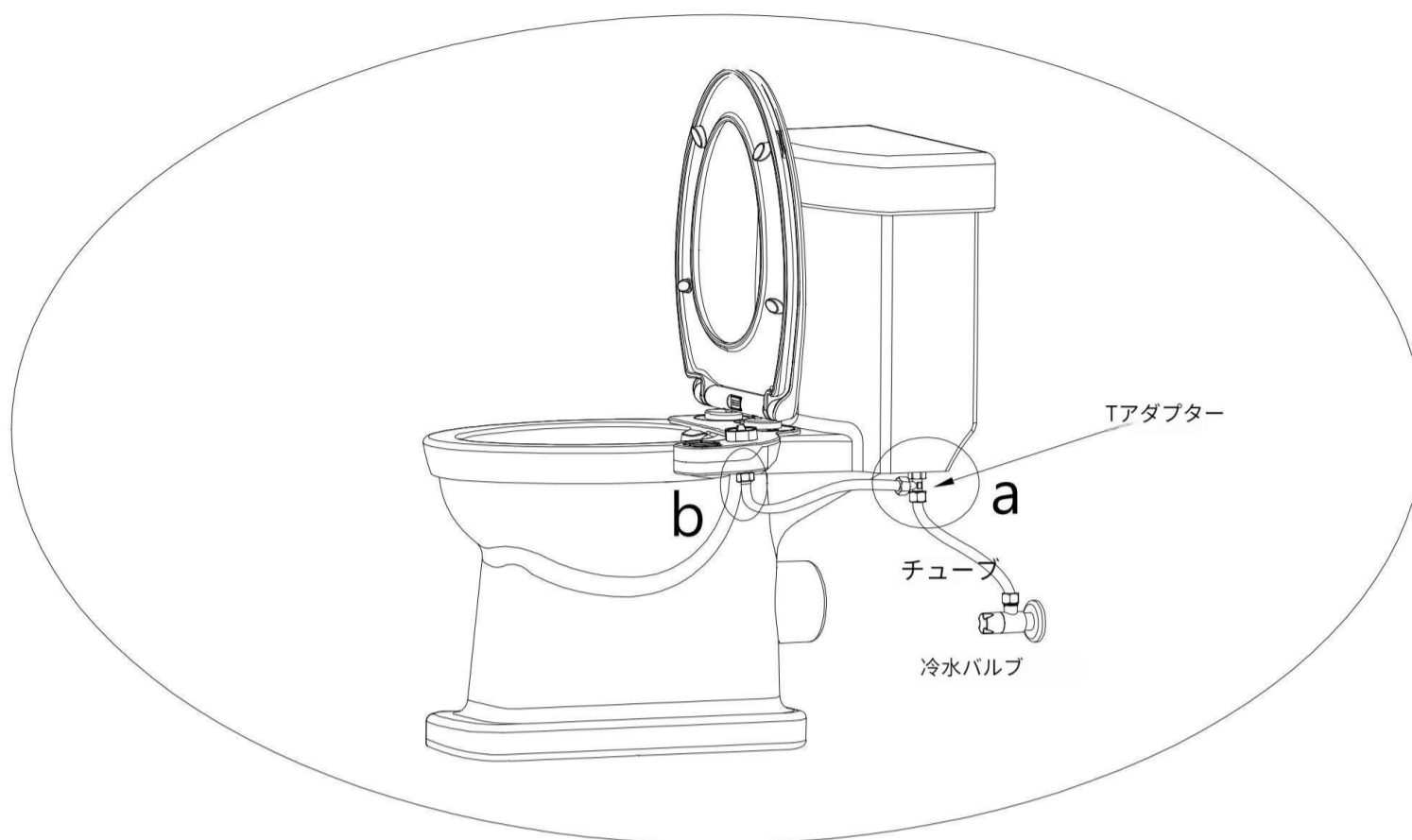

お湯を接続します

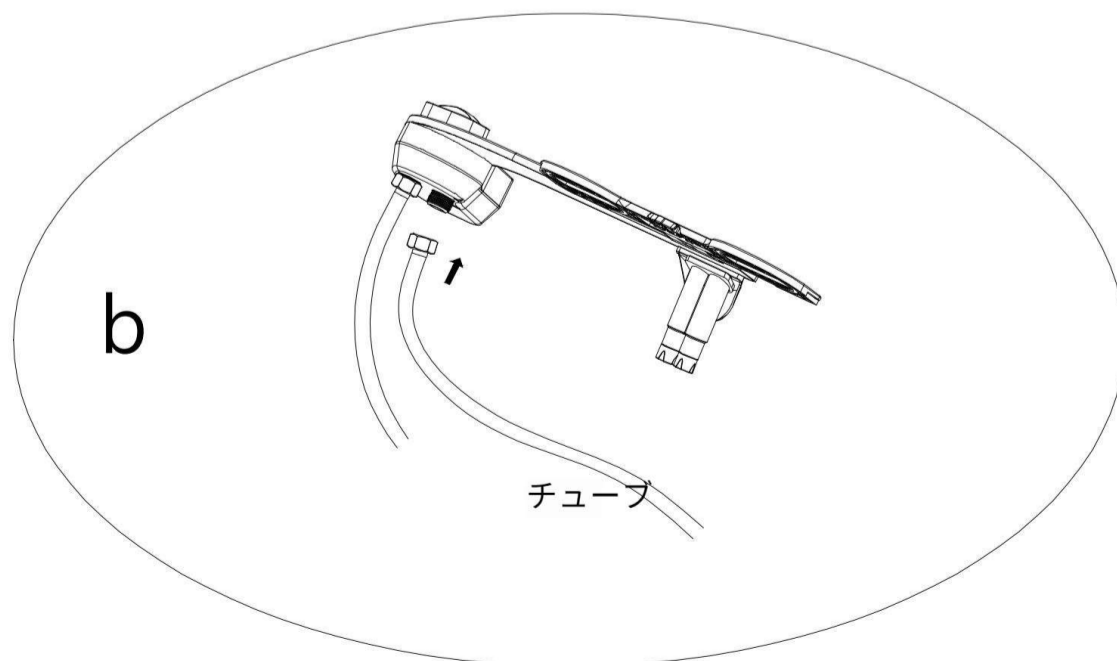
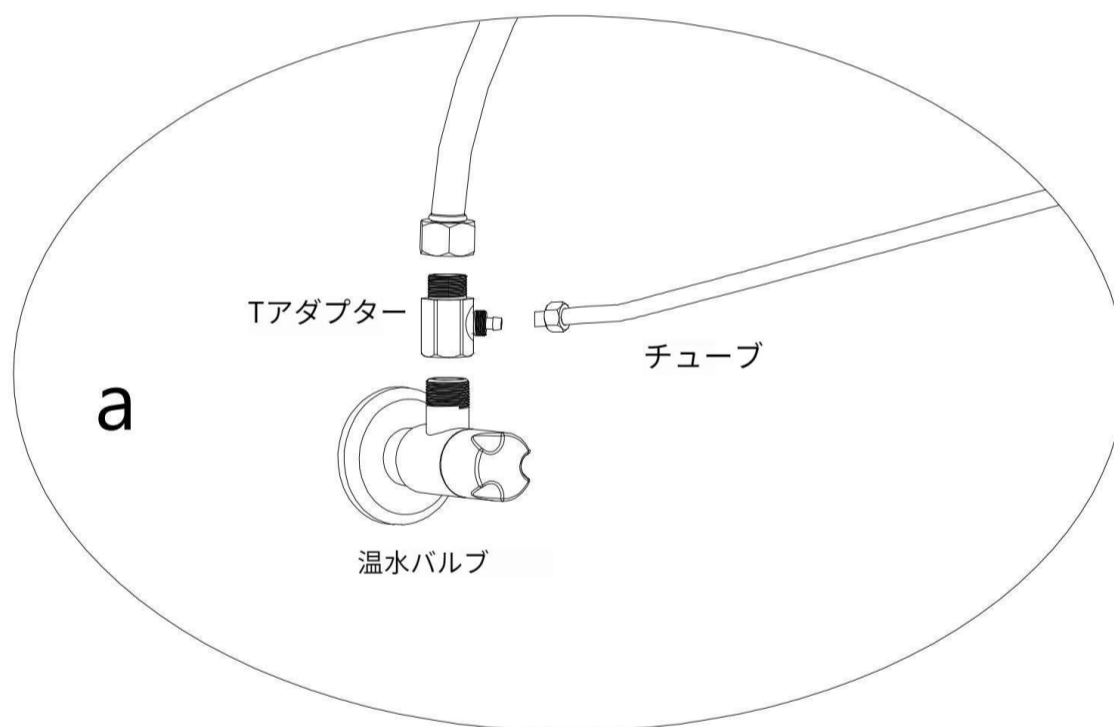
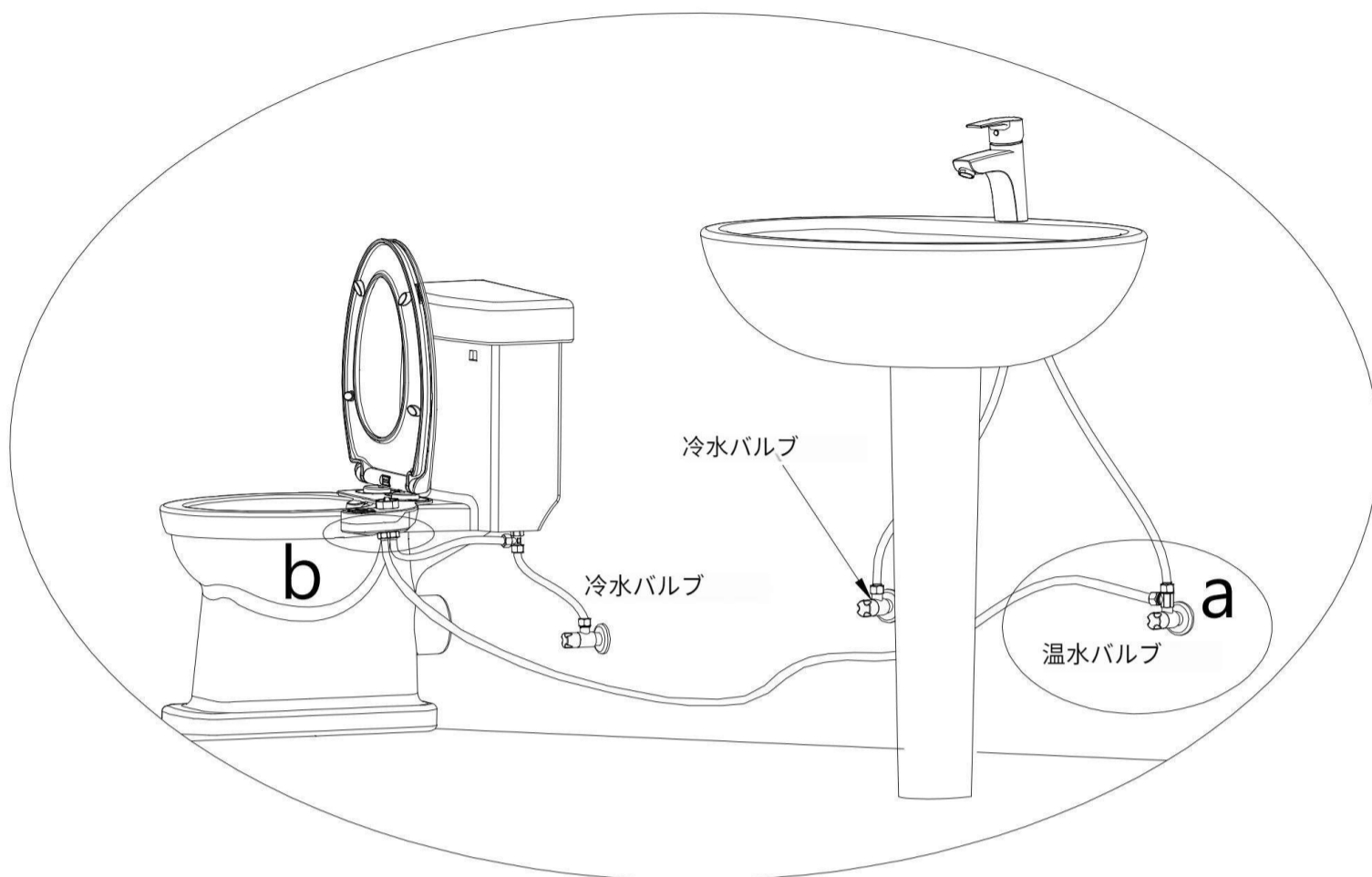

クイックリリース

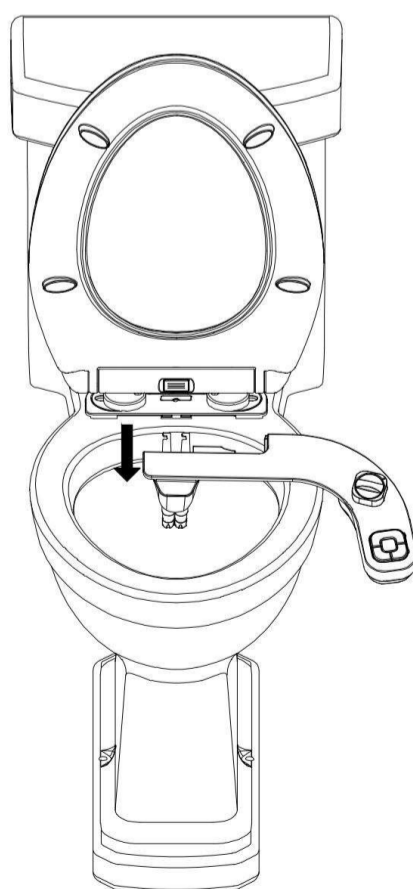
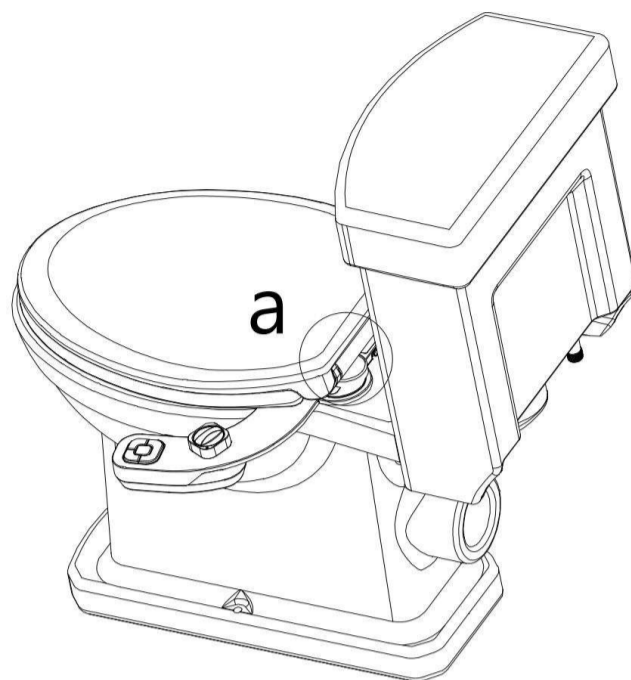

クイックインストール

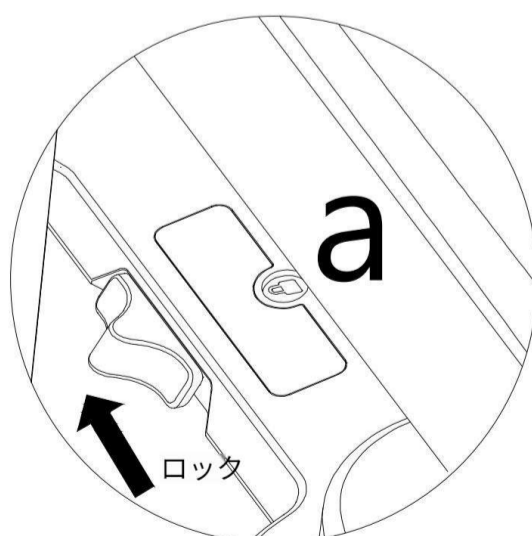
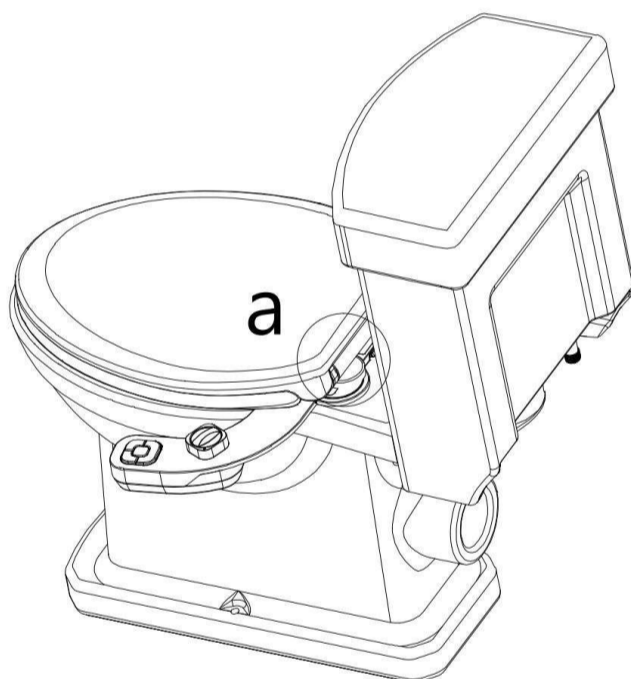
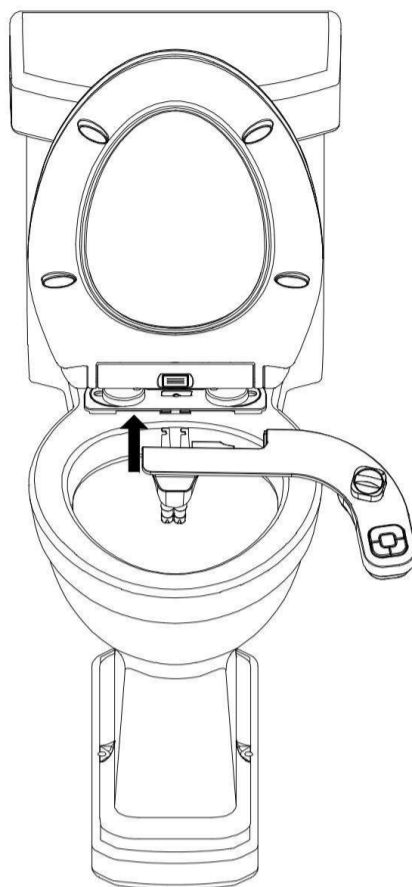

オペレーター指承グ



1. ボタンを使用してノズル機能を選択します。

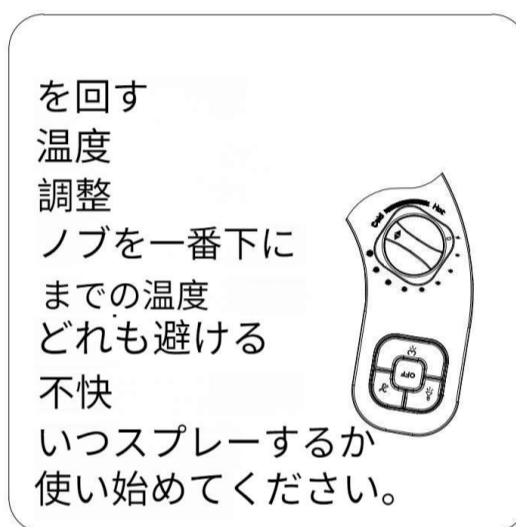
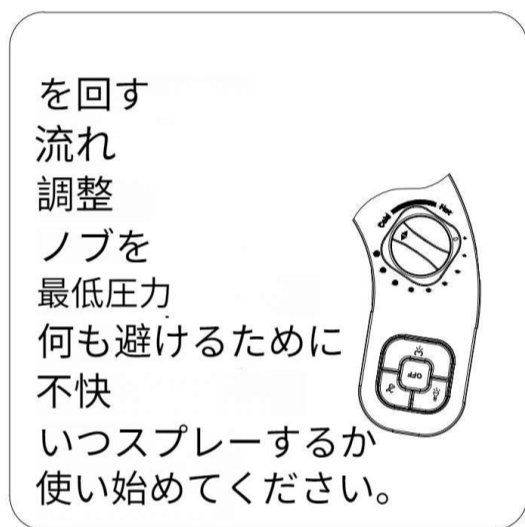

2. 水流を調整します。

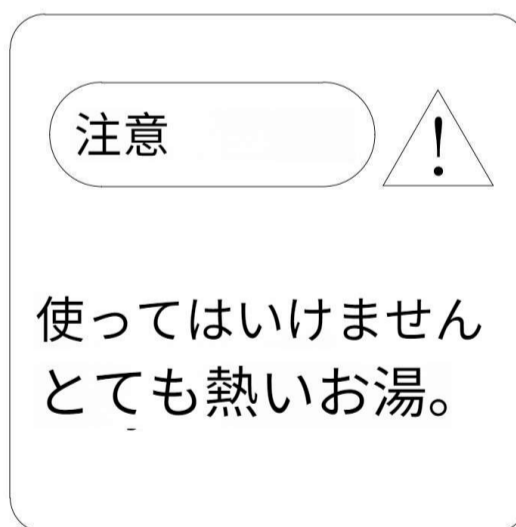

3. 必要なだけ使用してください。

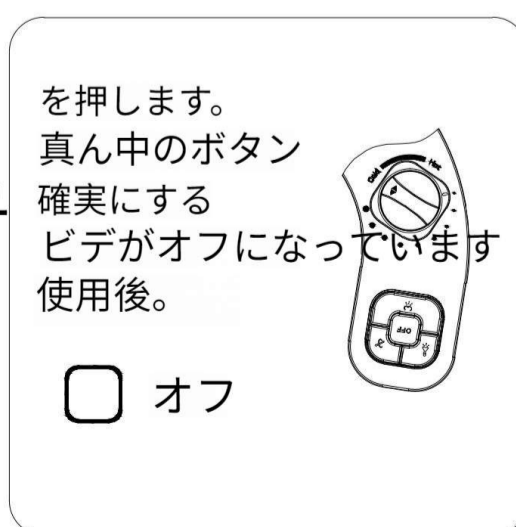

MANUALE DI ISTRUZIONI

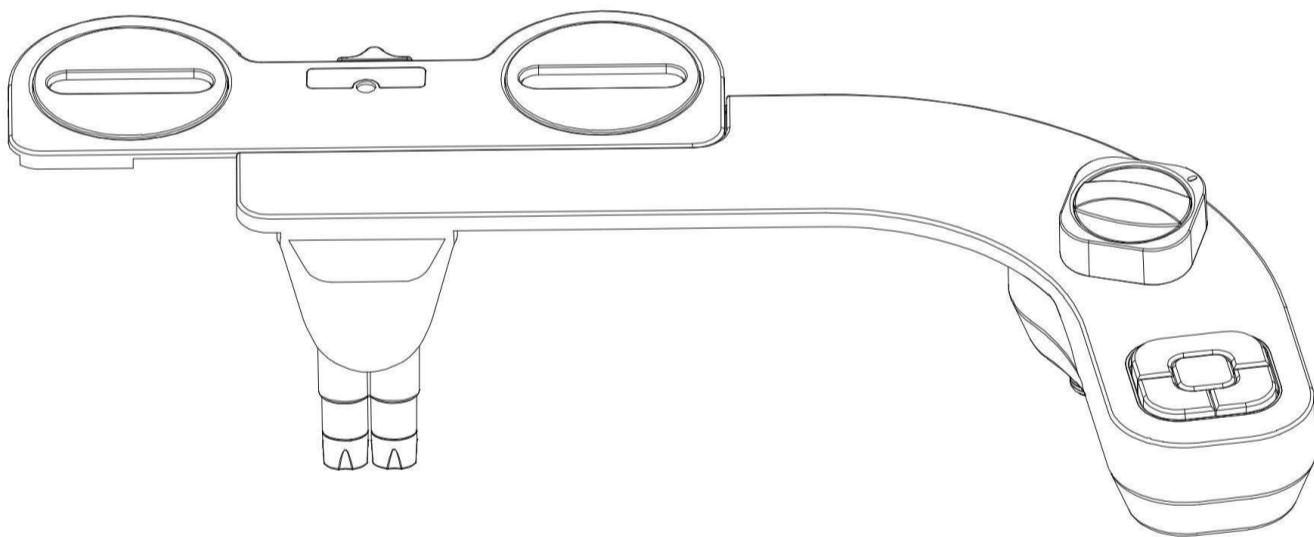

Nomi e funzioni delle parti

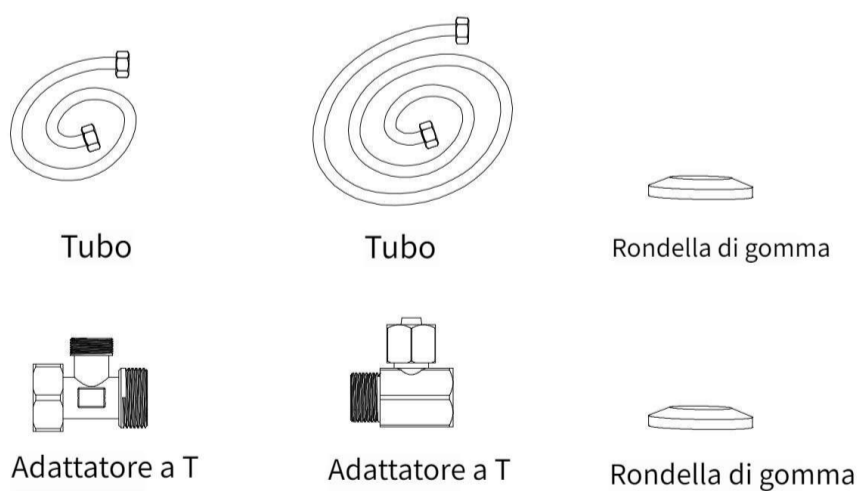
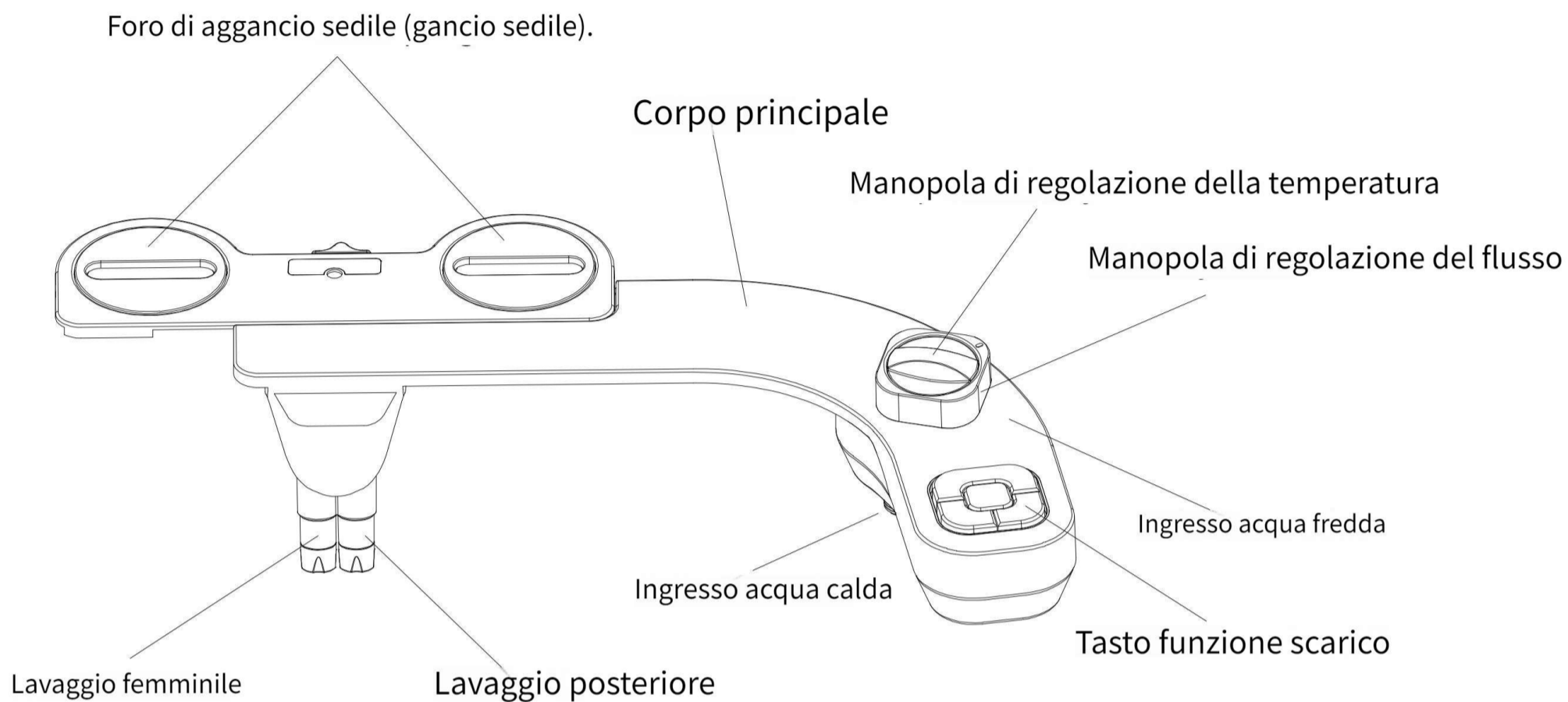

Installa il bidet

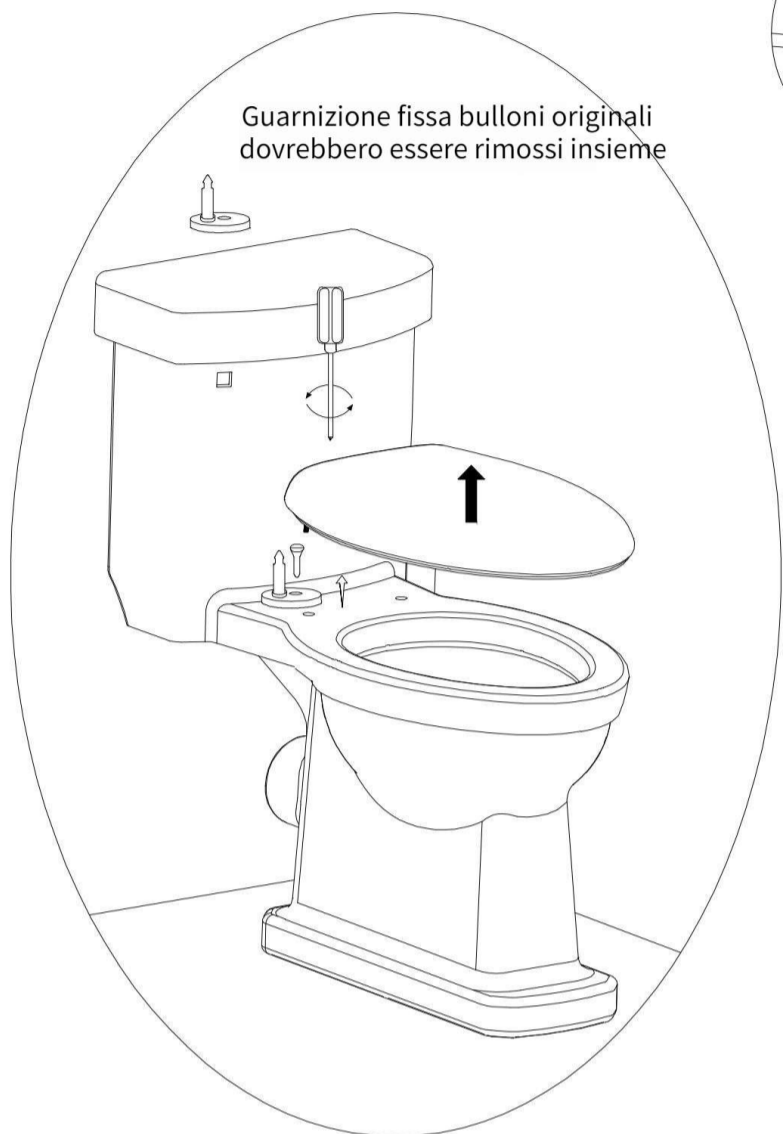

a

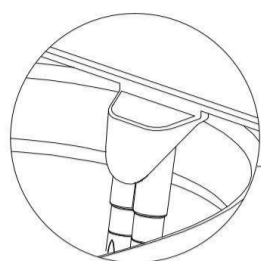

Regolare l'ugello posizione e prova a farlo avvicinato al bordo del WC.

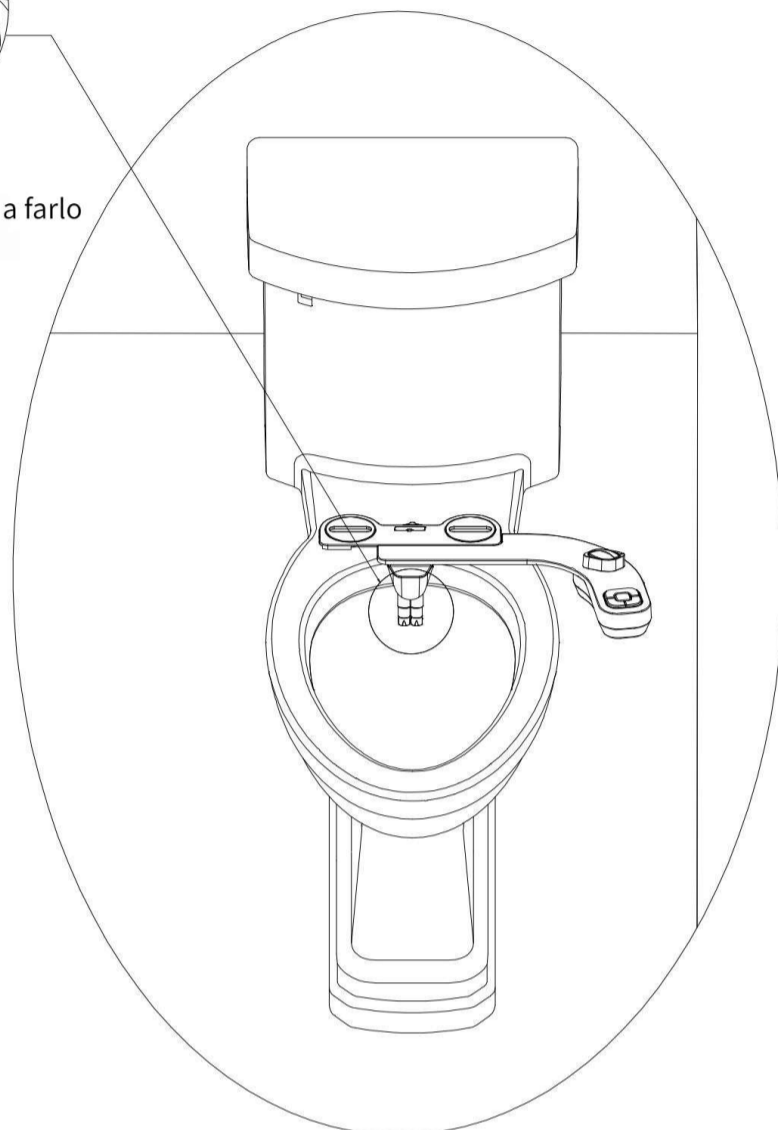

b

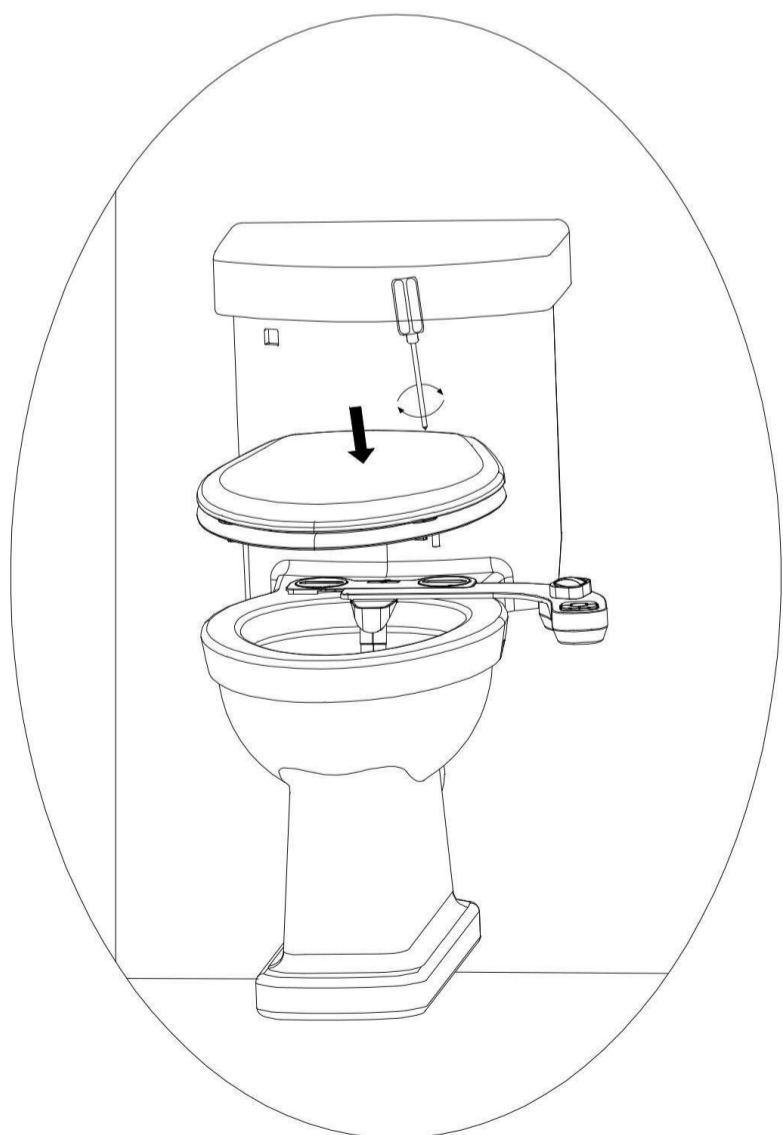

c

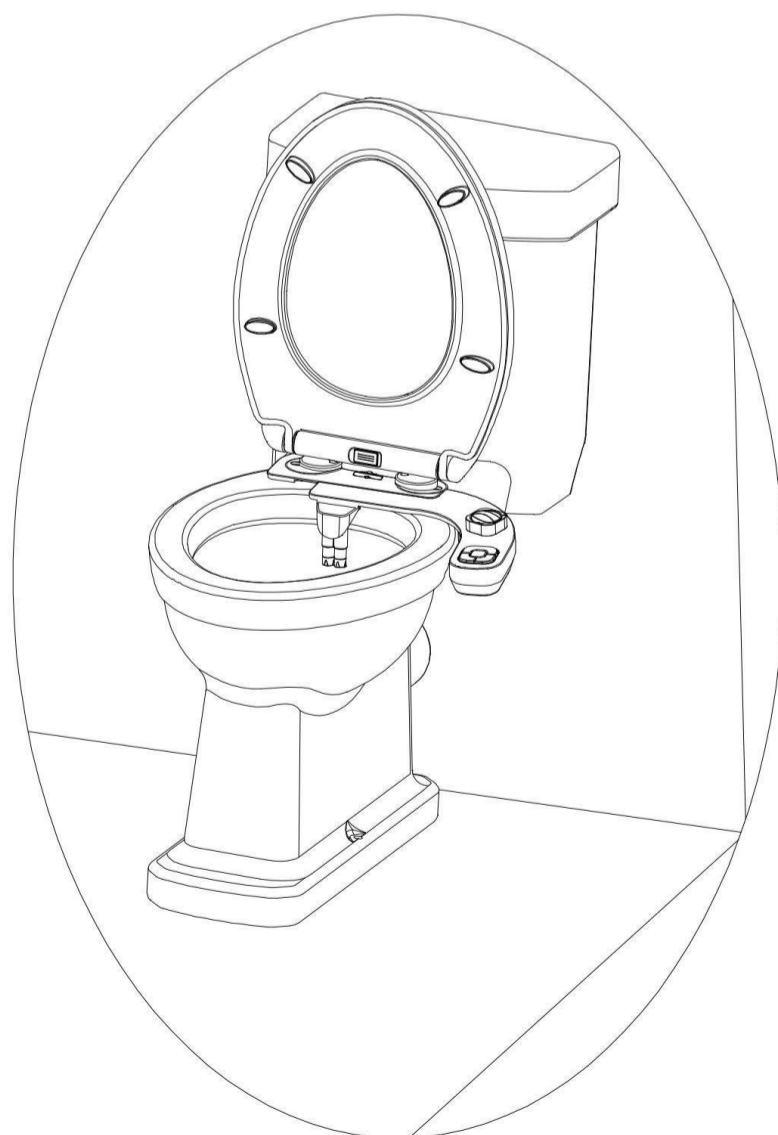

d

Collegare l'acqua fredda

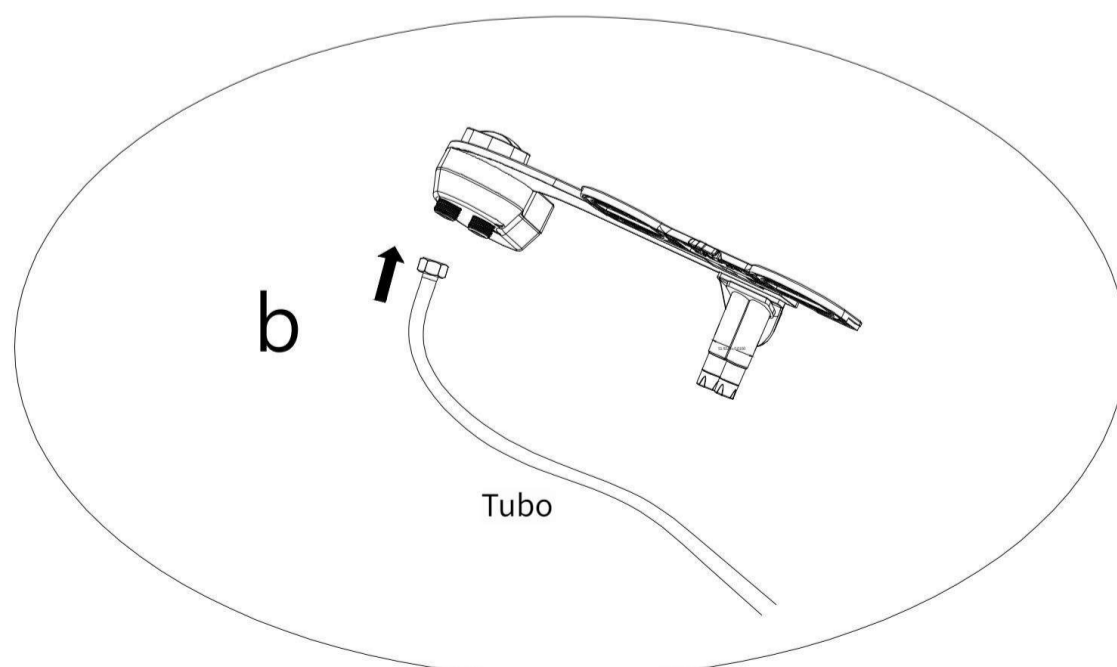
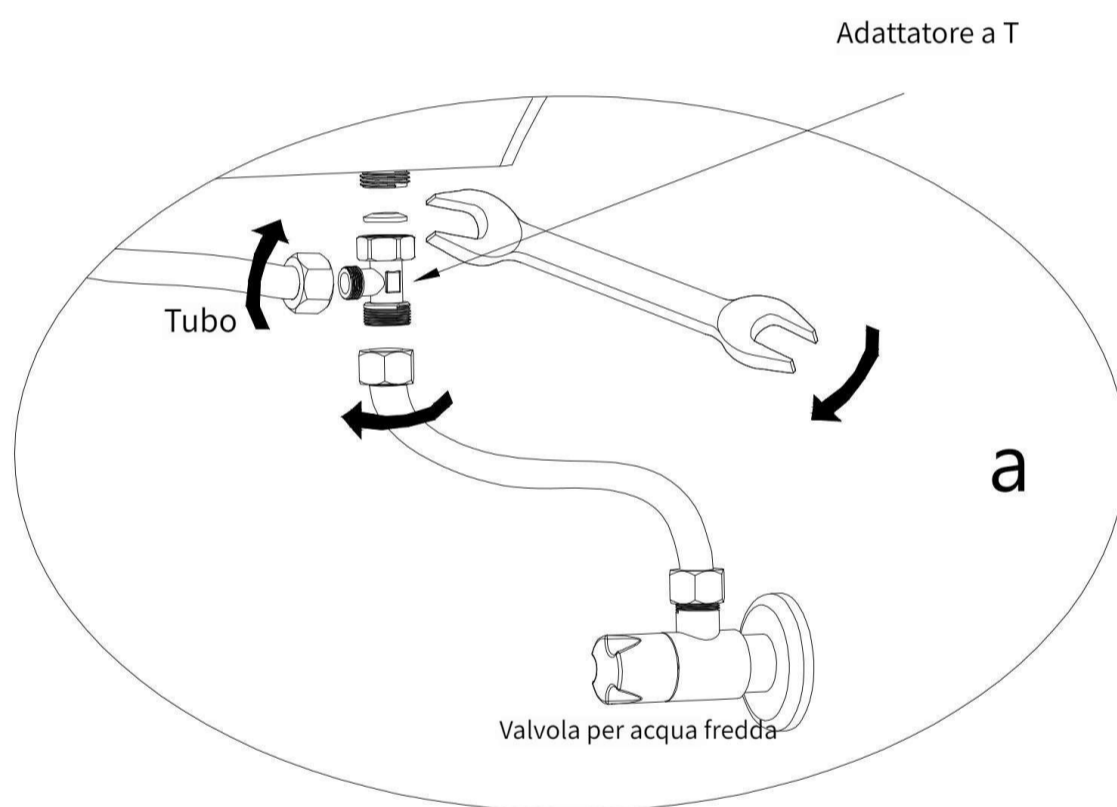
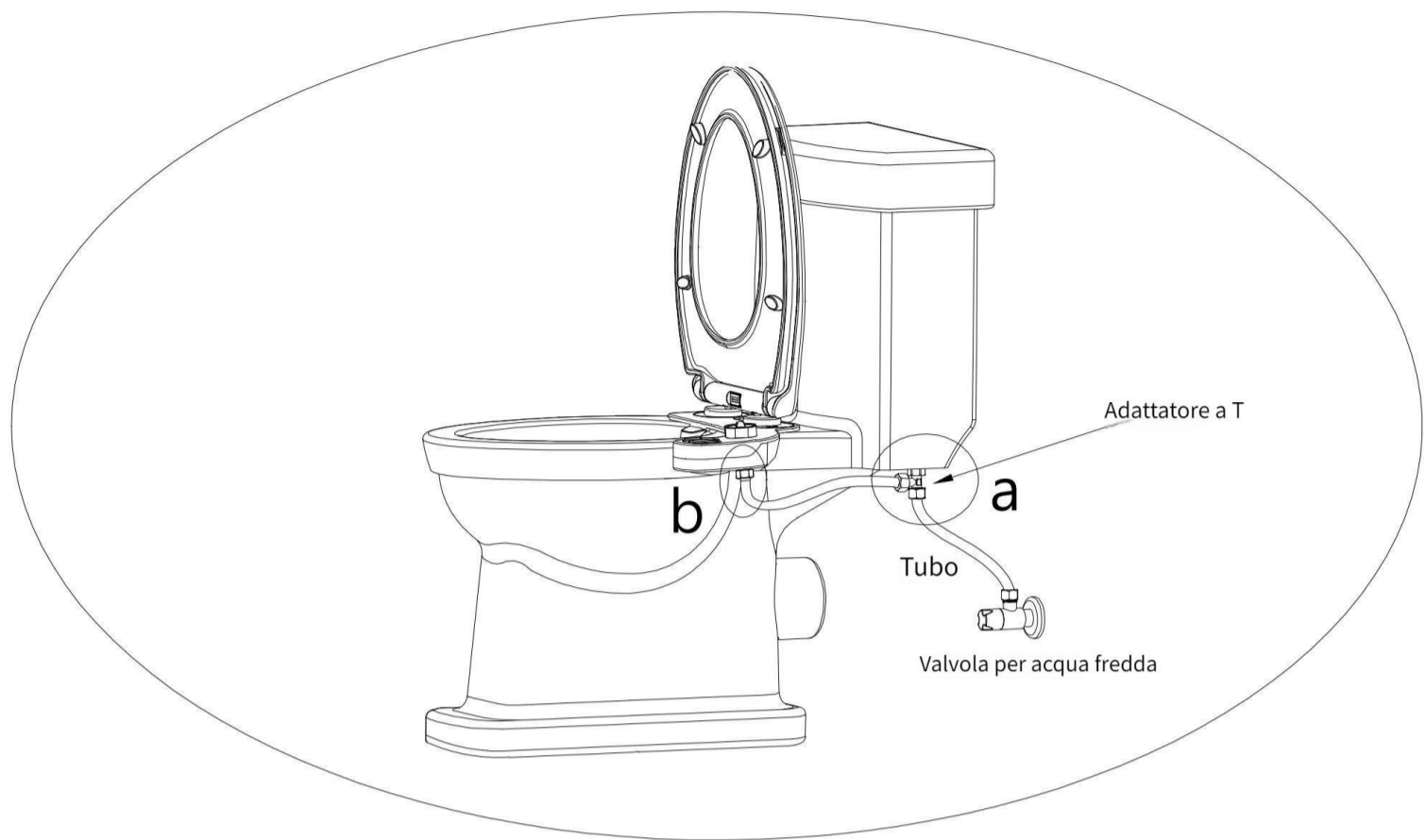

Collegare l'acqua calda

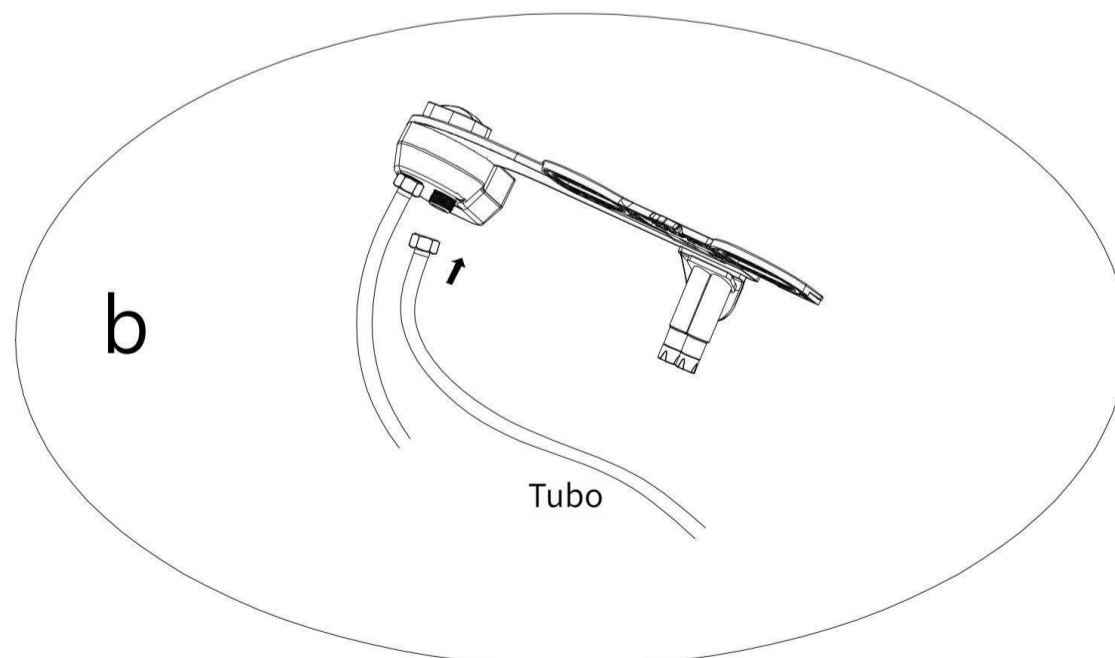
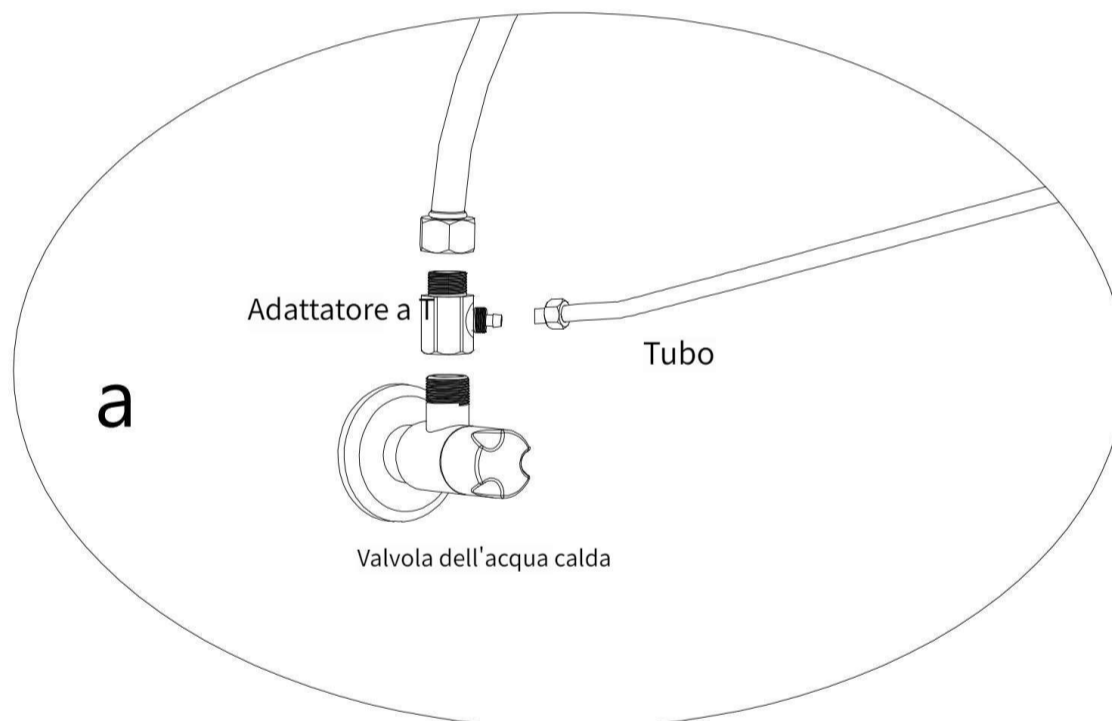
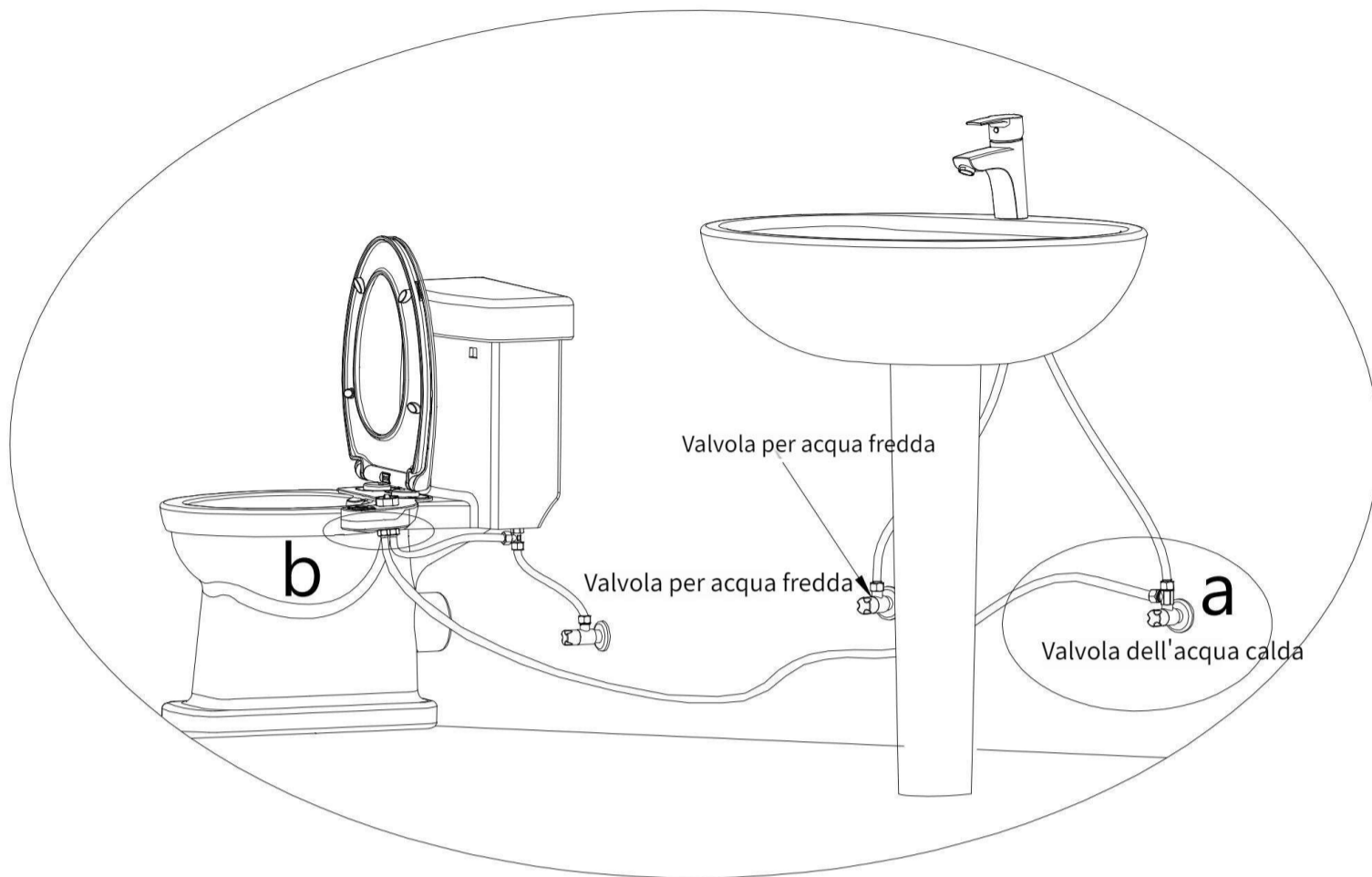

Rilascio rapido

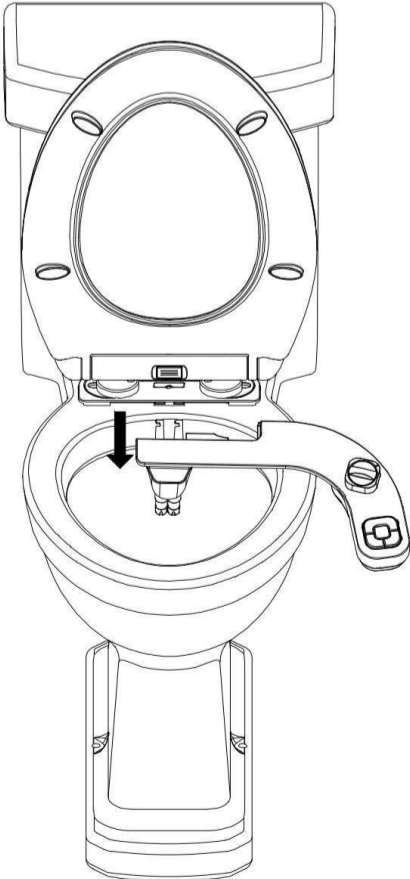
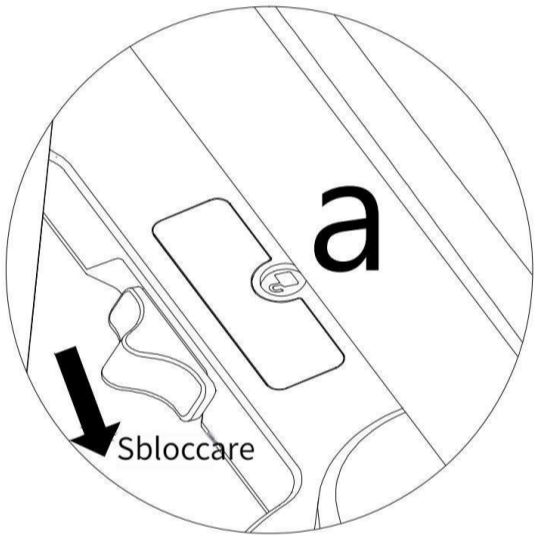
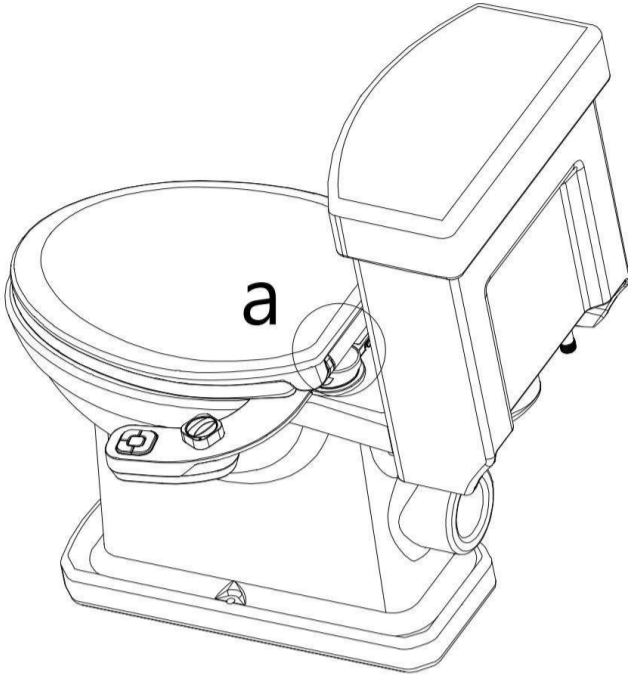

Installazione veloce

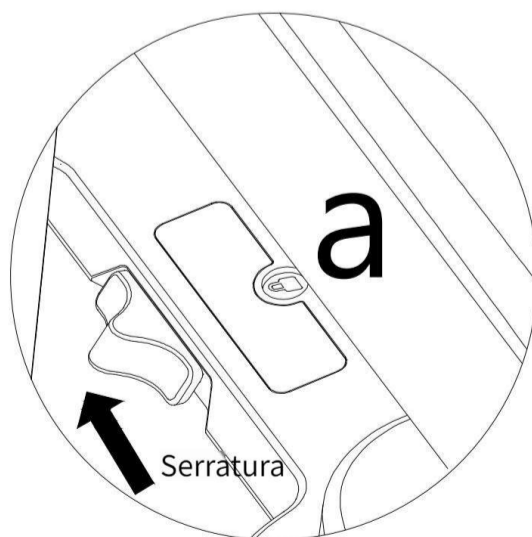
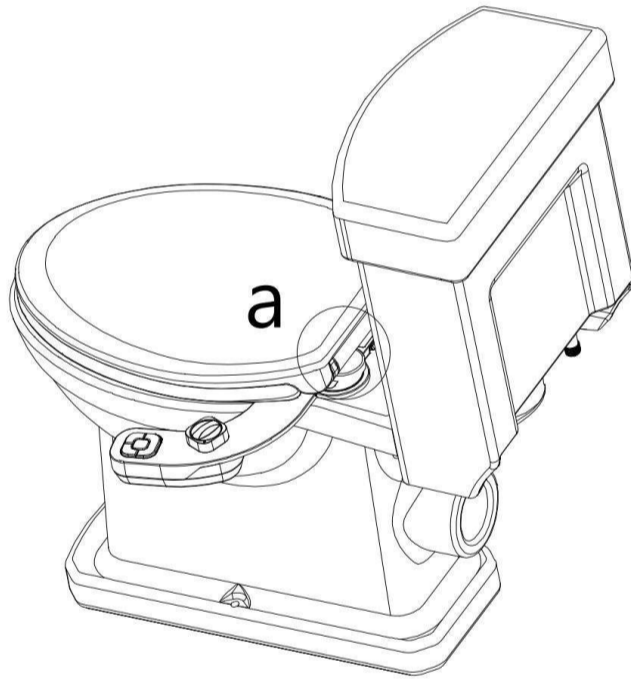
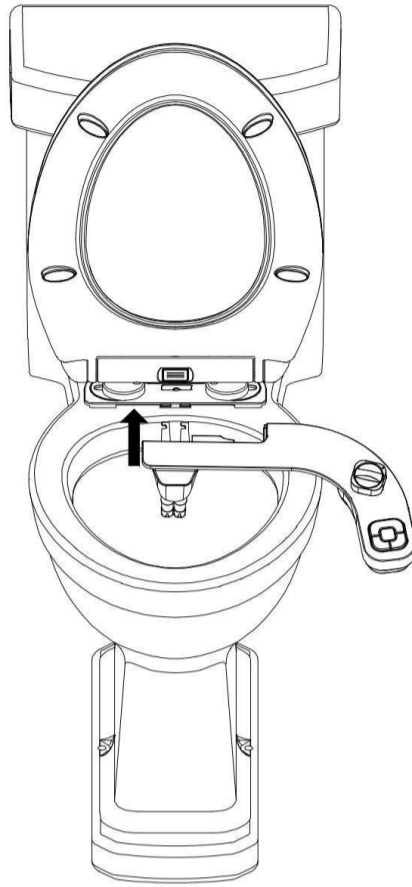

Operativo Istruzioni



1. Selezionare la funzione dell'ugello utilizzando il pulsante.

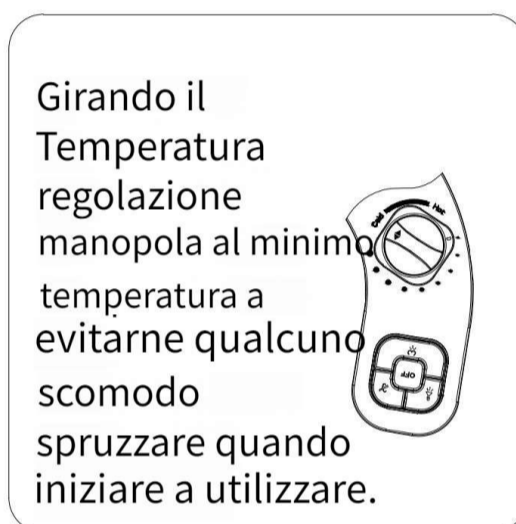
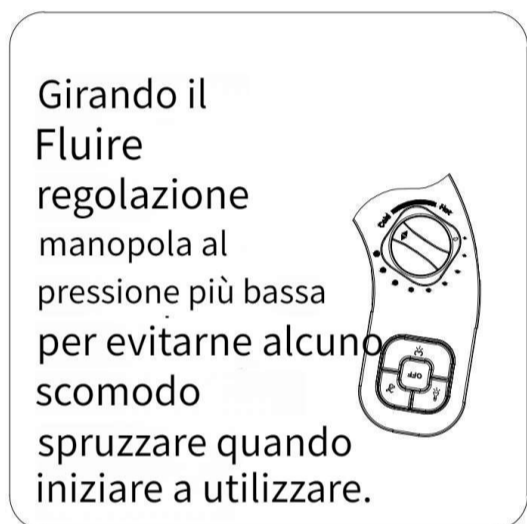

2. Regolare il flusso d'acqua.

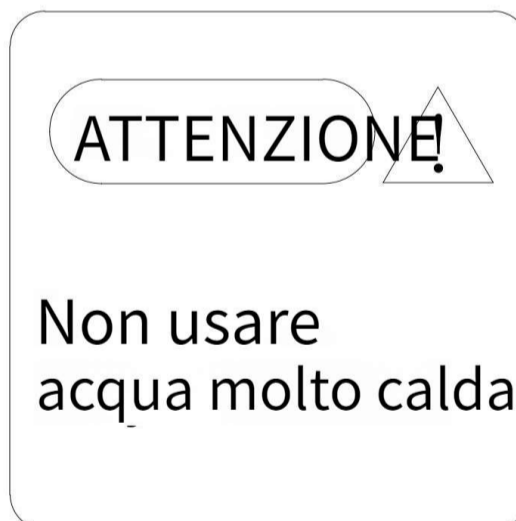

3. Utilizzare per tutto il tempo necessario.



BRUKSANVISNING

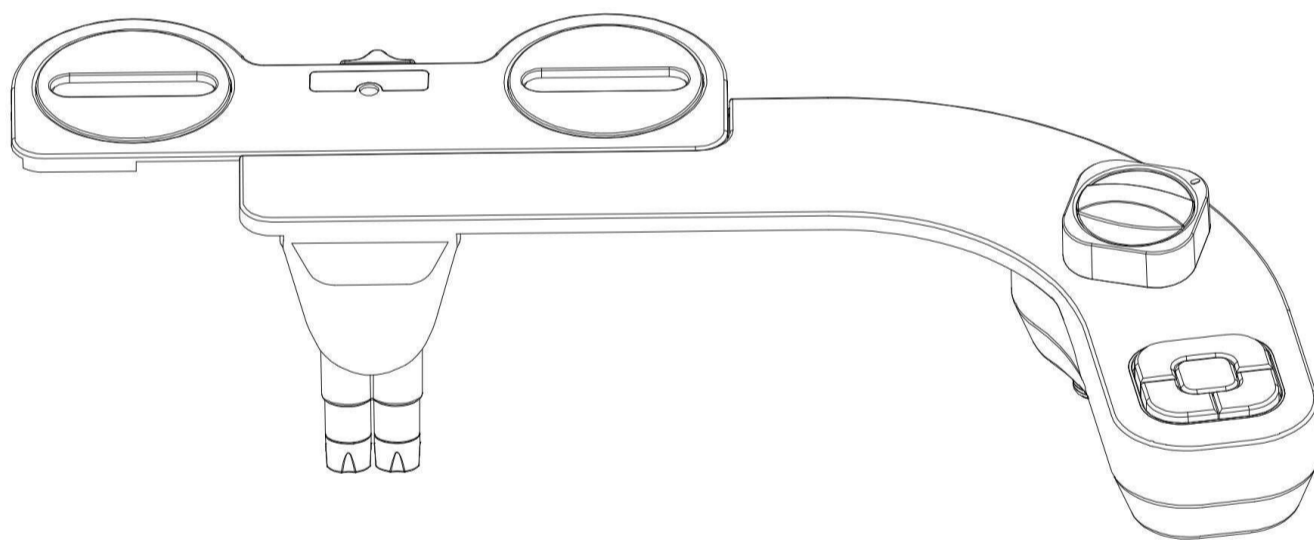

Delarnas namn och funktioner

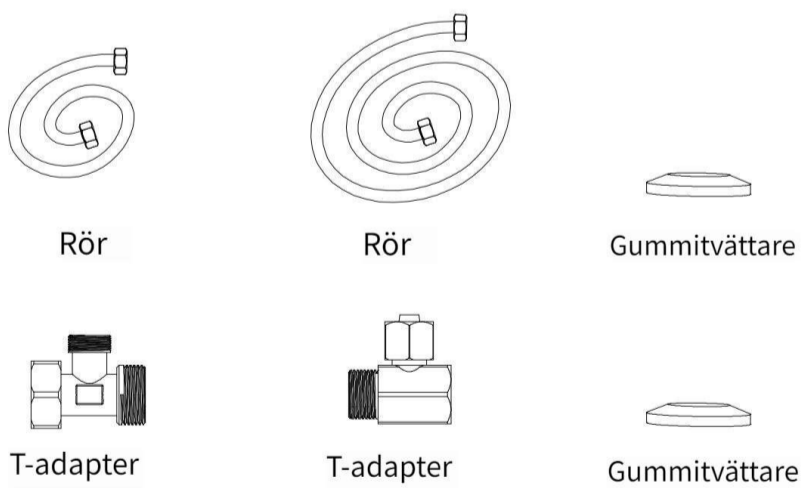
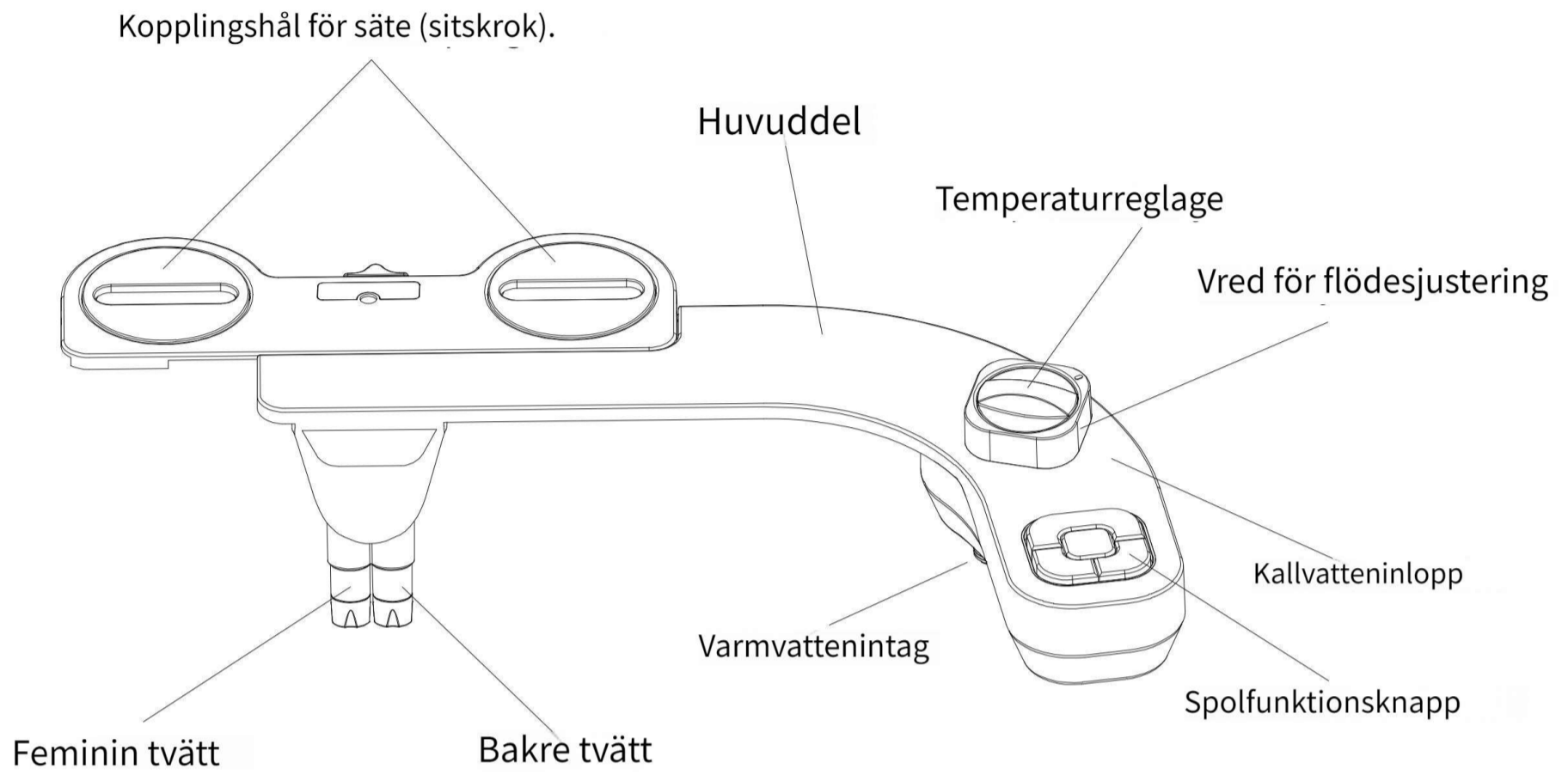

Installera Bidet

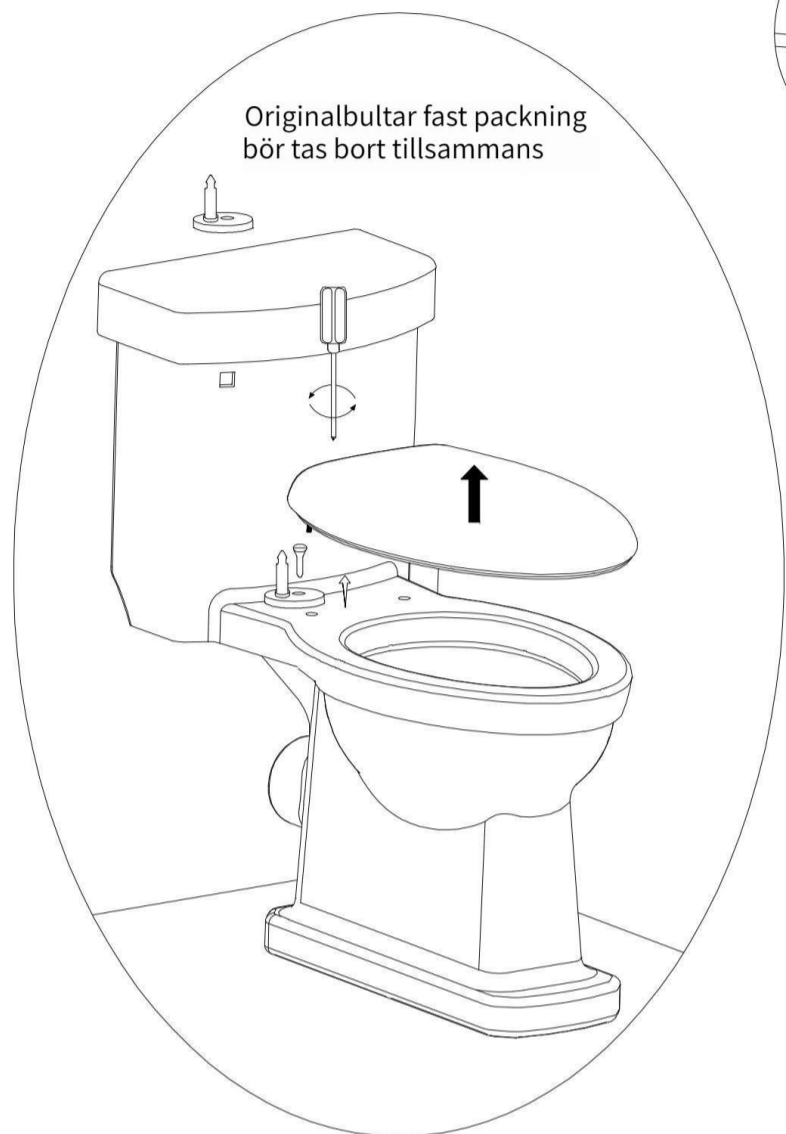

a

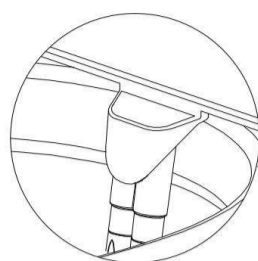

Justera munstycket position och försök att göra det nära kanten på toaletten.

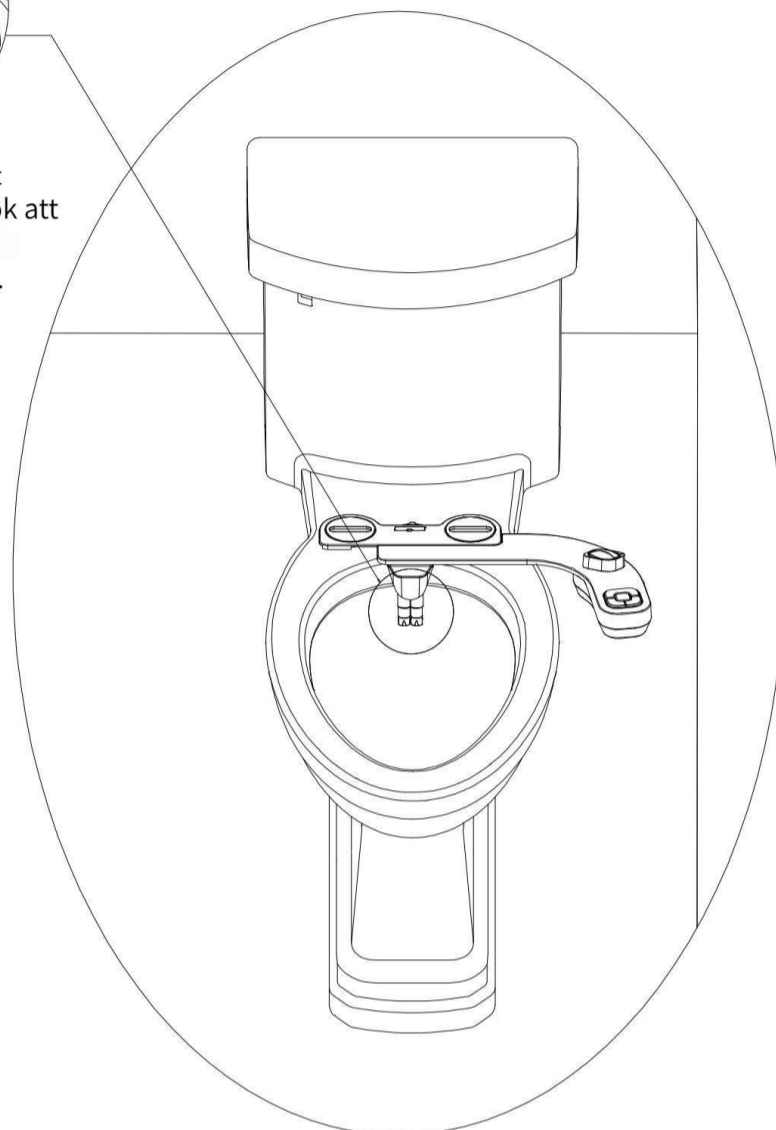

b

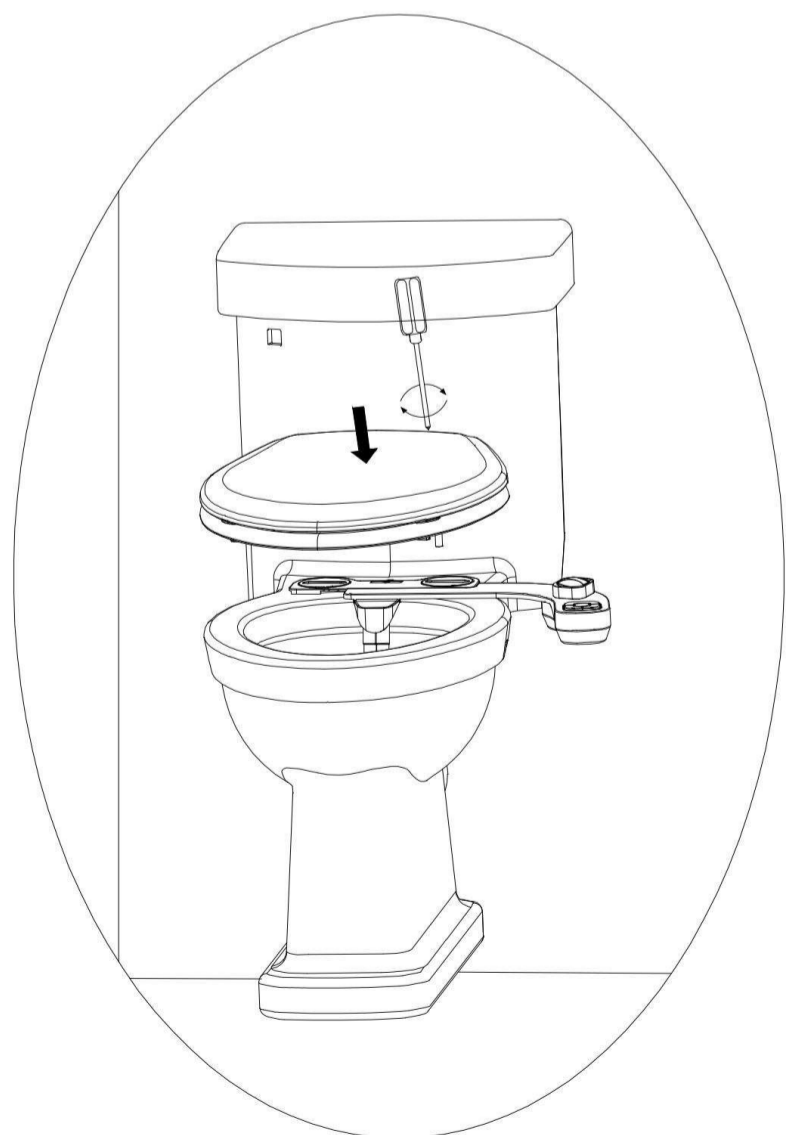

c



d

Anslut kallt vatten

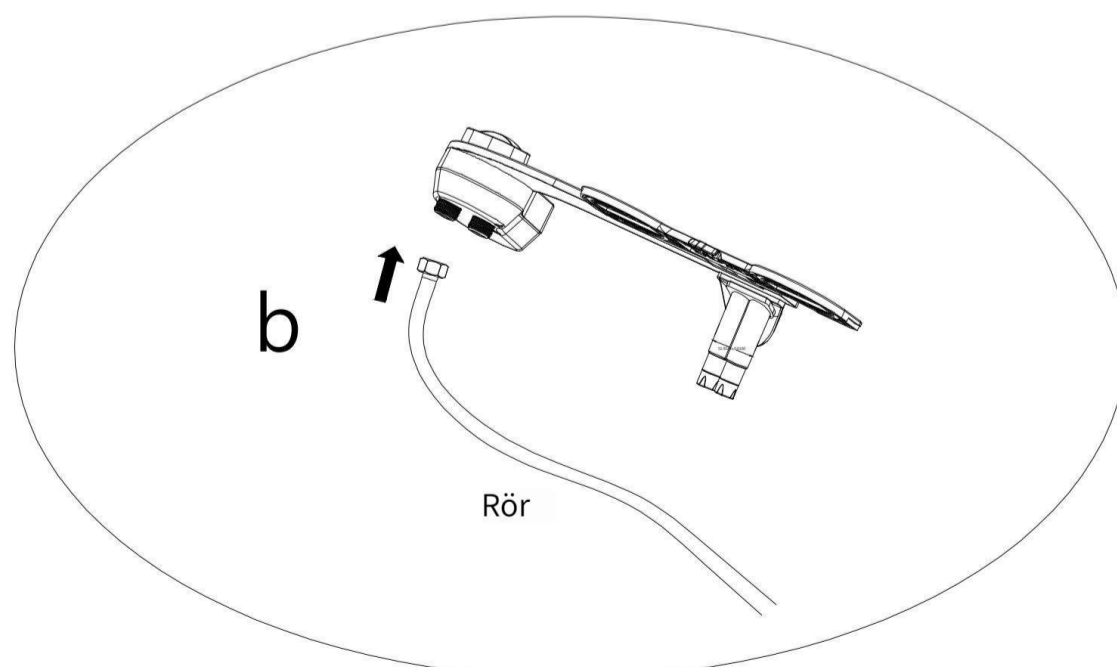
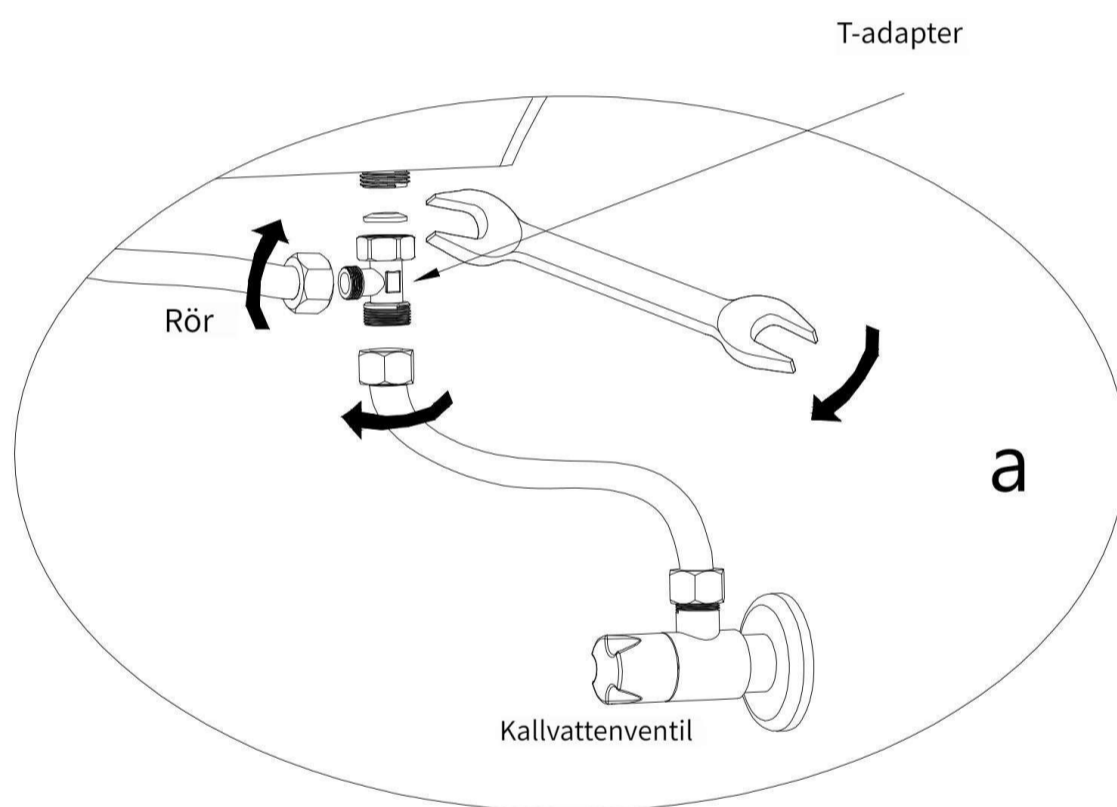
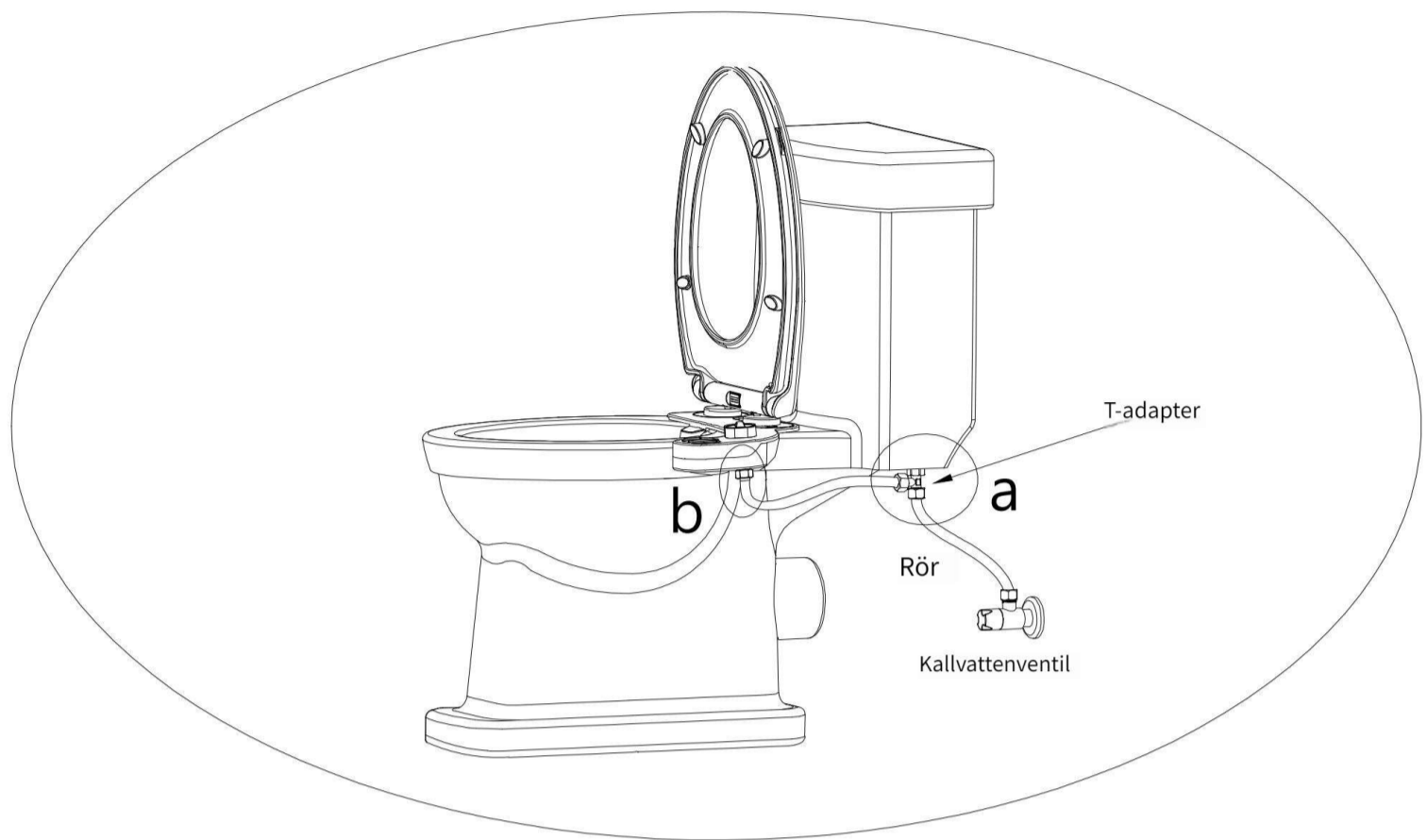

Anslut varmvatten

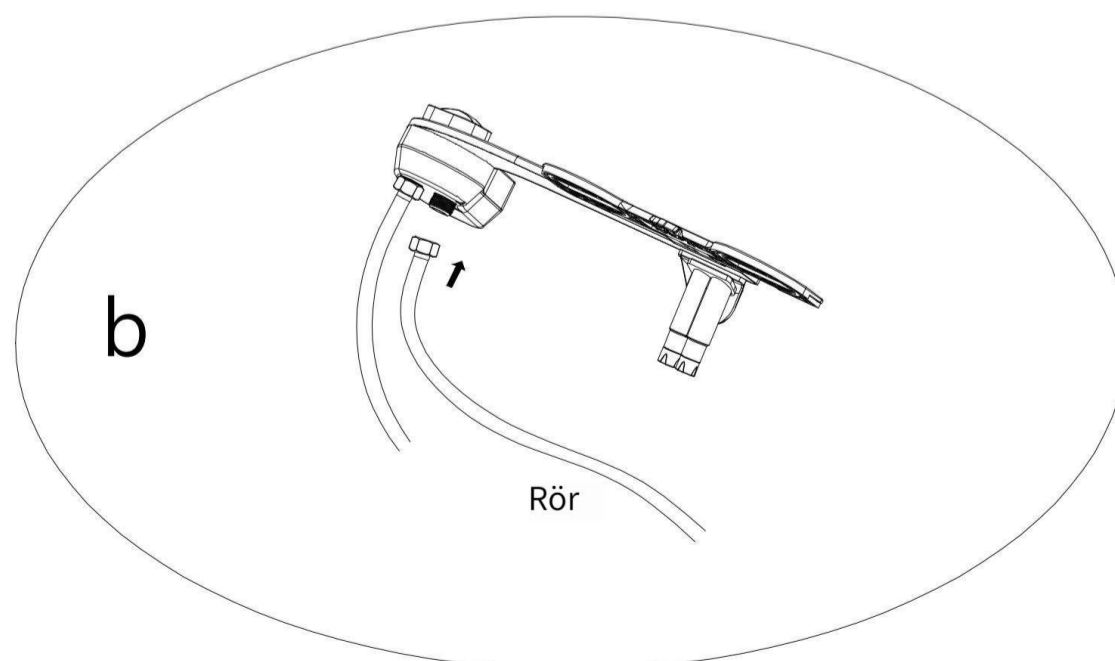
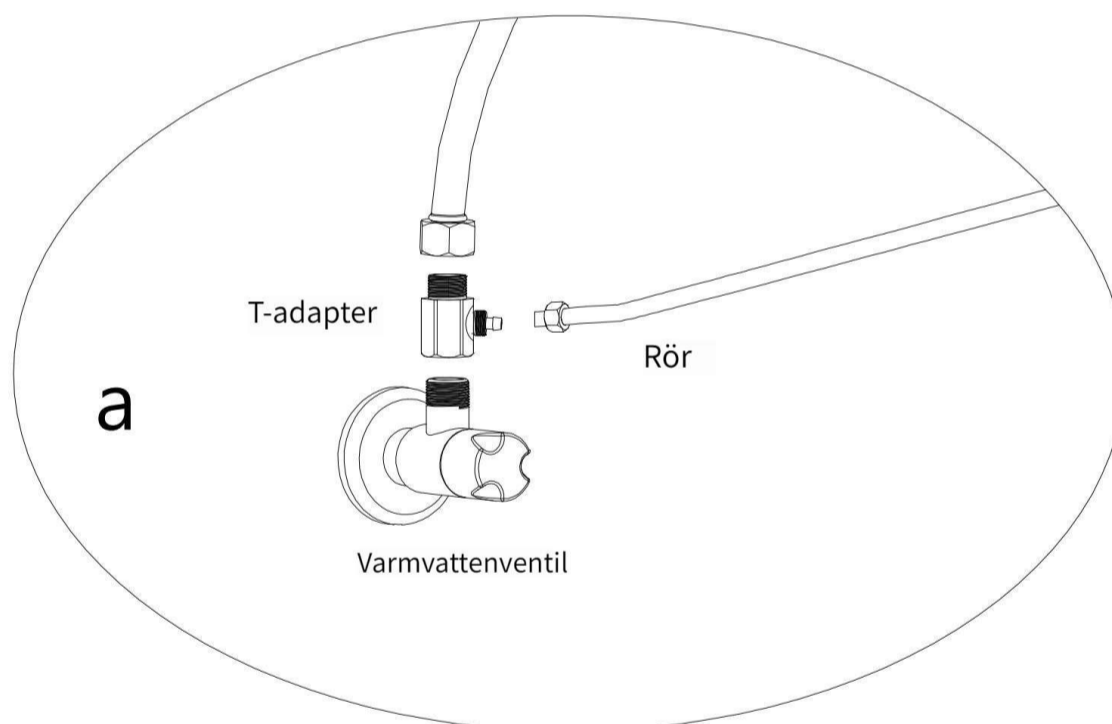
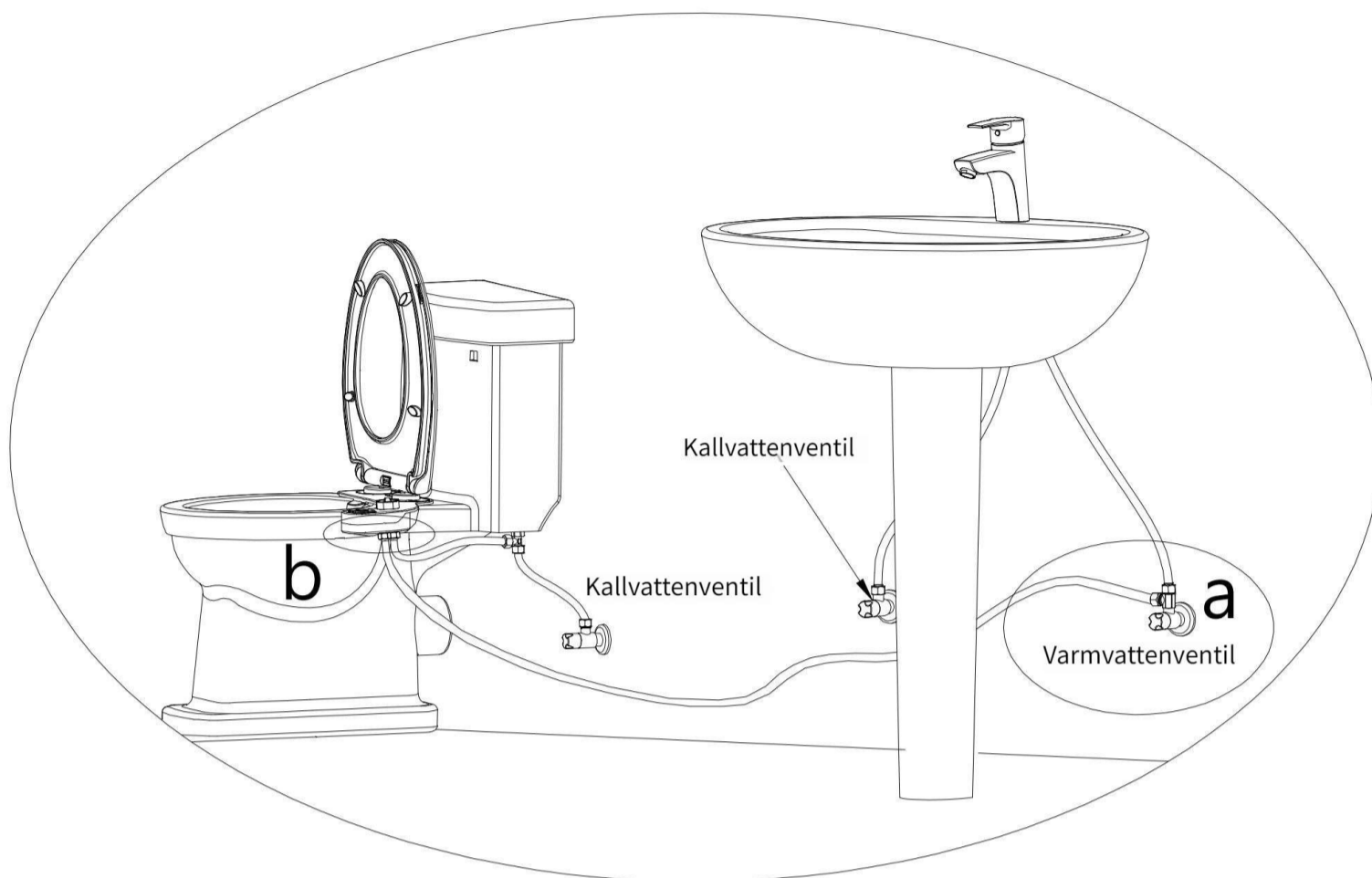

Snabbsläpp

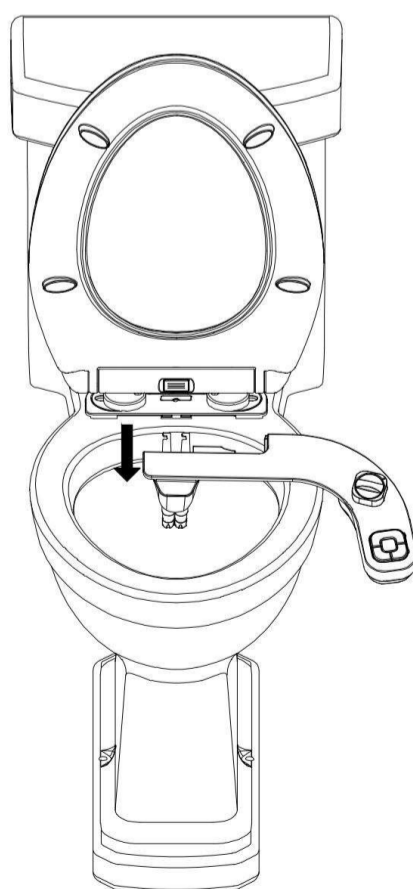
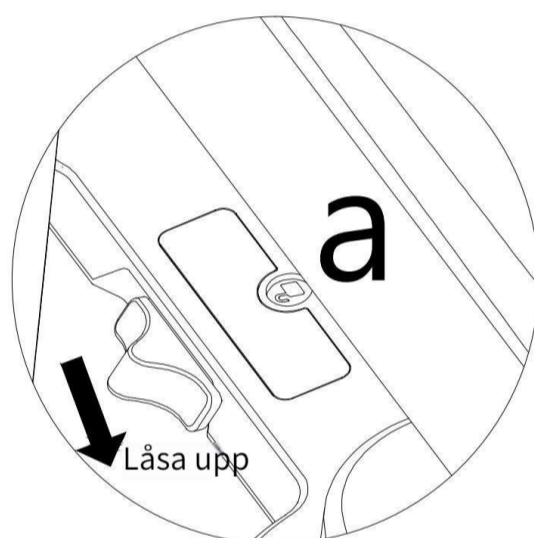
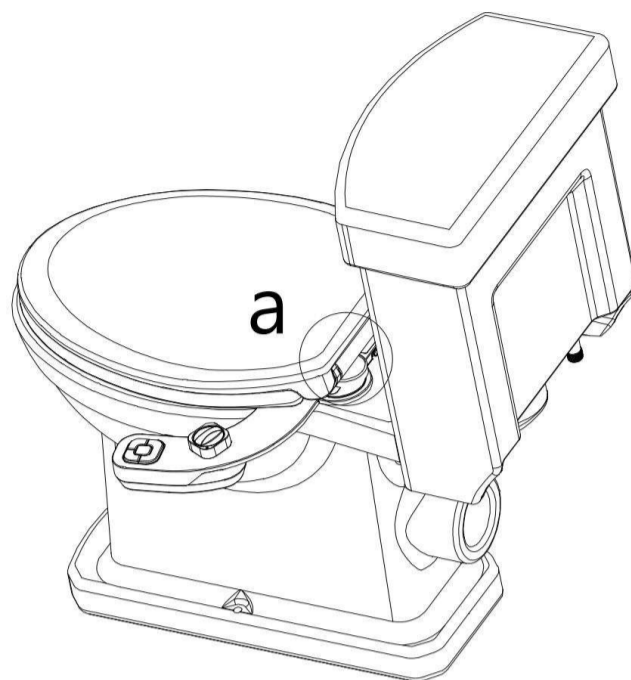

Snabb installation

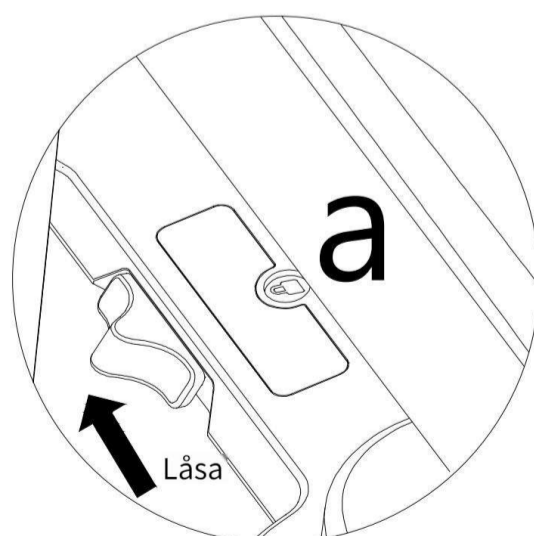
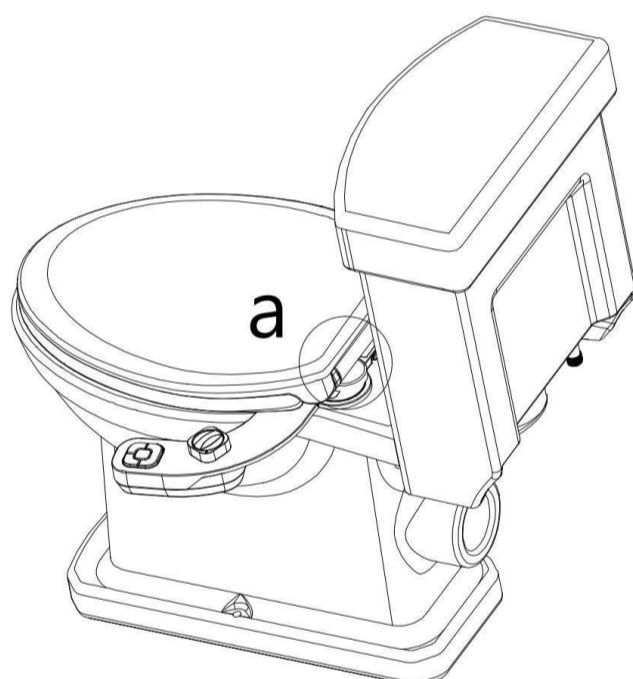
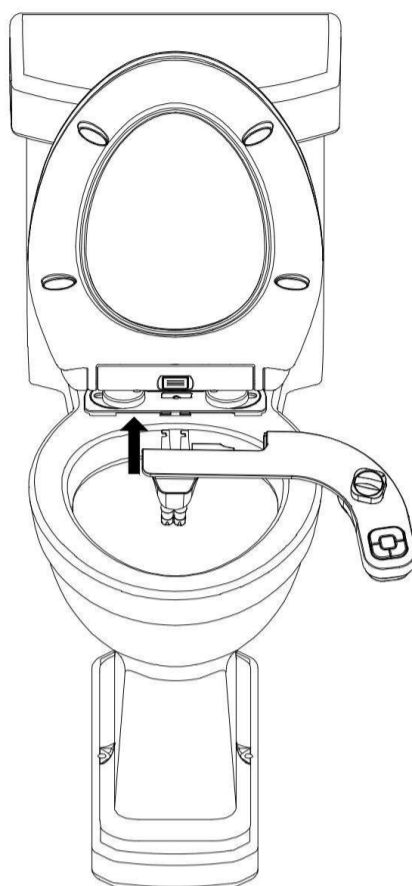

Drift

Anvisningar



1. Välj munstycksfunktion med knappen.

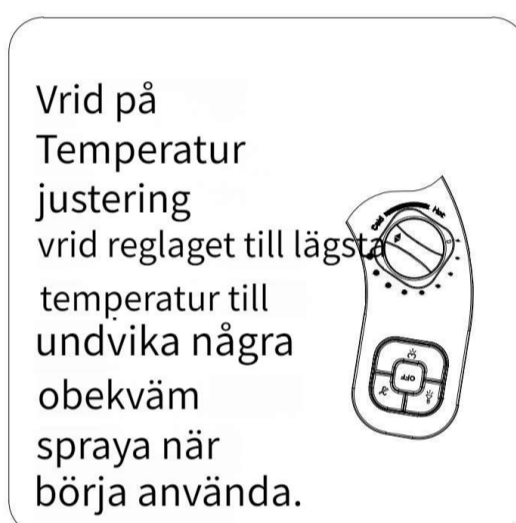
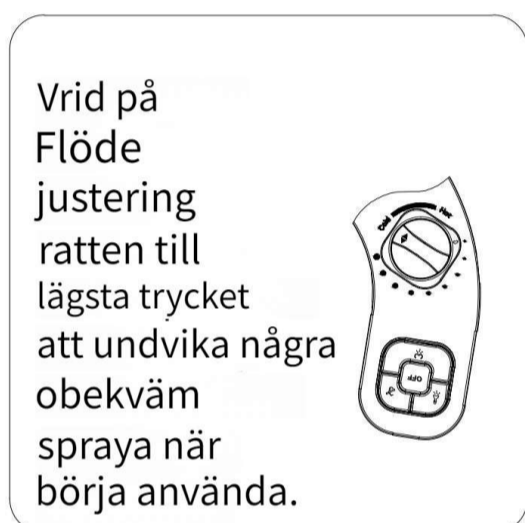

2. Justera vattenflödet.



3. Använd så länge som behövs.



NÁVOD K POUZÍMÍ

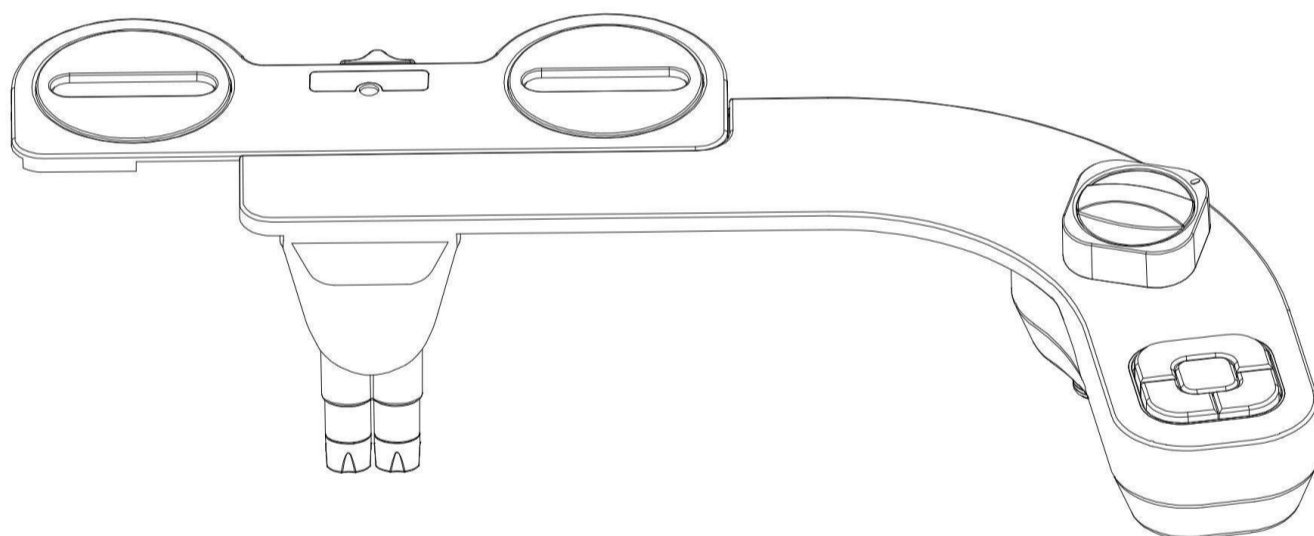

Názvy A Funkce Částí

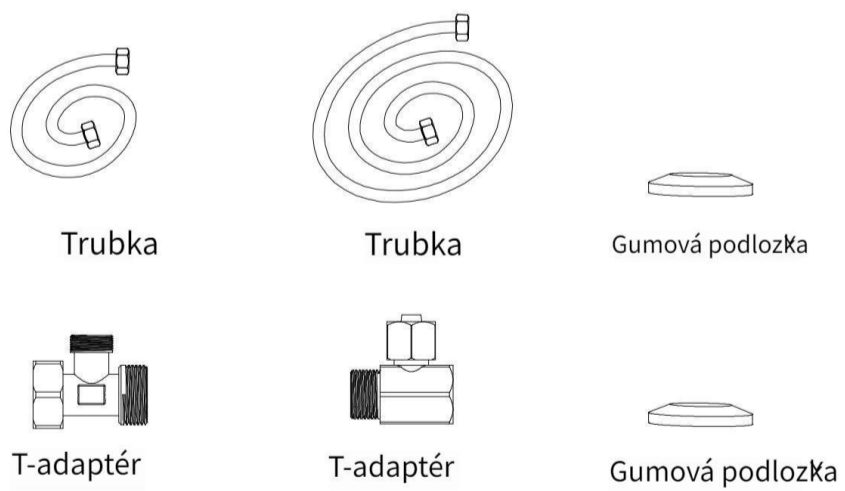
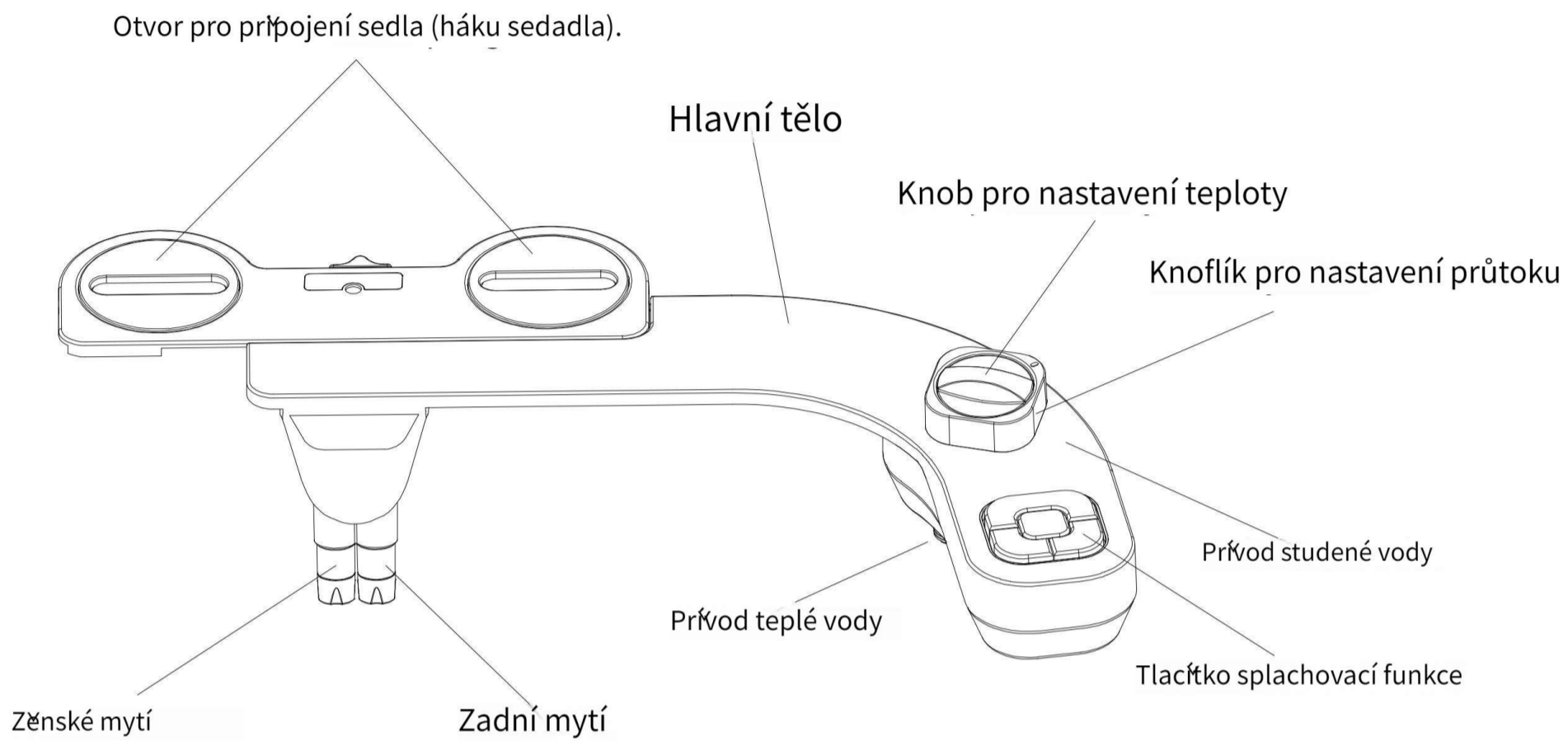

Nainstalujte Bidet

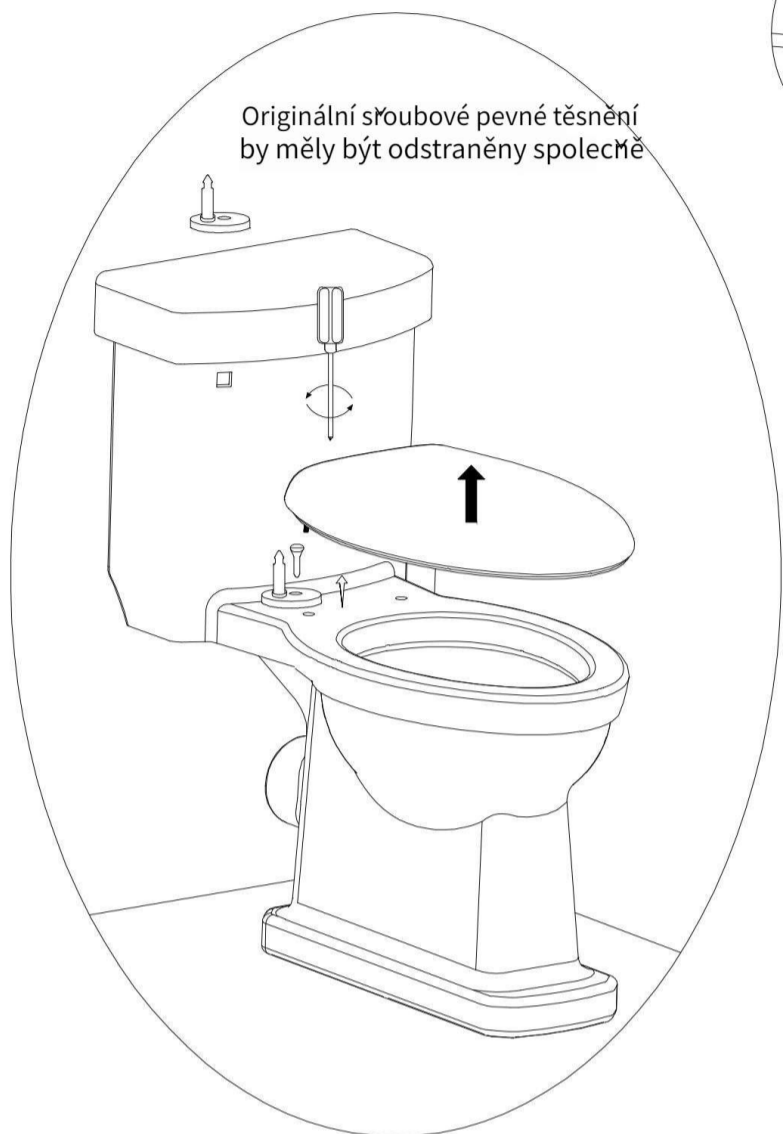

a

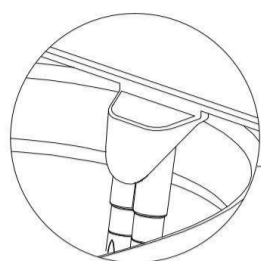

Nastavte trysku pozici a pokusit se o to aby to bylo blízko k okraj toalety.

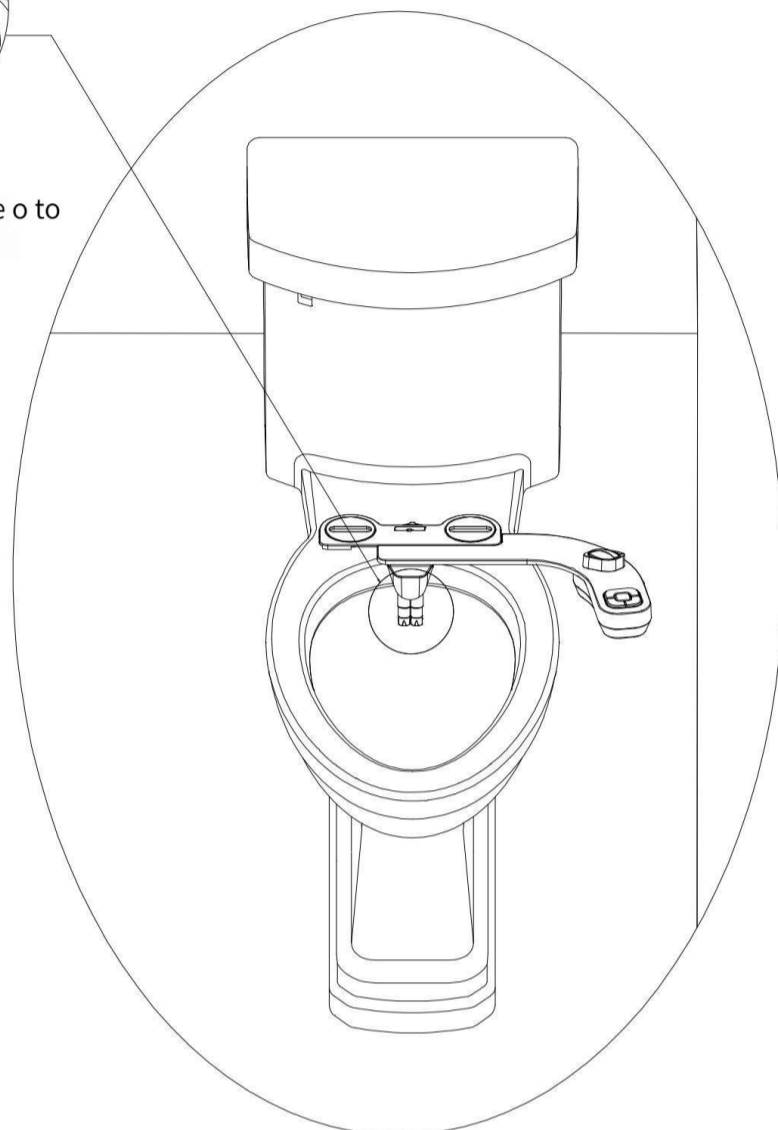

b

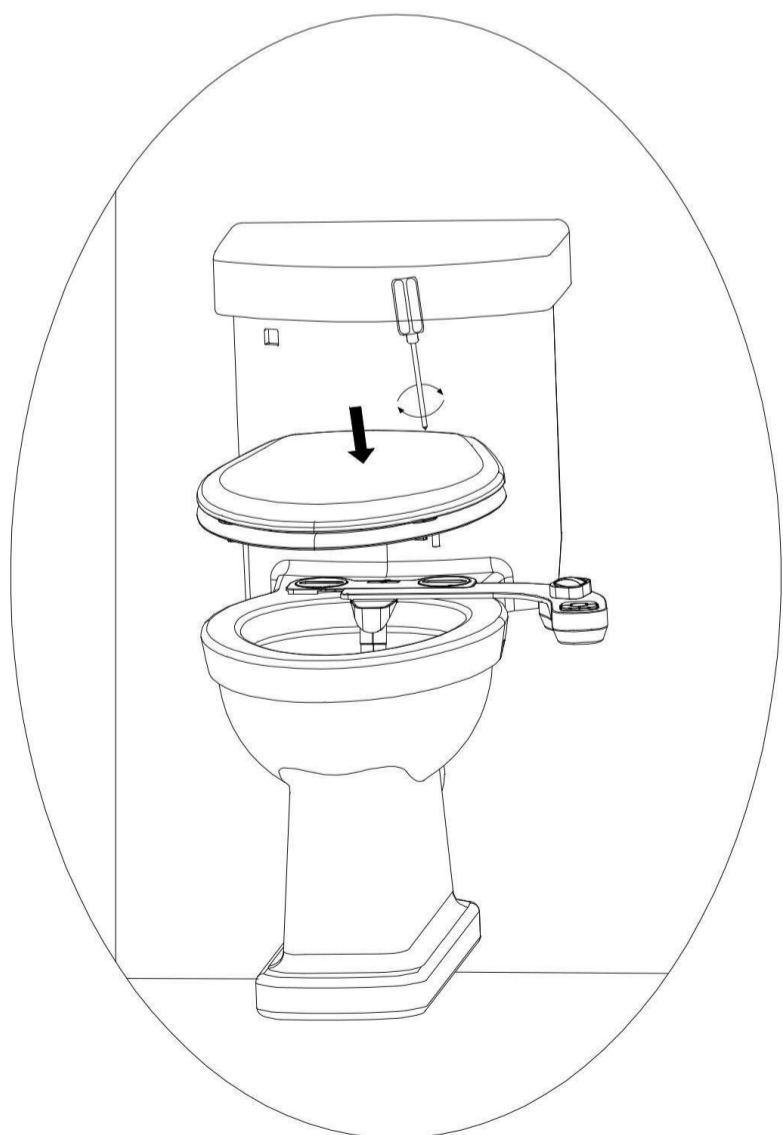

c

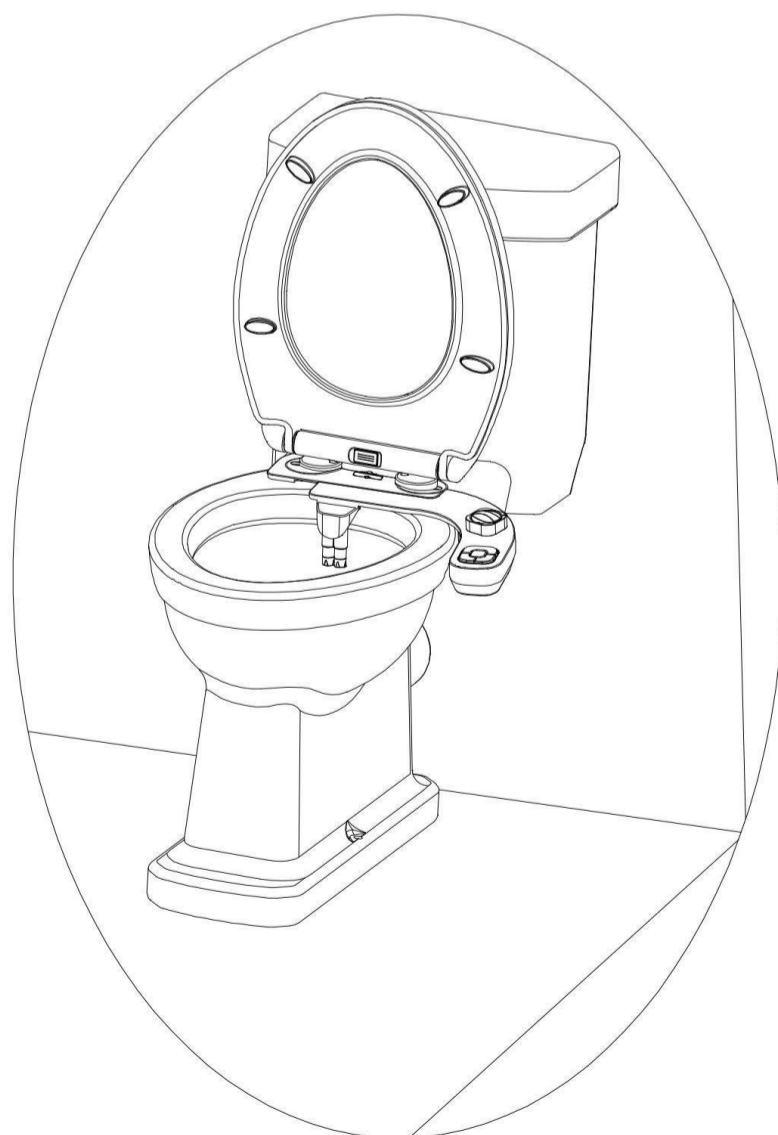

d

Prípojte studenou vodu

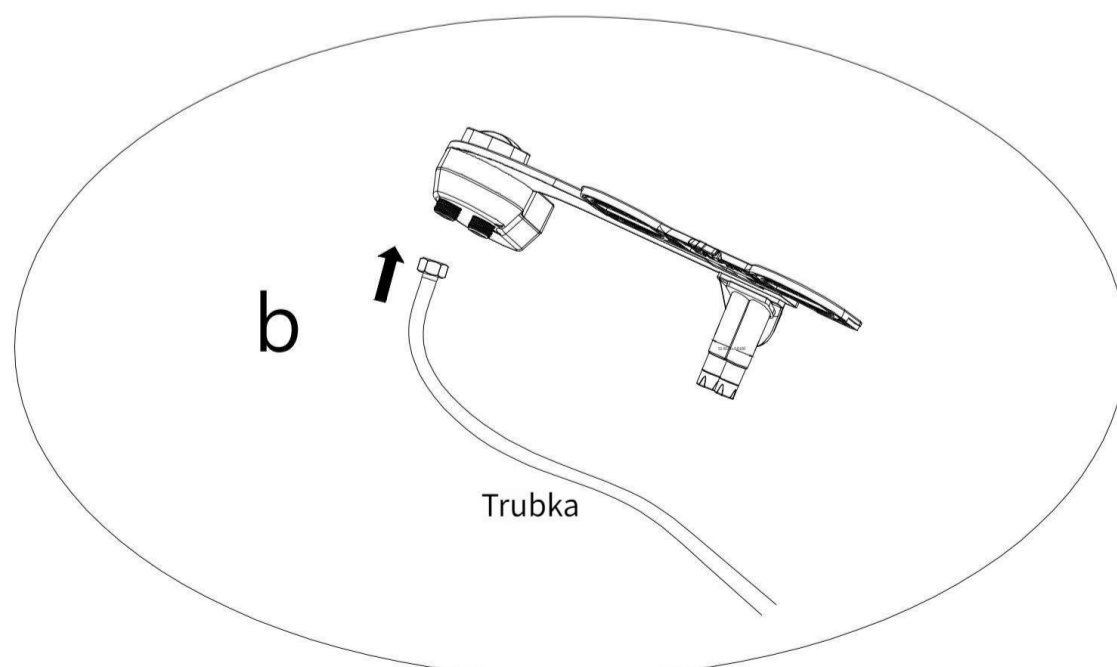
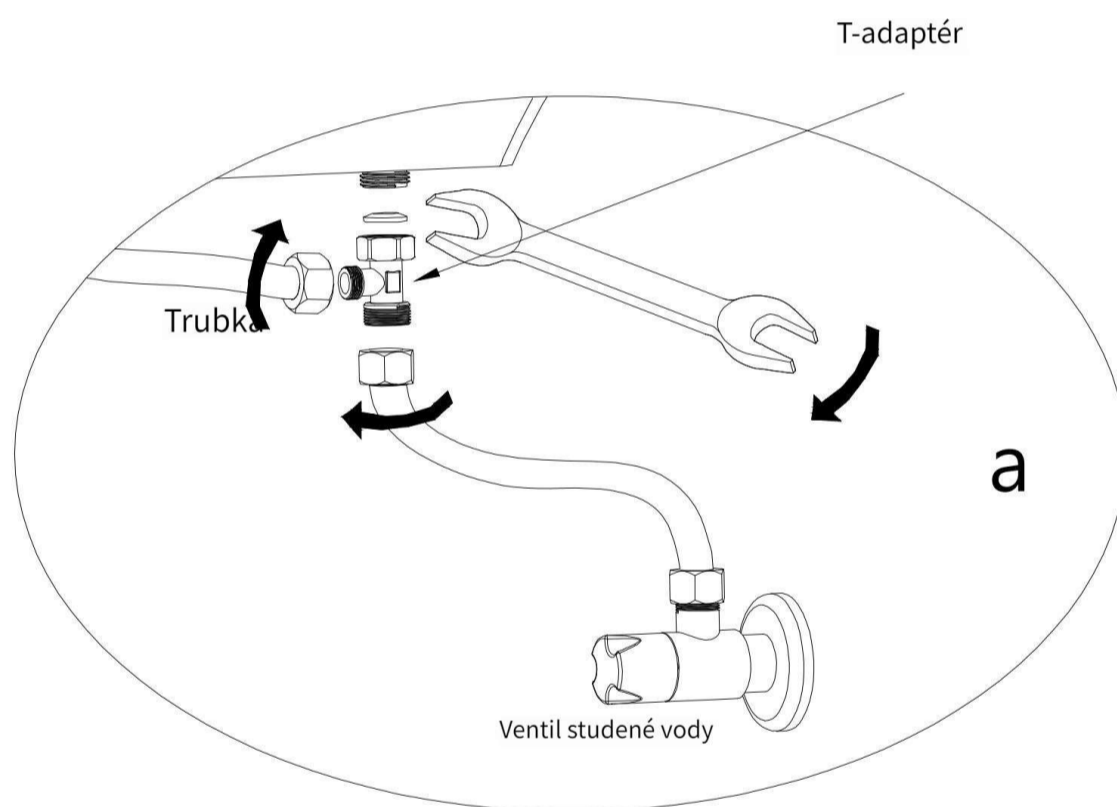
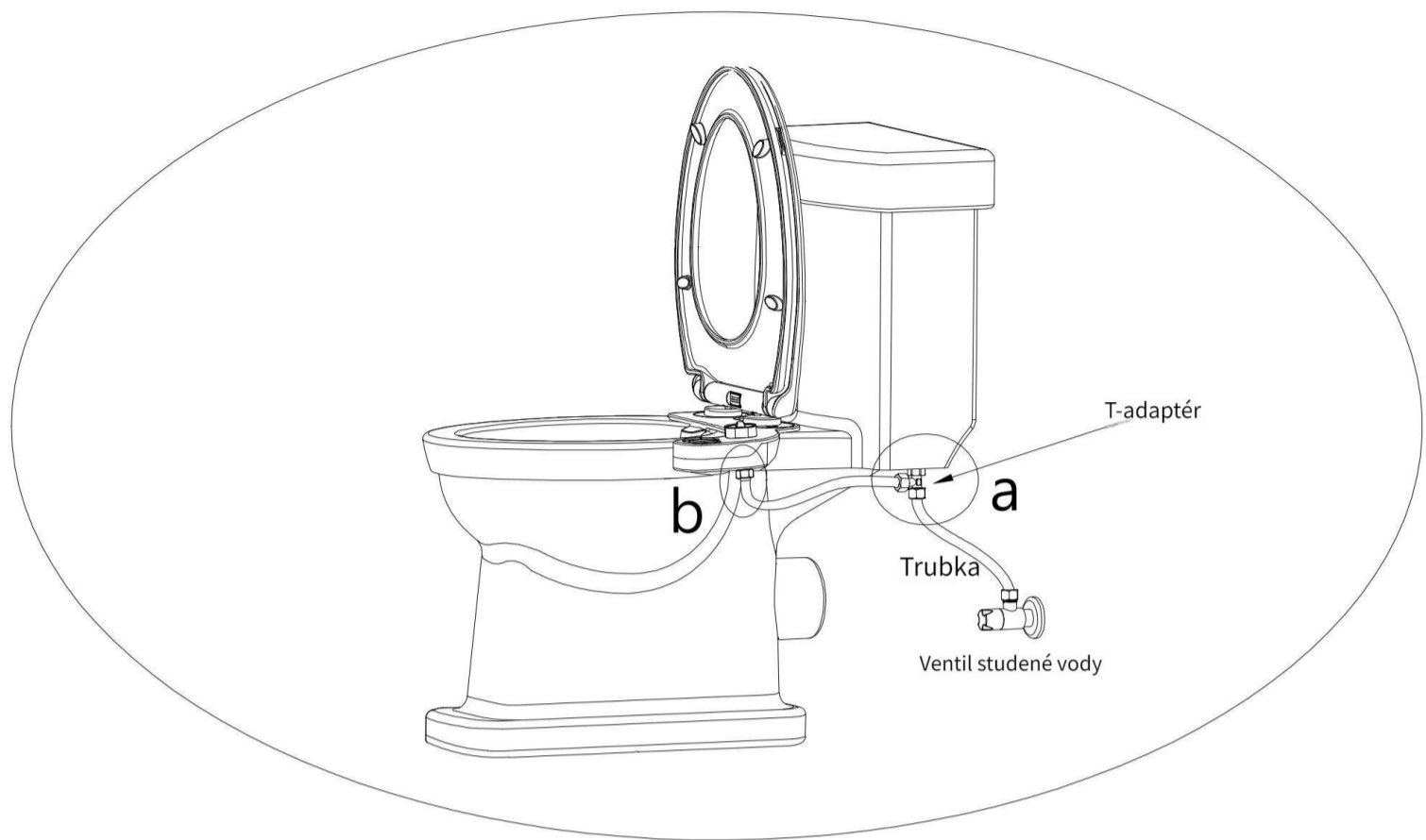

Prípojte teplou vodu

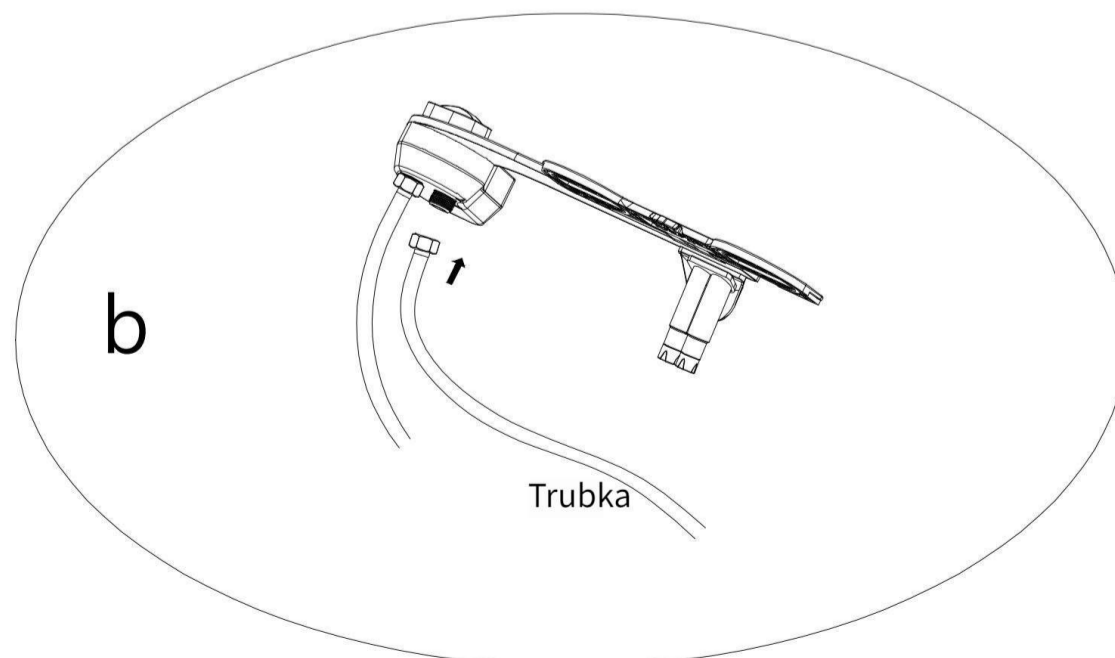
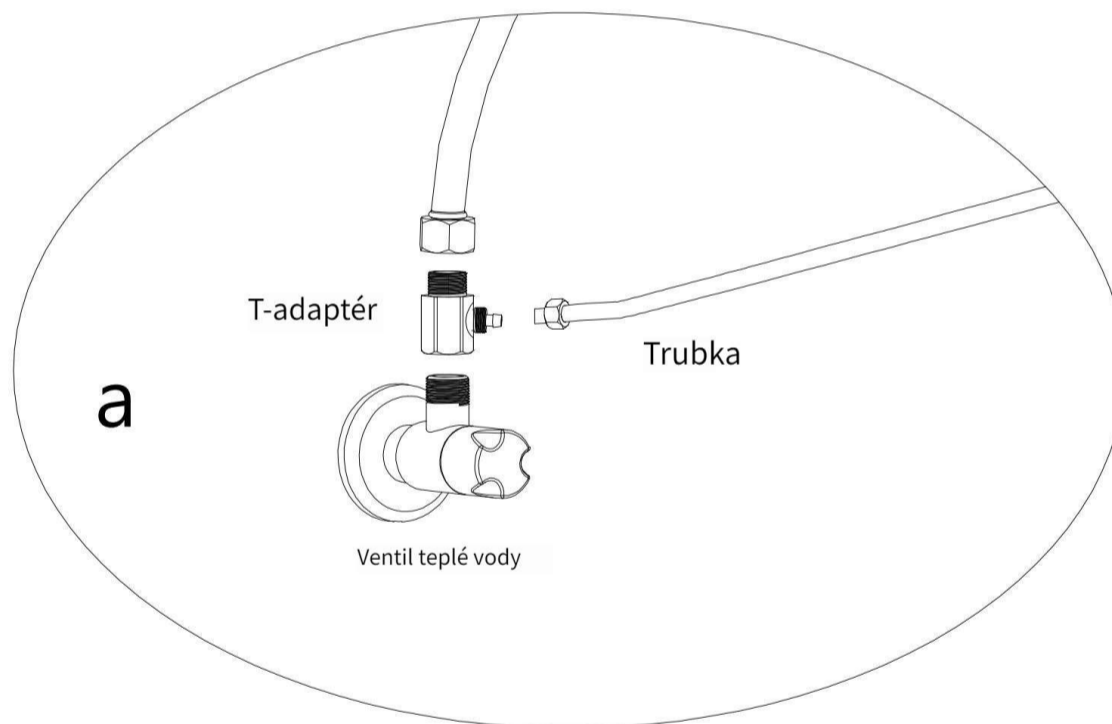
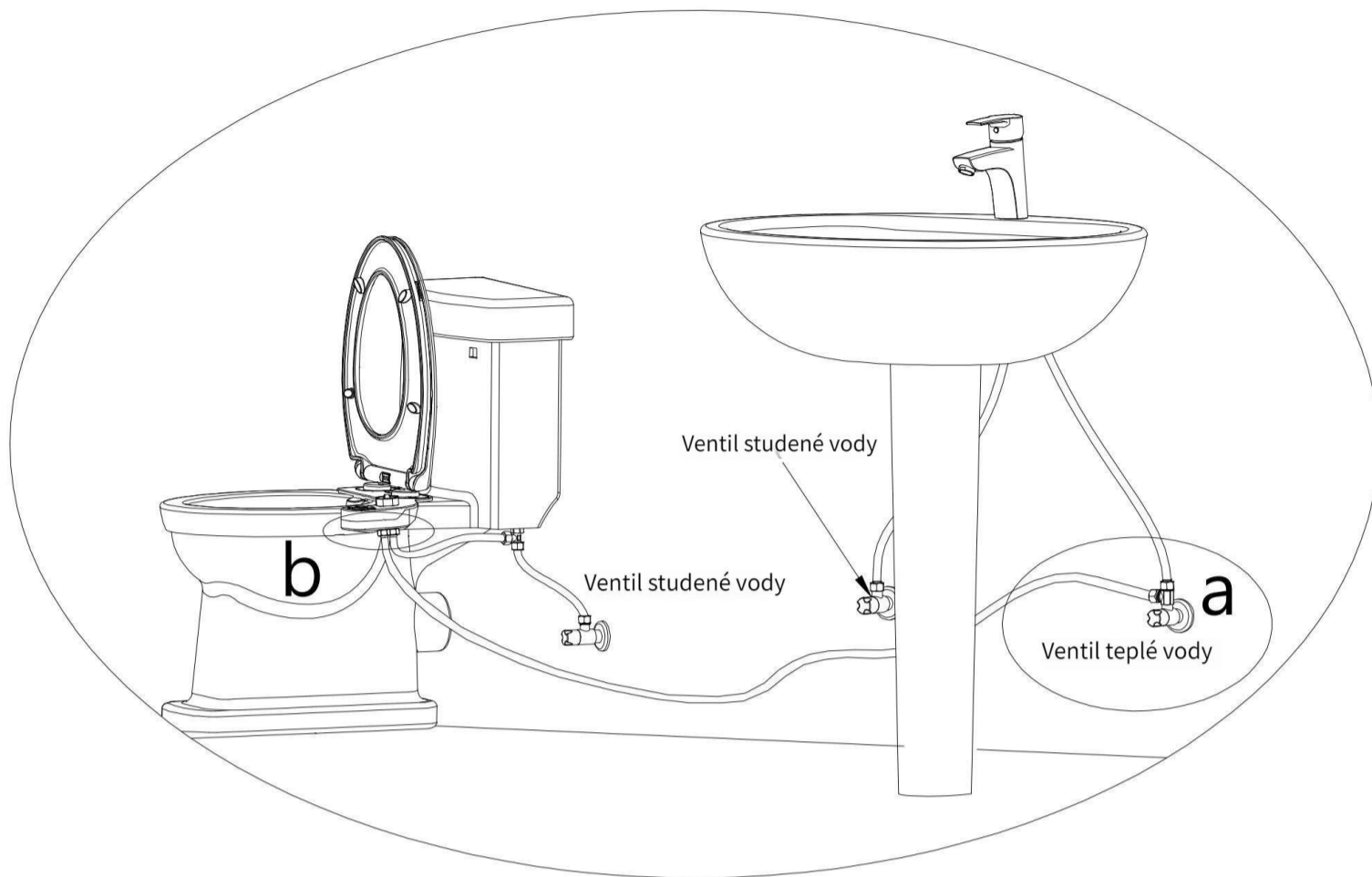

Rychlé vydání

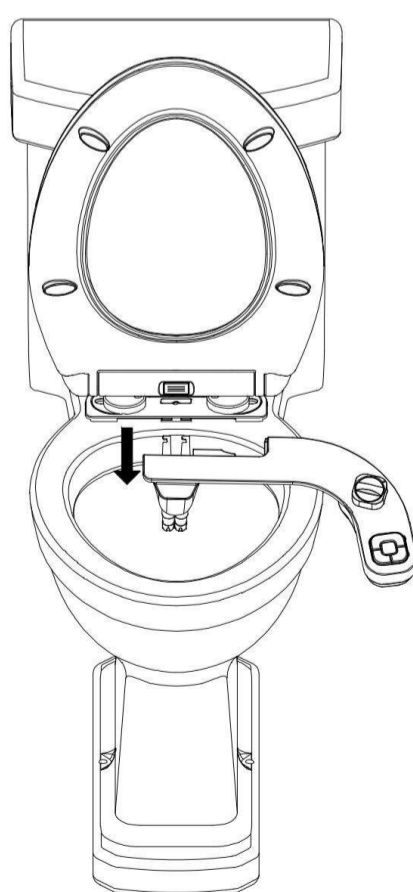
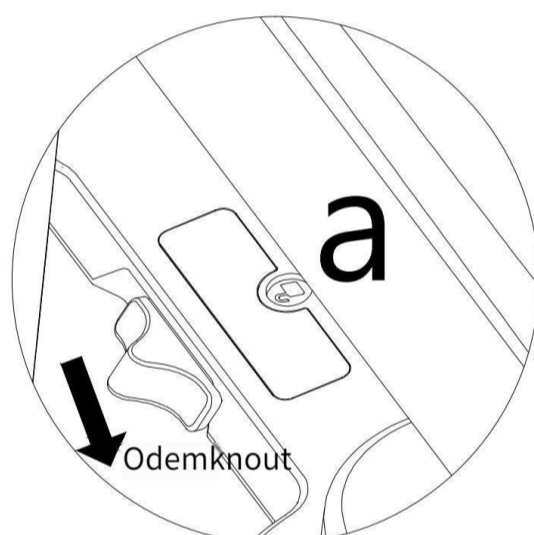
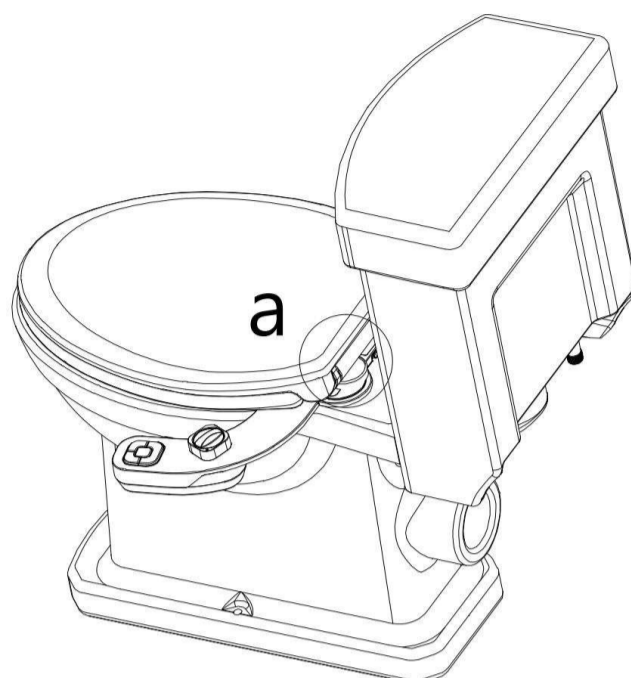

Rychlá instalace

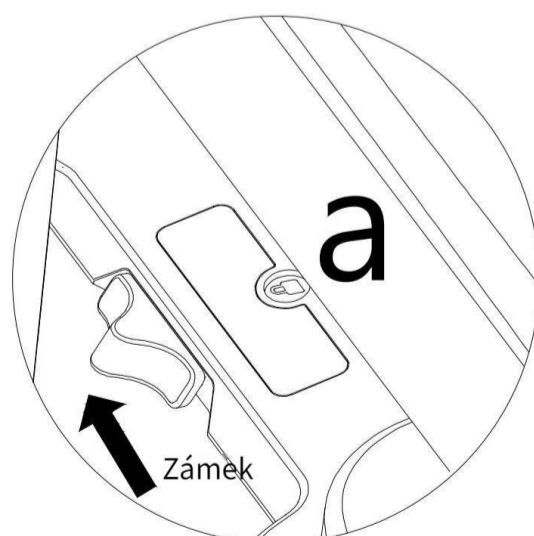
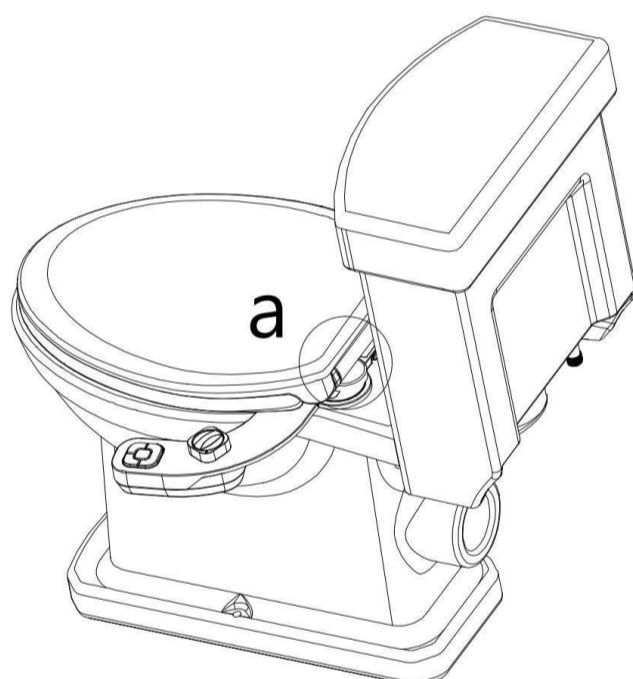
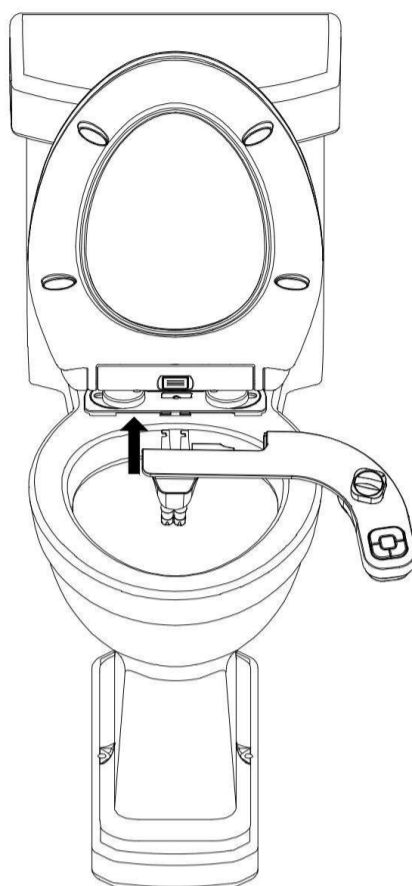

Provozní Instrukce



1. Pomocí tlačítka vyberte funkci trysky.

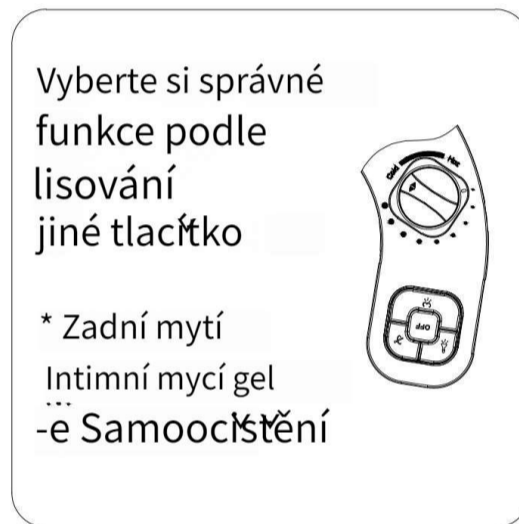
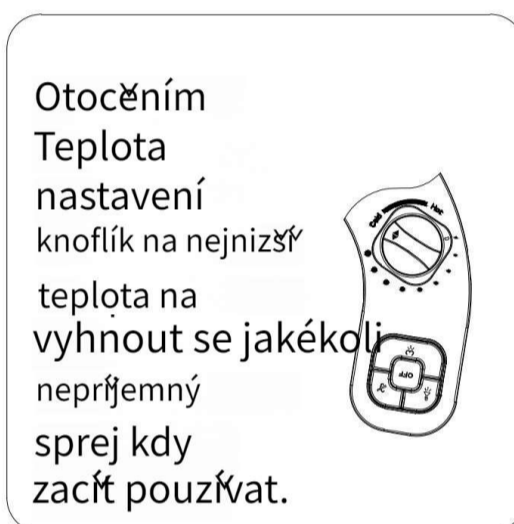
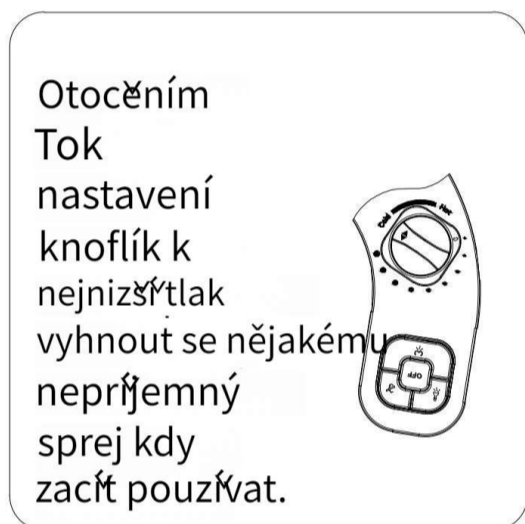

2. Upravte průtok vody.

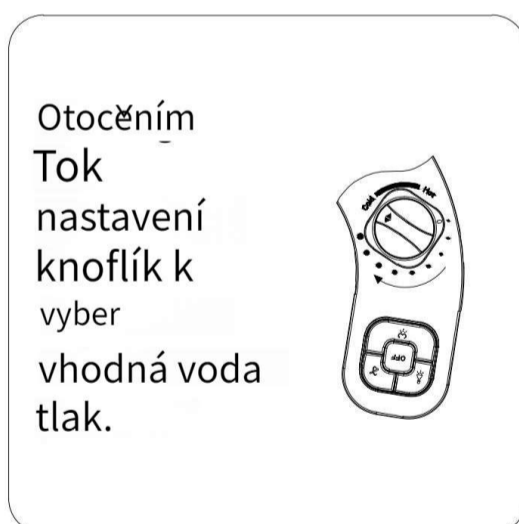
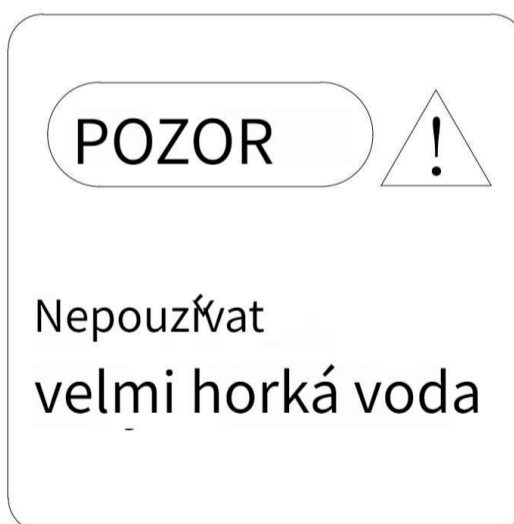
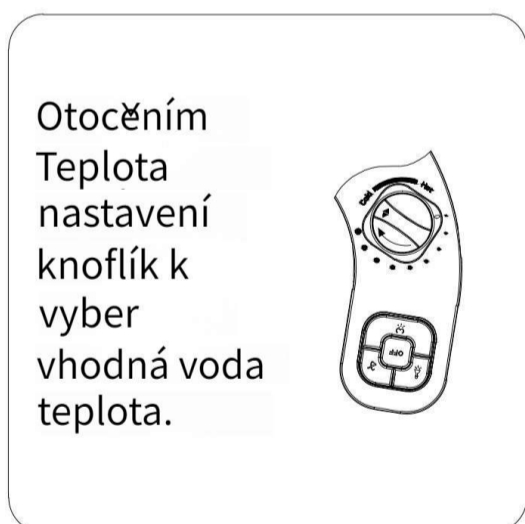

3. Používejte tak dlouho, jak je potřeba.

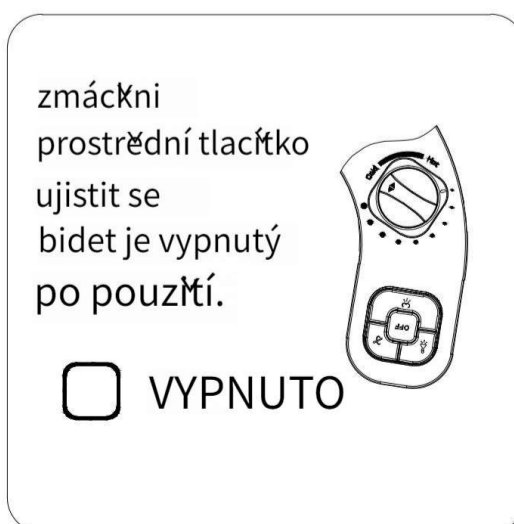
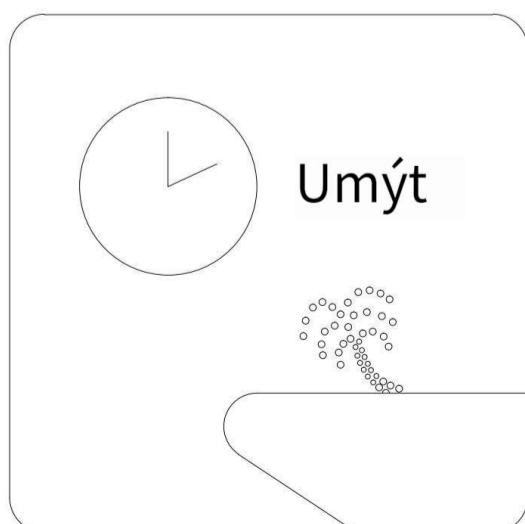

INSTRUKCJA OBSŁUGI

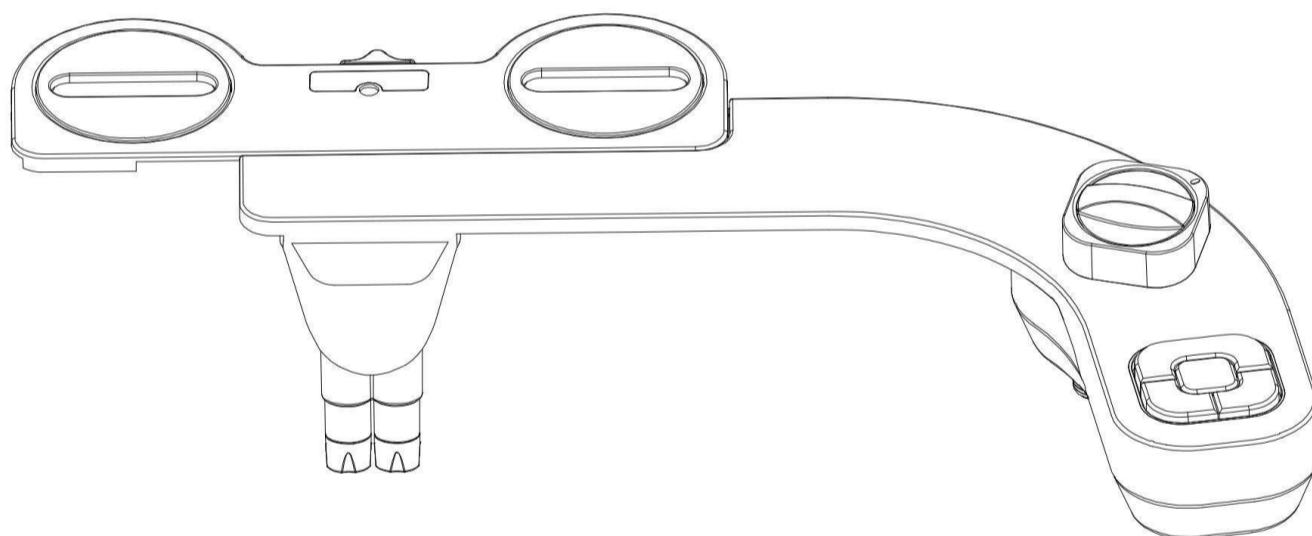

Nazwy i funkcje części

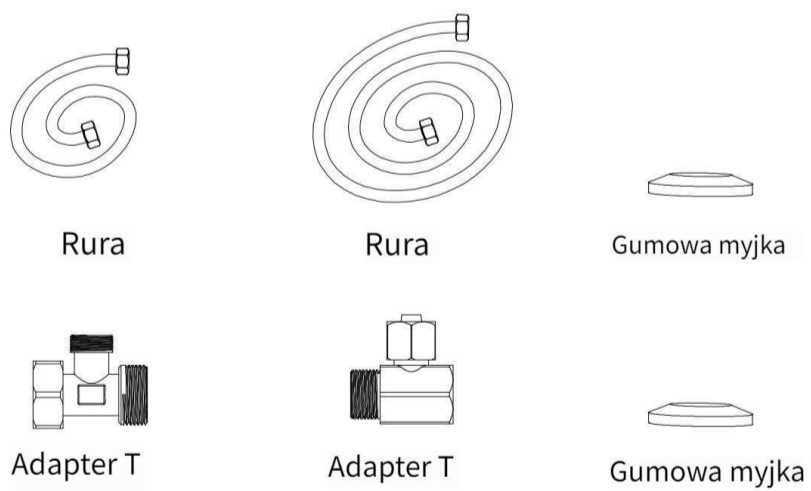
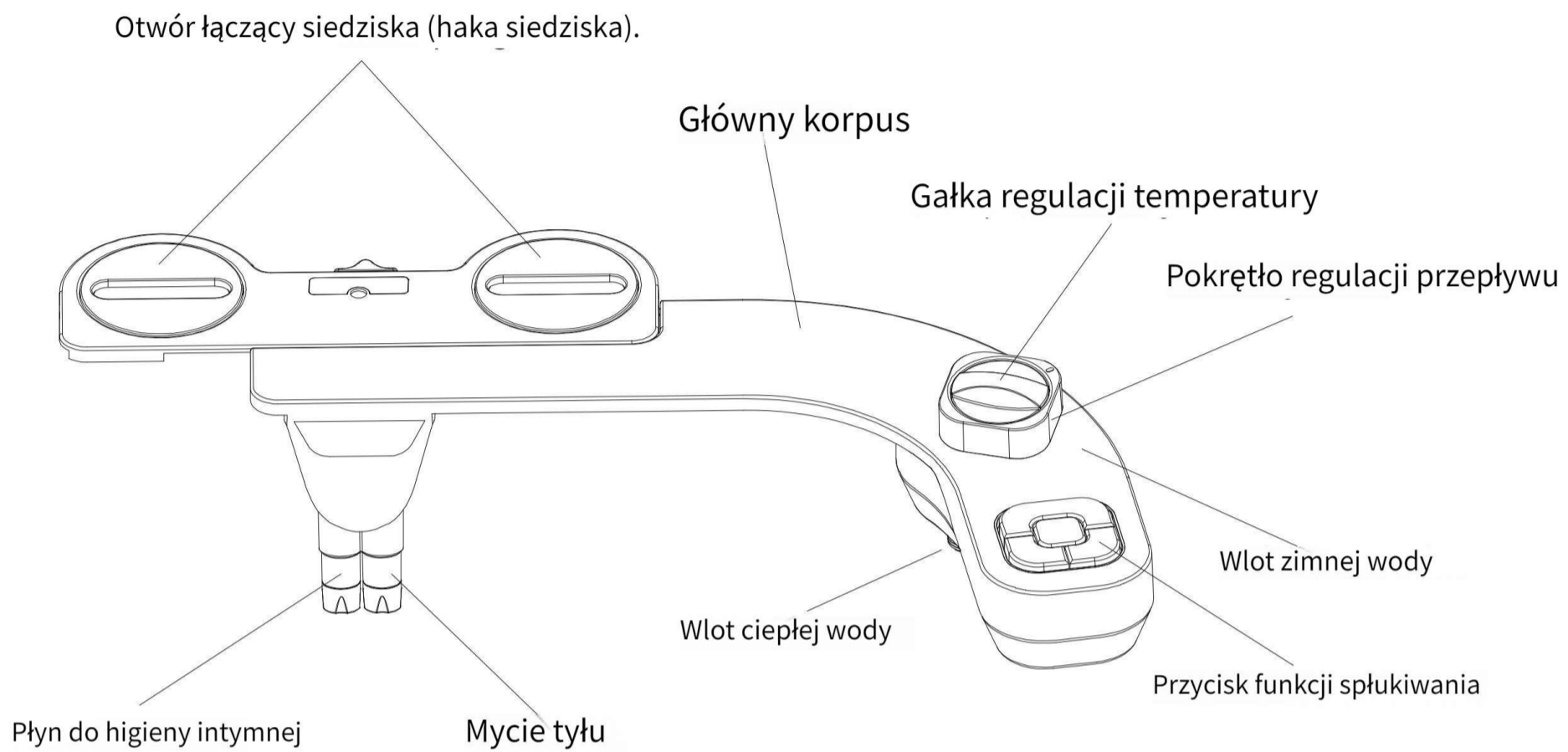

Narzędzia instalacyjne Needeo	
	
Klucz	Srúbokrét

Zainstaluj bidet



a

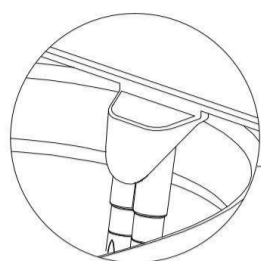

Wyreguluj dyszę pozycję i spróbuj zrobić to blisko brzeg toalety.

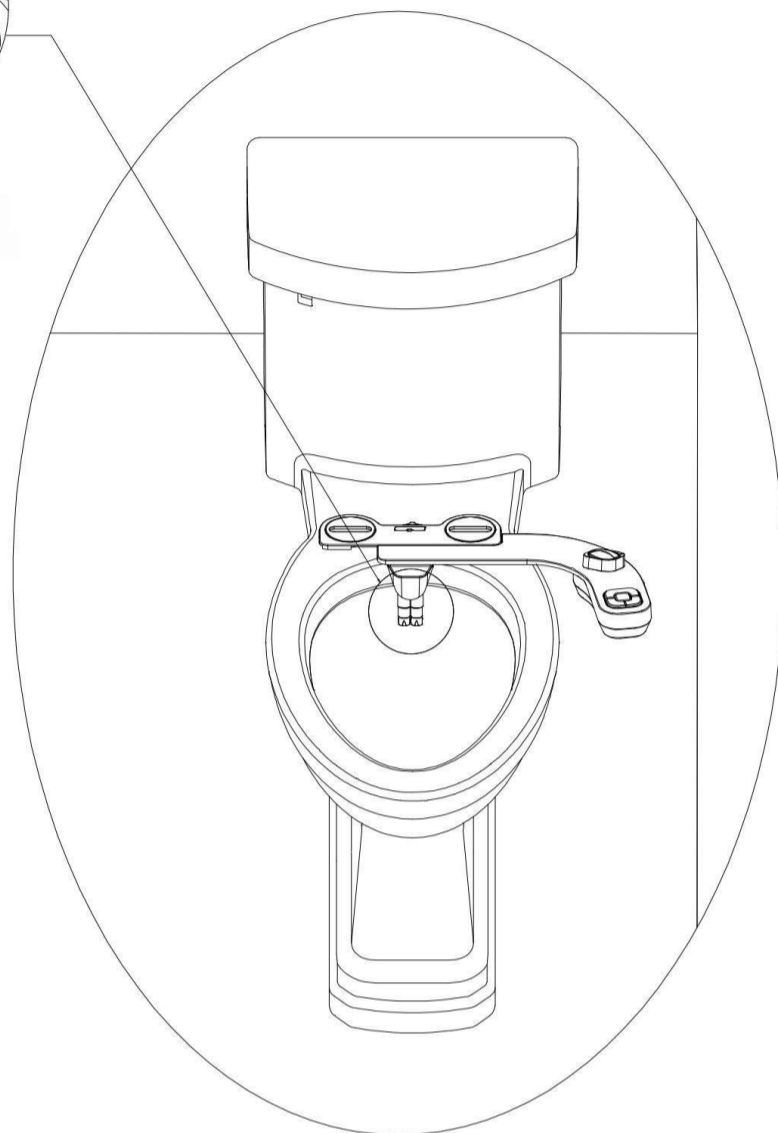

b

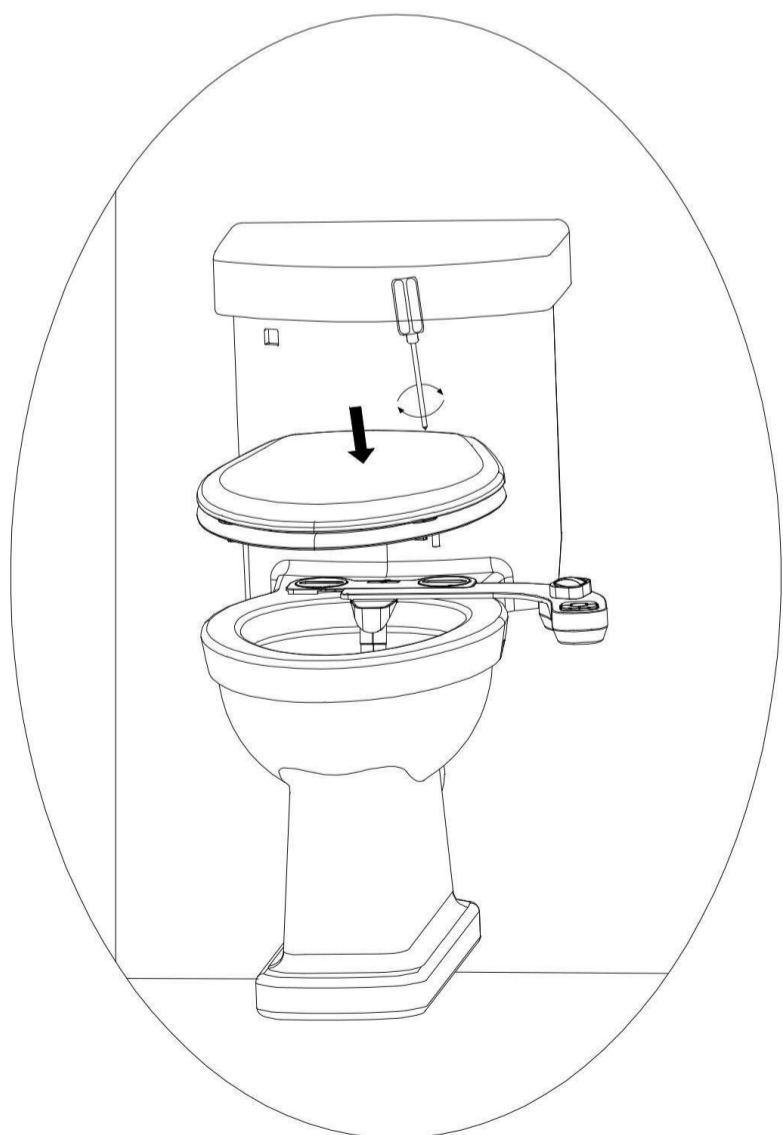

c

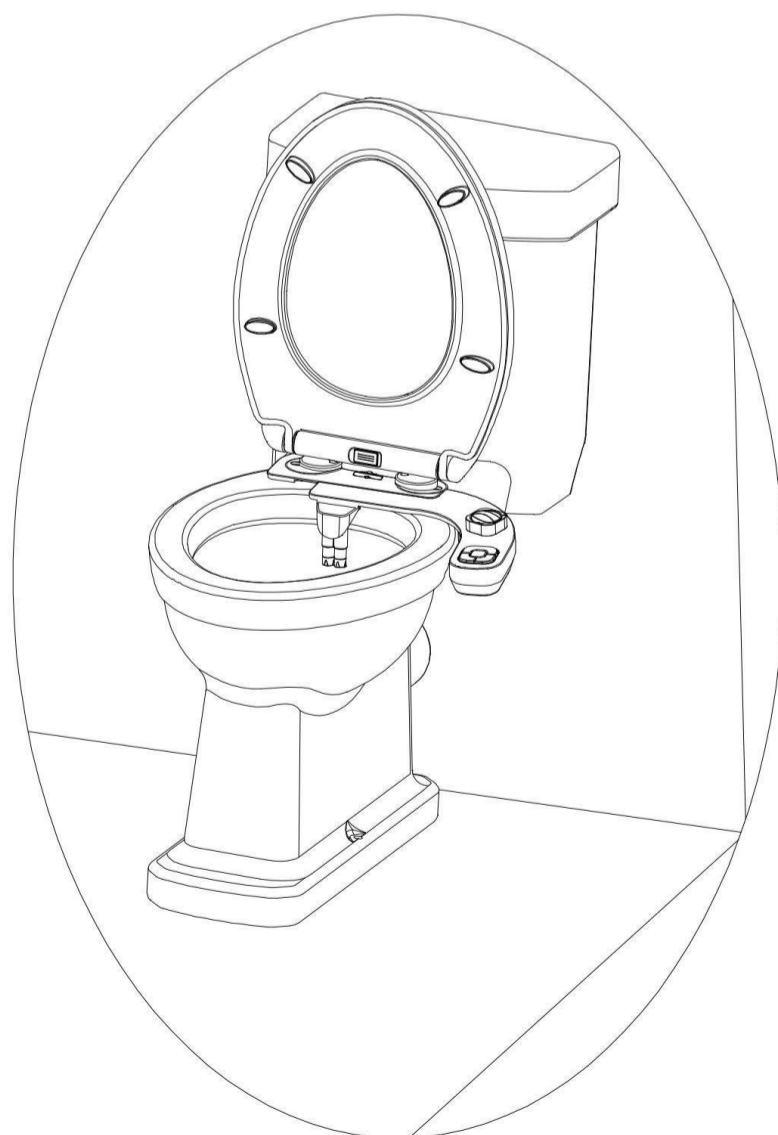

d

Podłącz zimną wodę

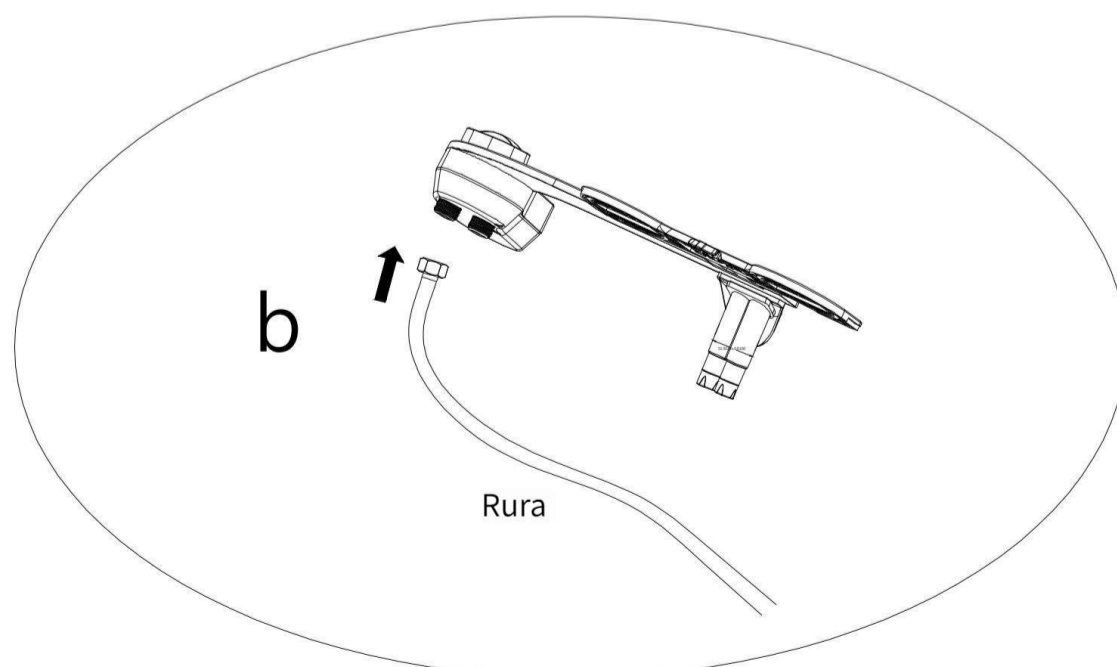
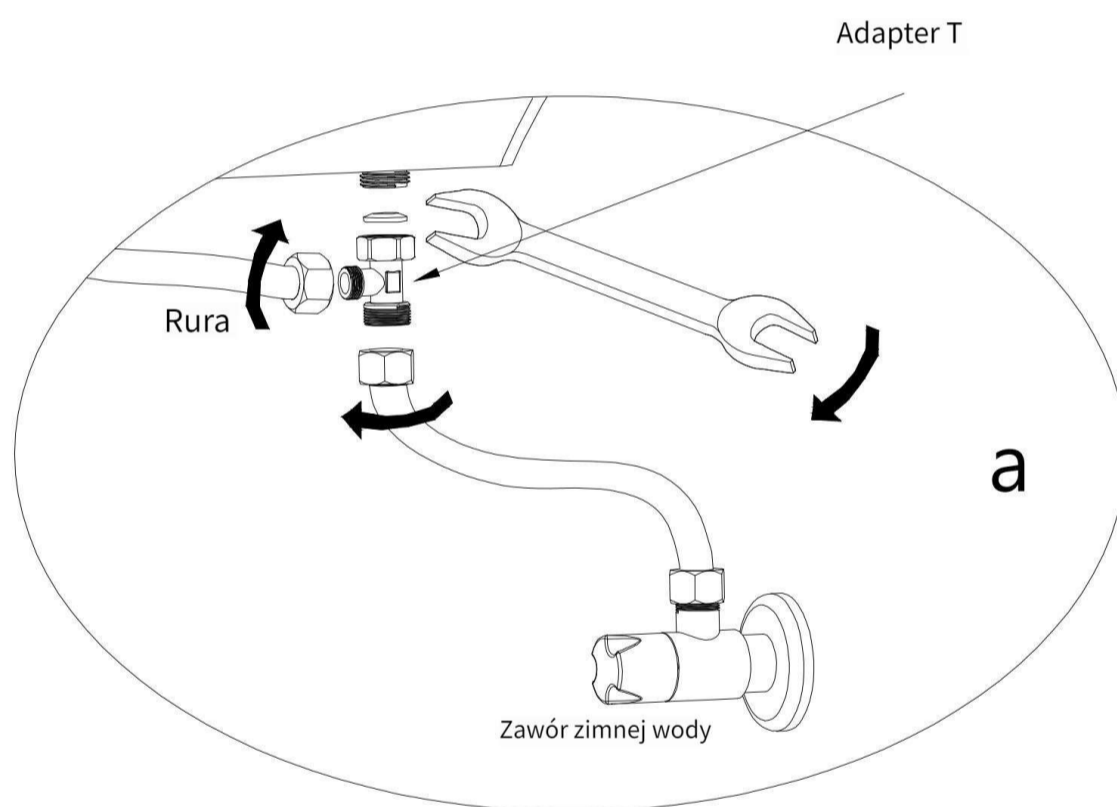
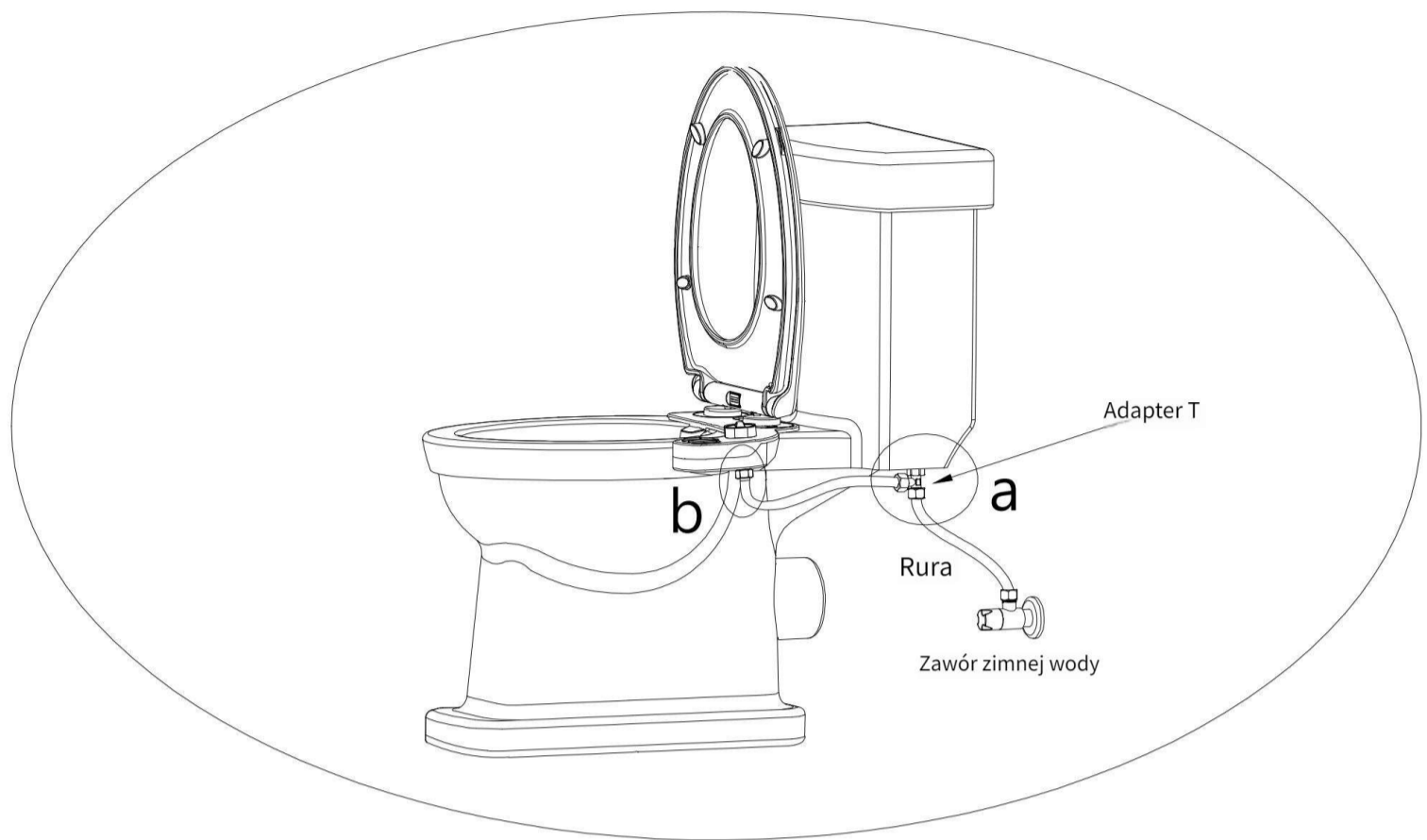

Podłącz ciepłą wodę

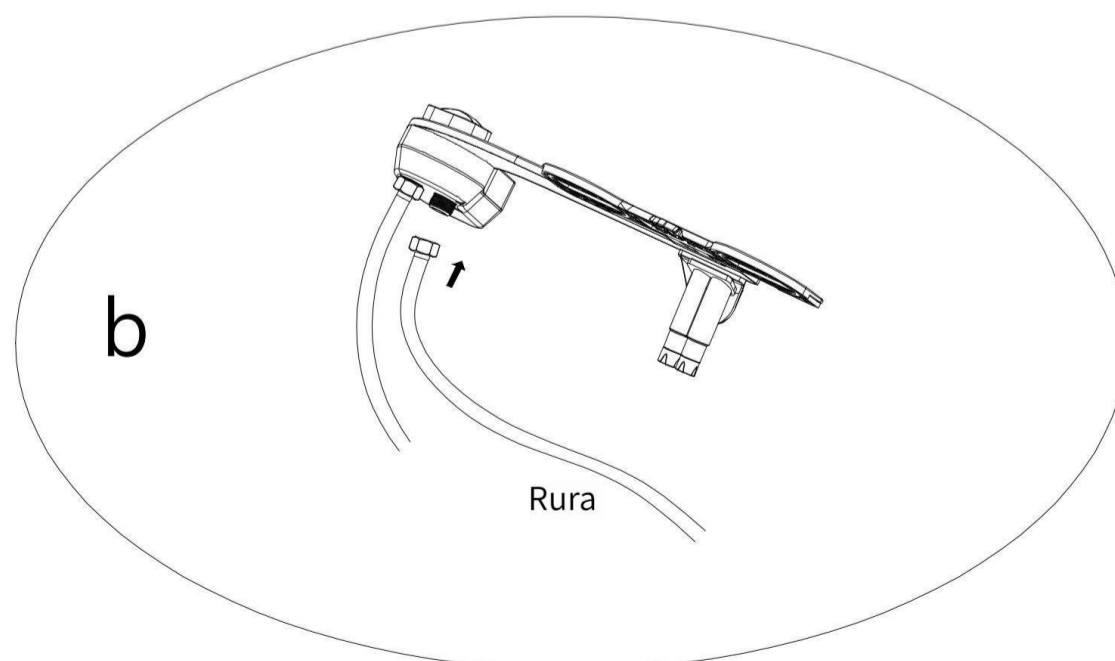
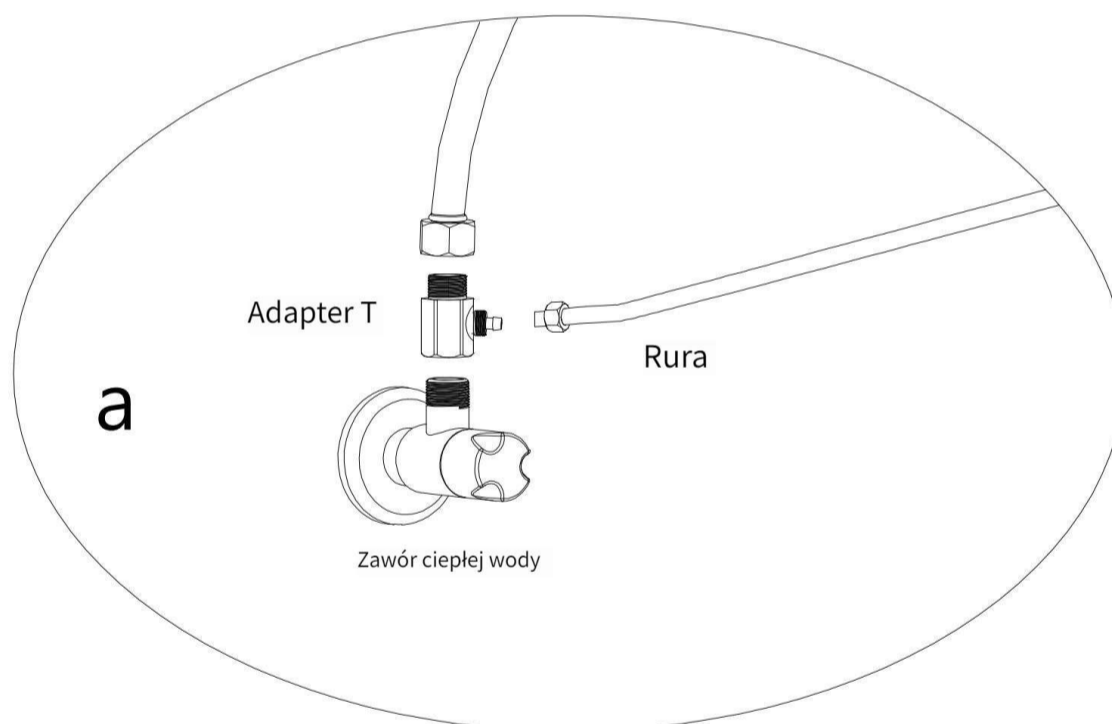
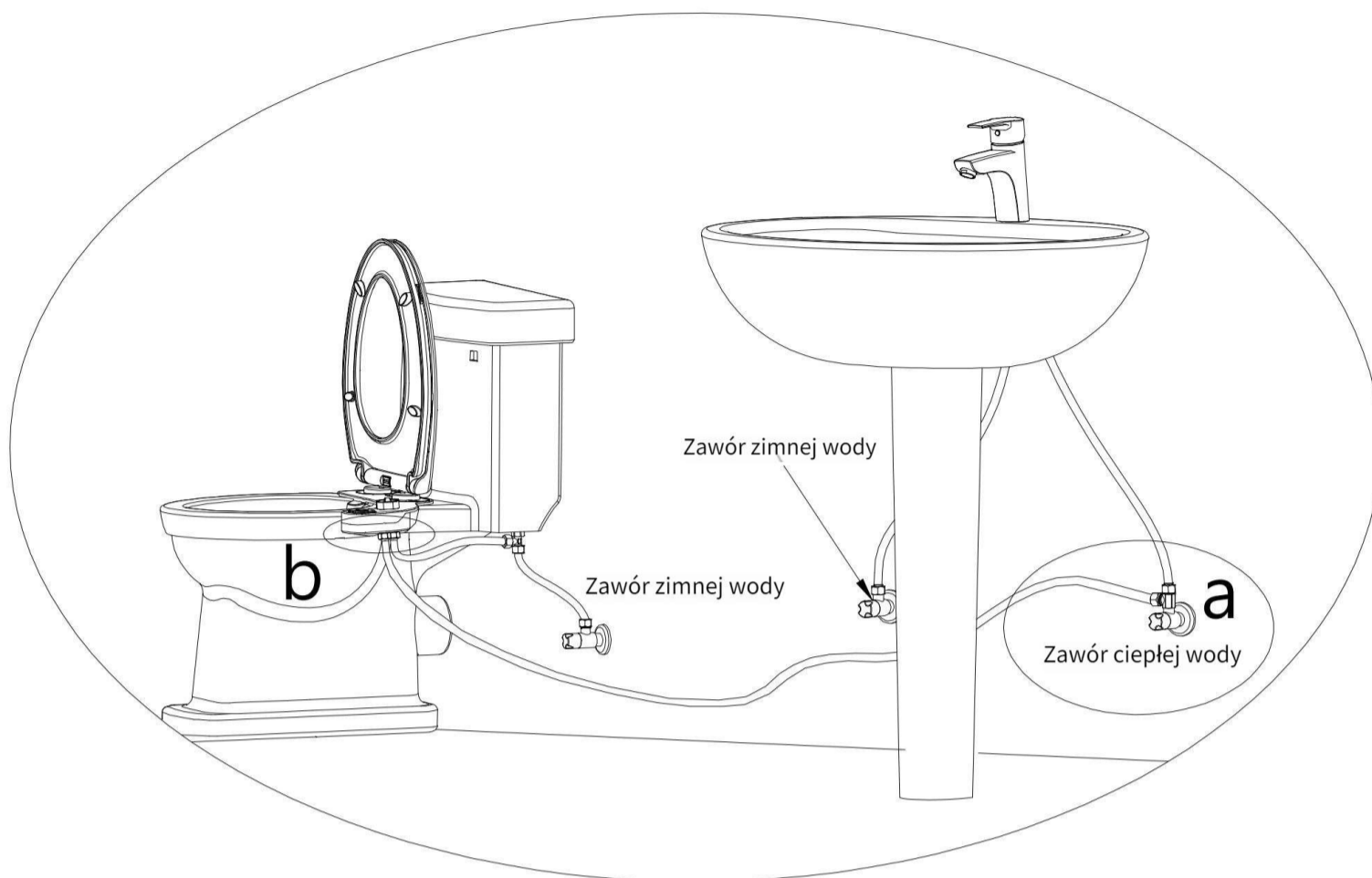

Szybkie wydanie

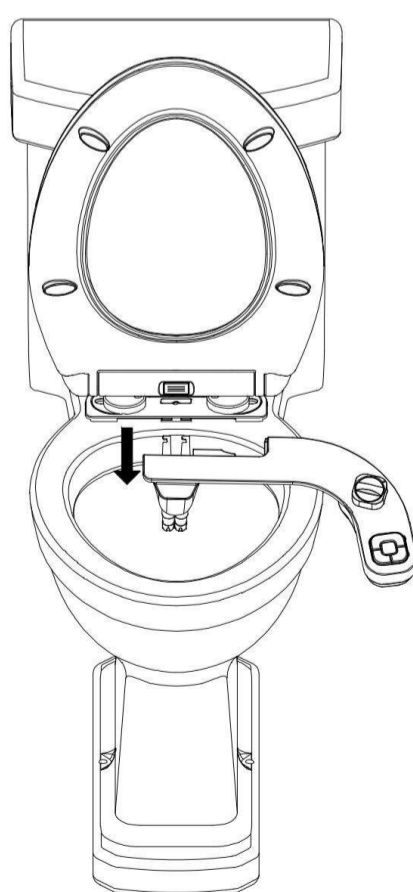
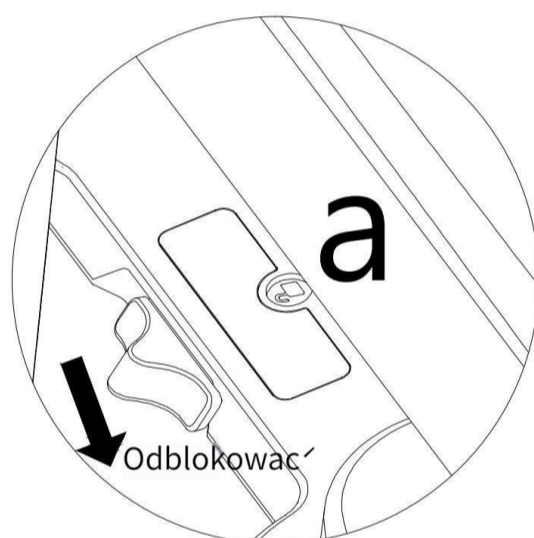
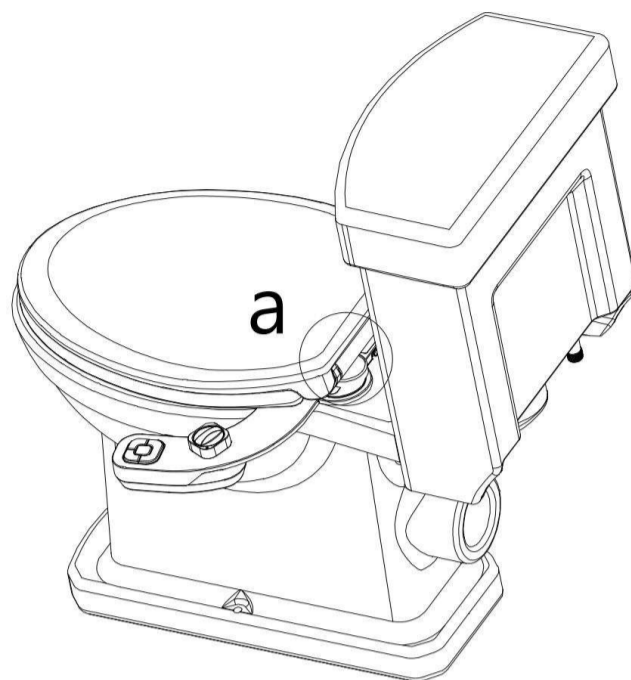

Szybka instalacja

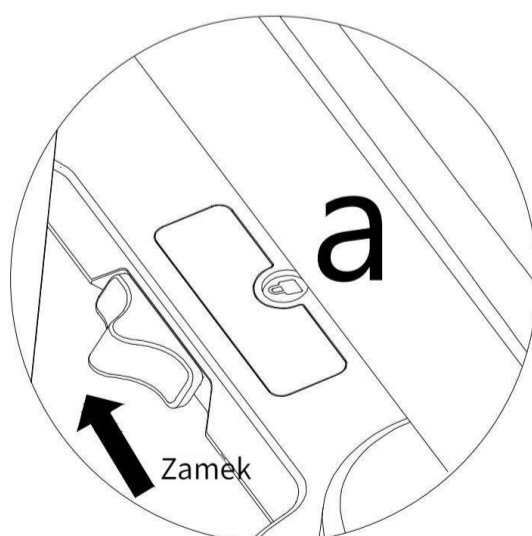
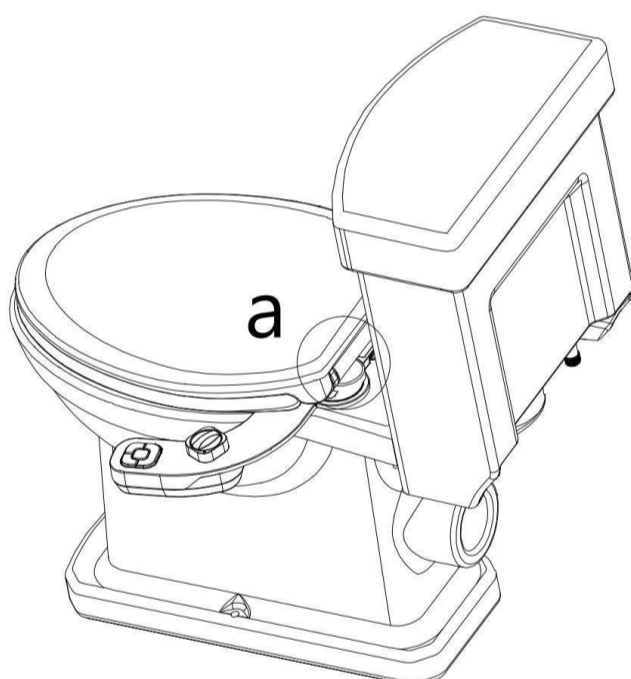
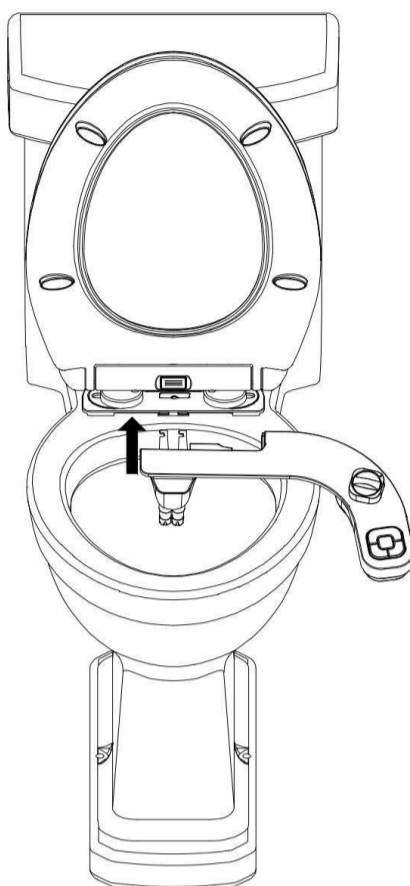

Operacyjny instrukcje



1. Wybierz funkcję dyszy za pomocą przycisku .

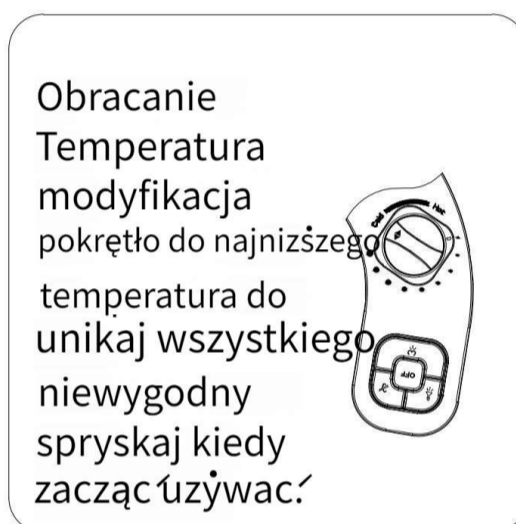
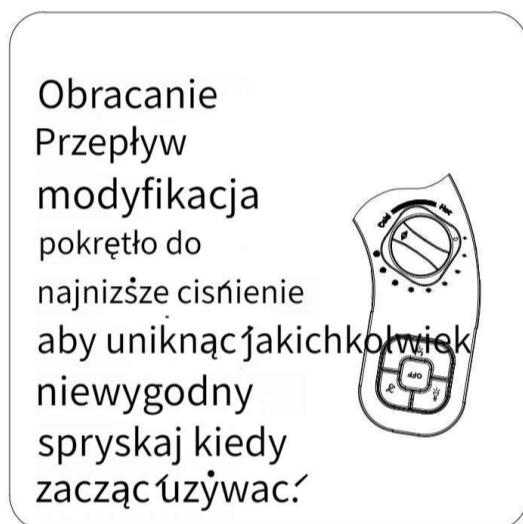

2. Wyreguluj przepływ wody.

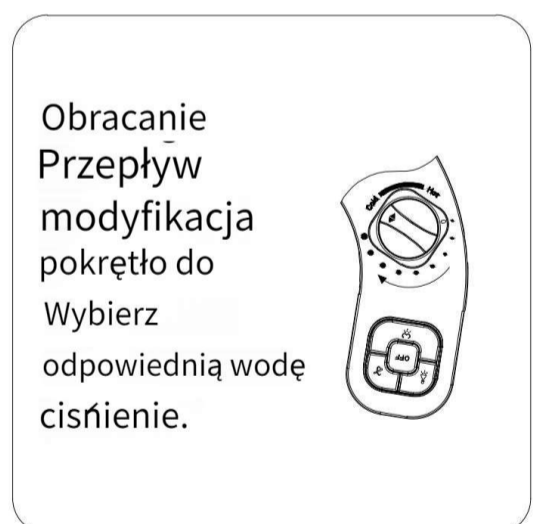
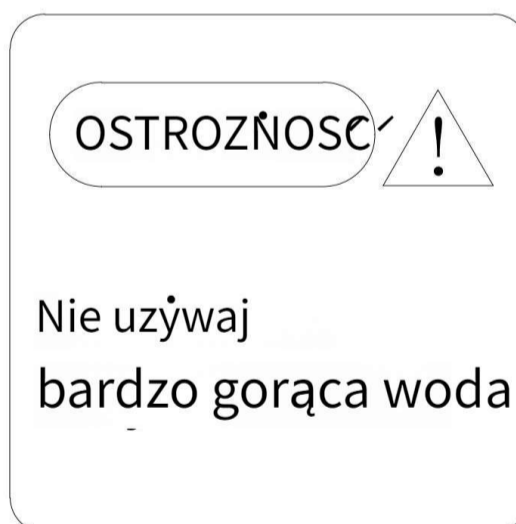

3. Używaj tak długo, jak potrzeba.

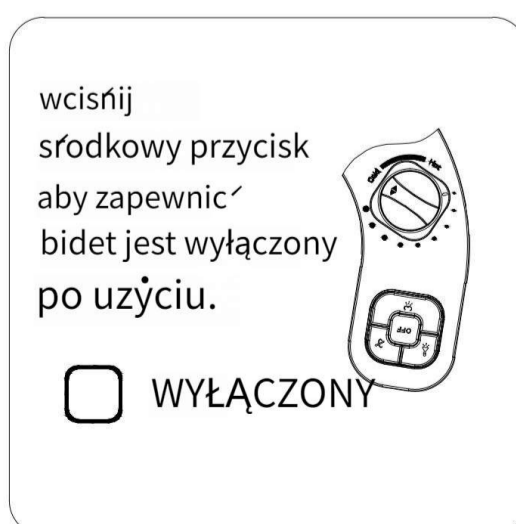

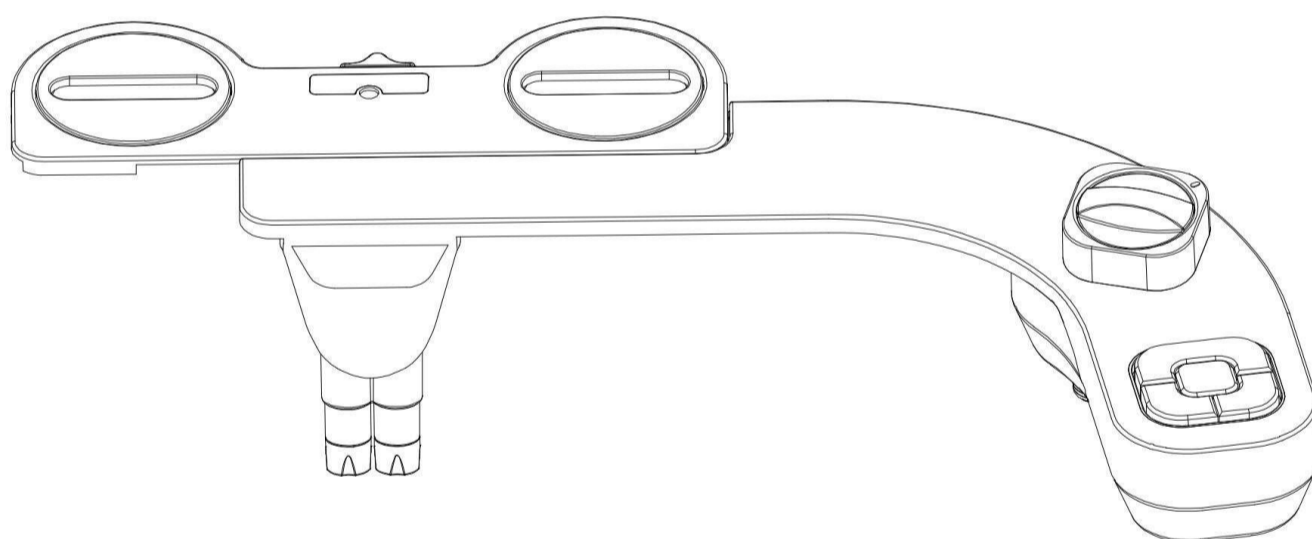

HANDLEIDING

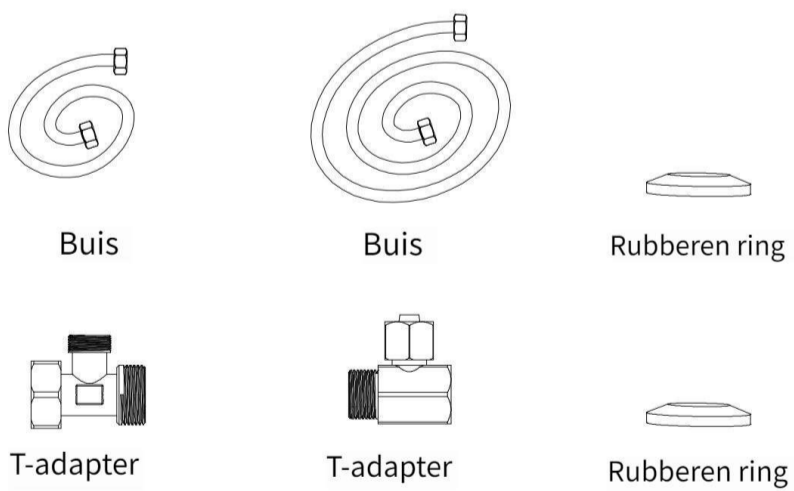
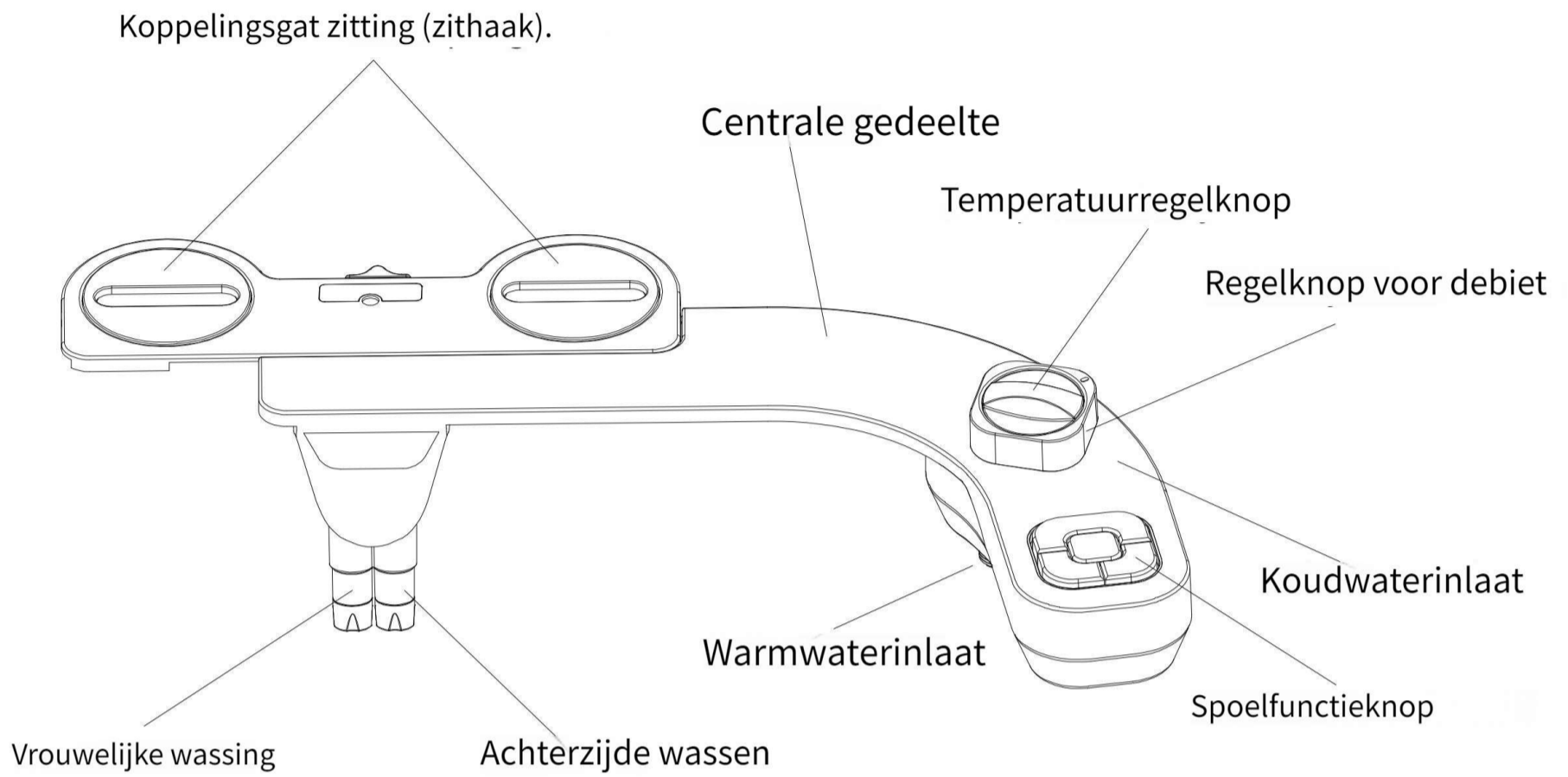

Namen en functies van onderdelen



Benodigde installatiegereedschappen	
	
Moersleutel	Schroevendraaier

Installeer het bidet

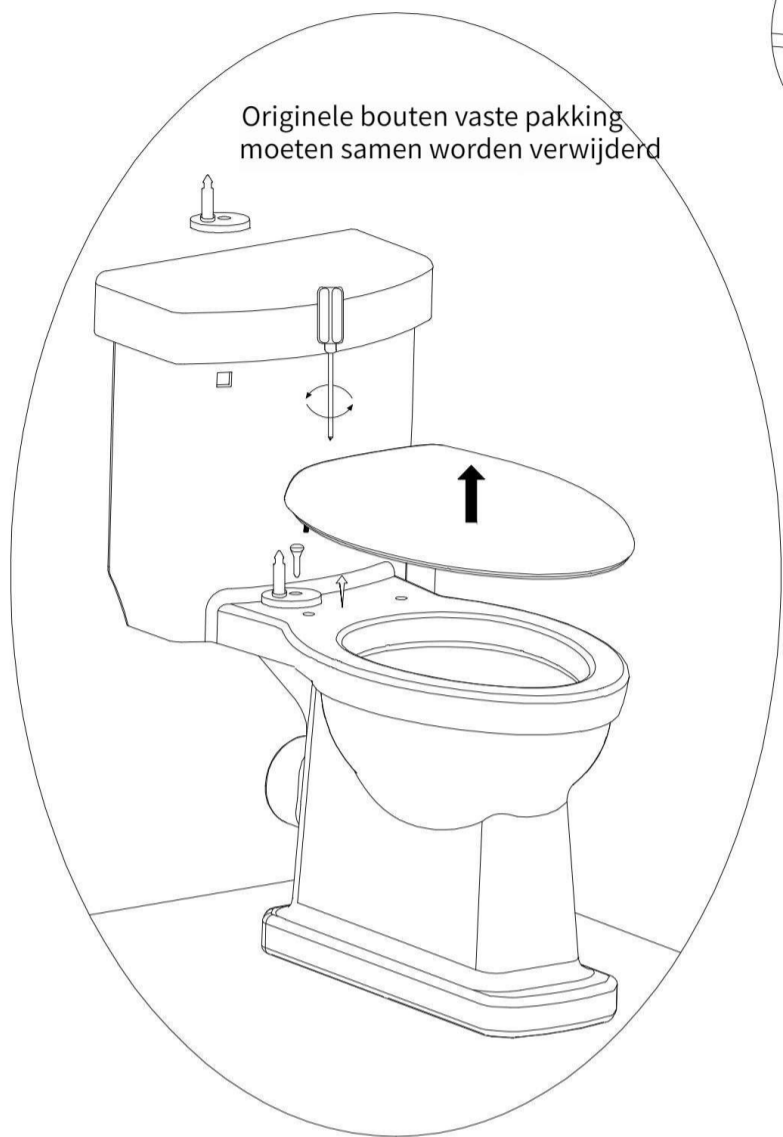

a

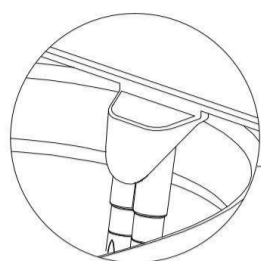

Pas het mondstuk aan positioneren en proberen maak het dicht bij de rand van het toilet.

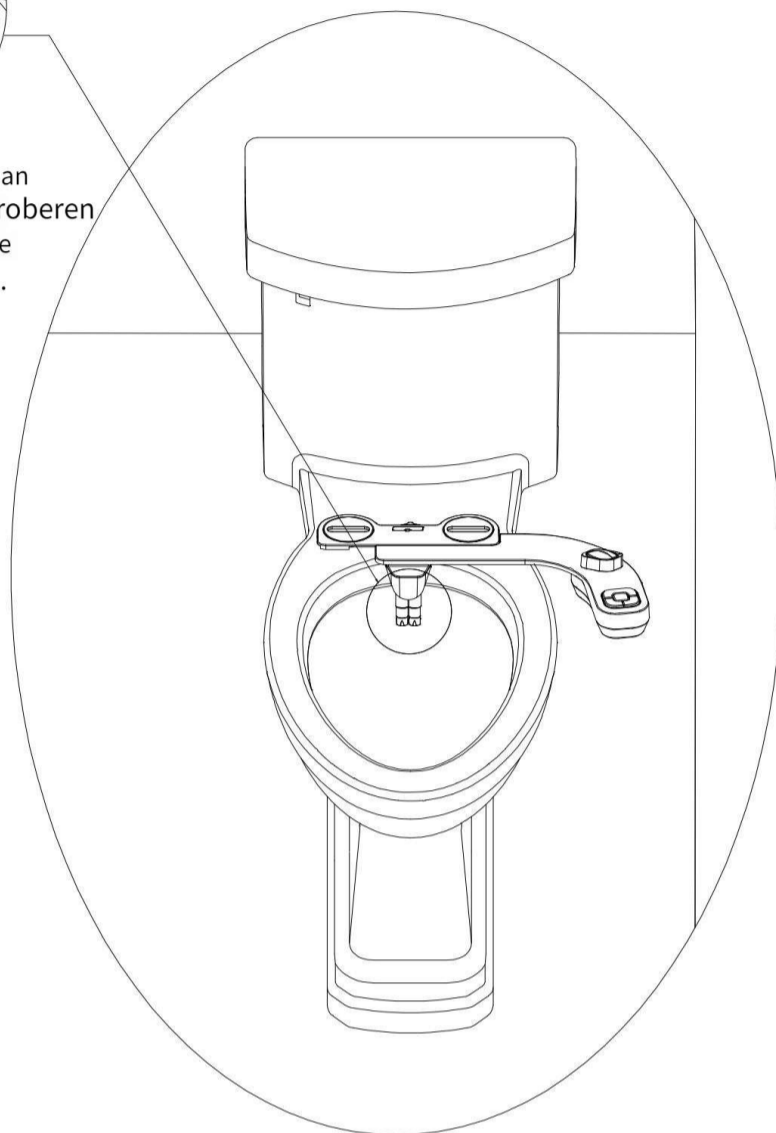

b

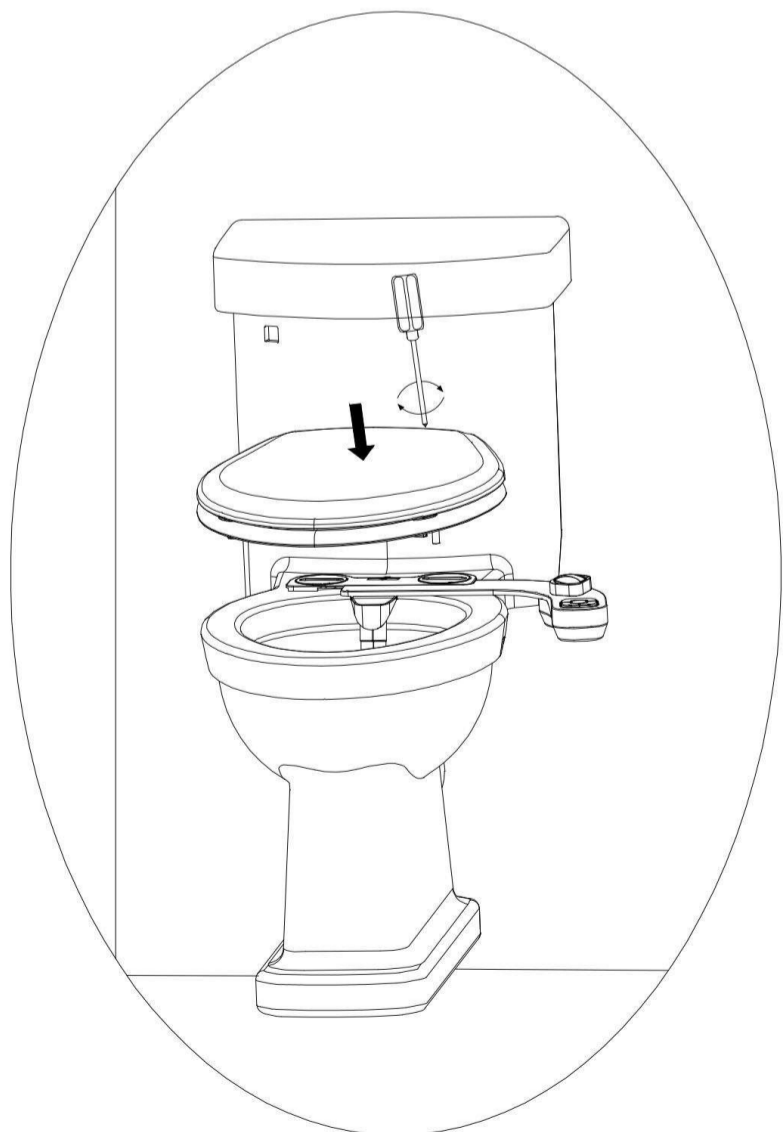

c



d

Sluit koud water aan

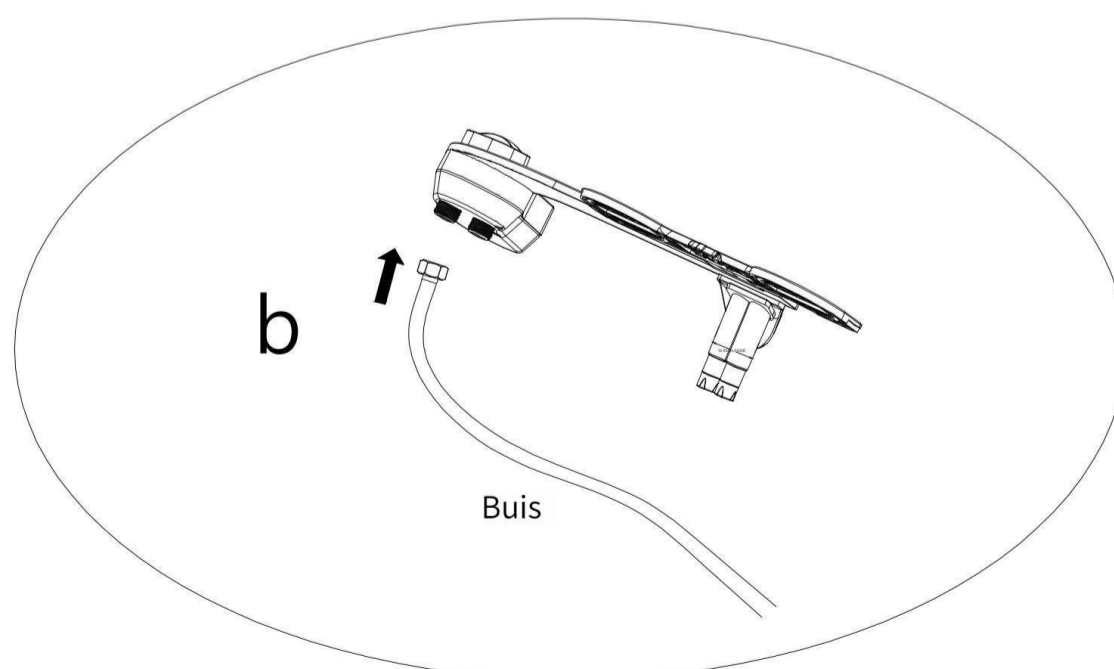
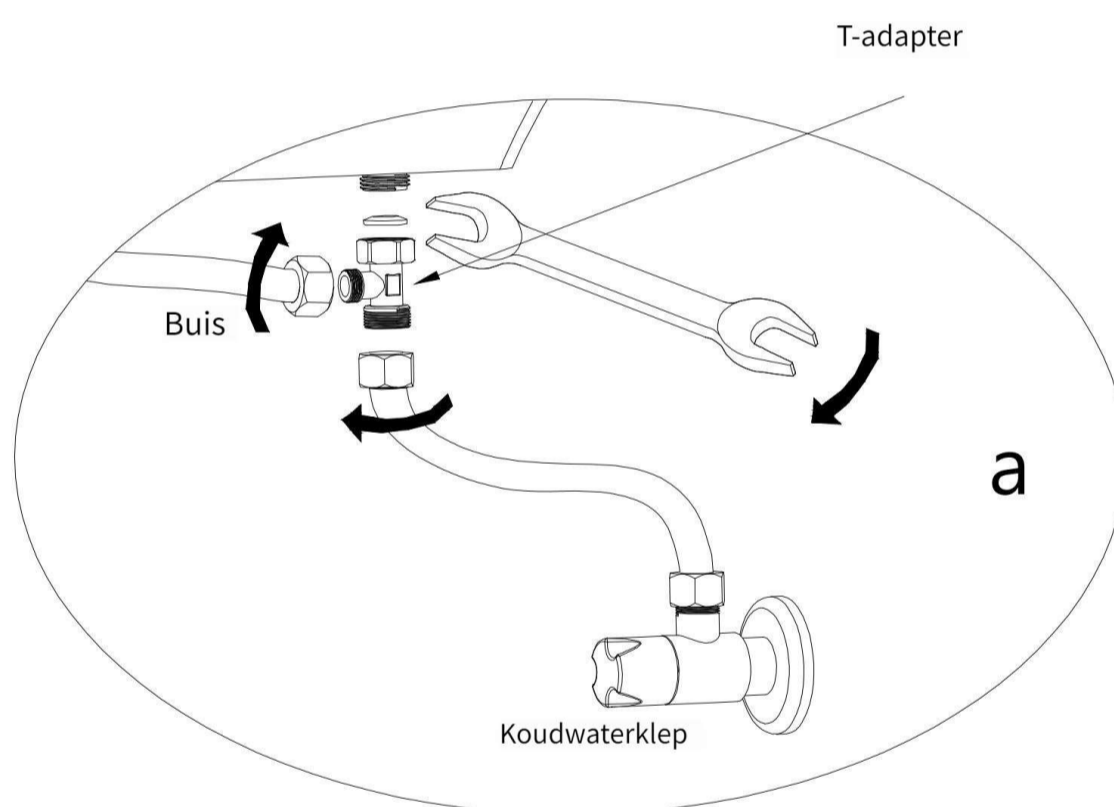
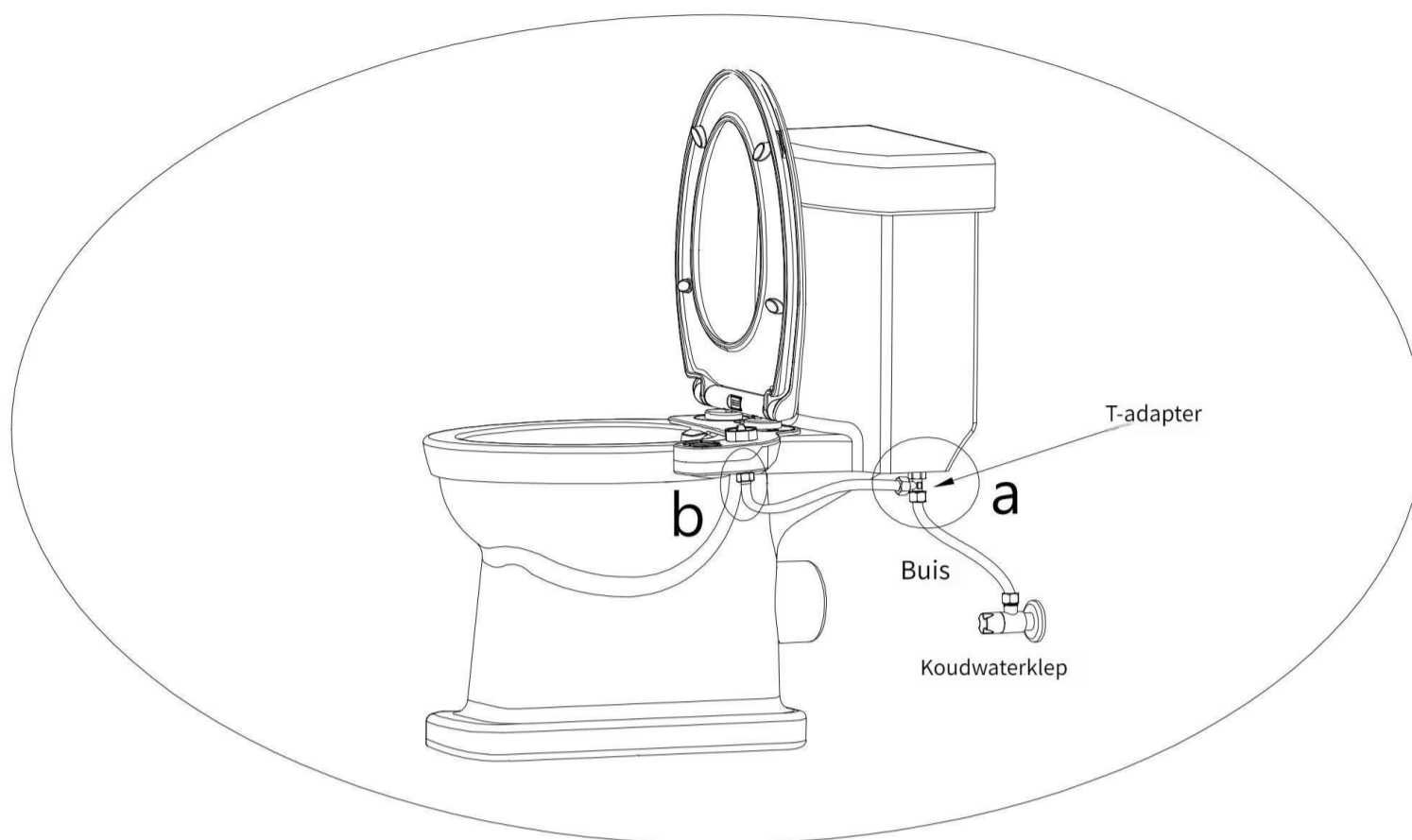

Verbind warm water

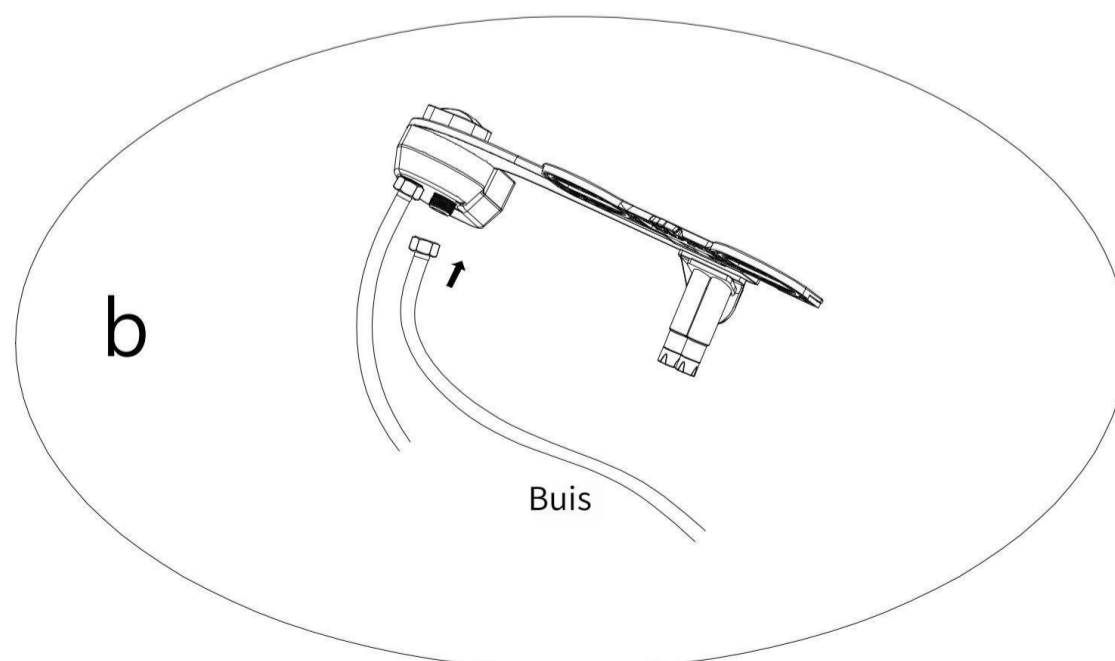
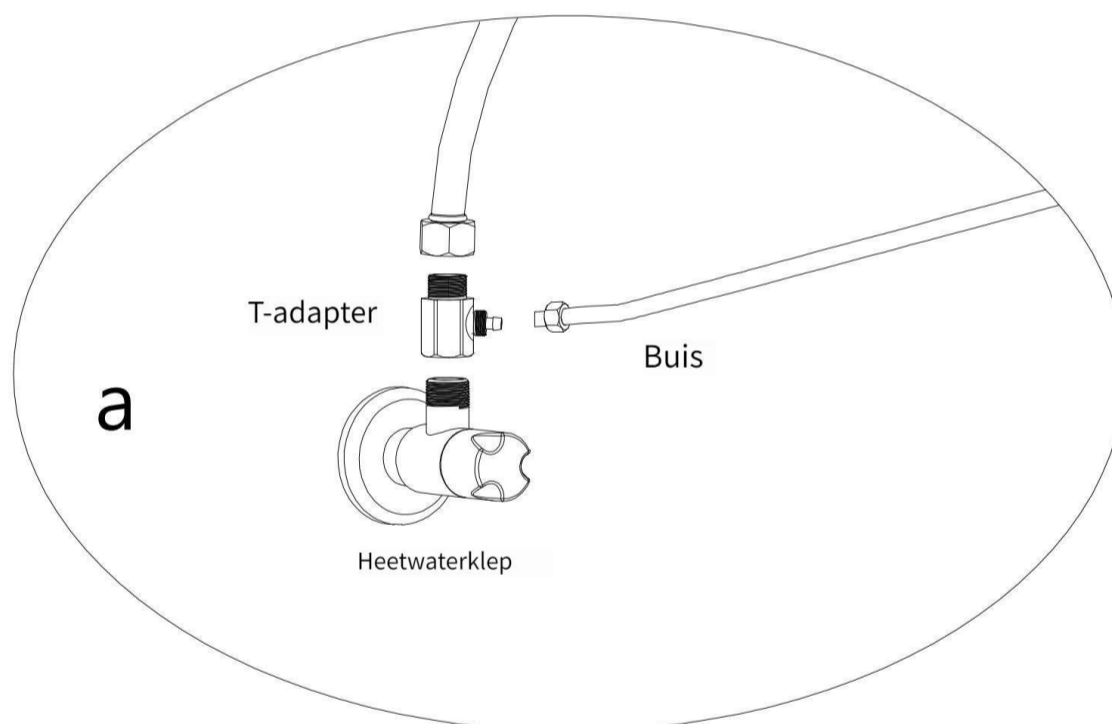
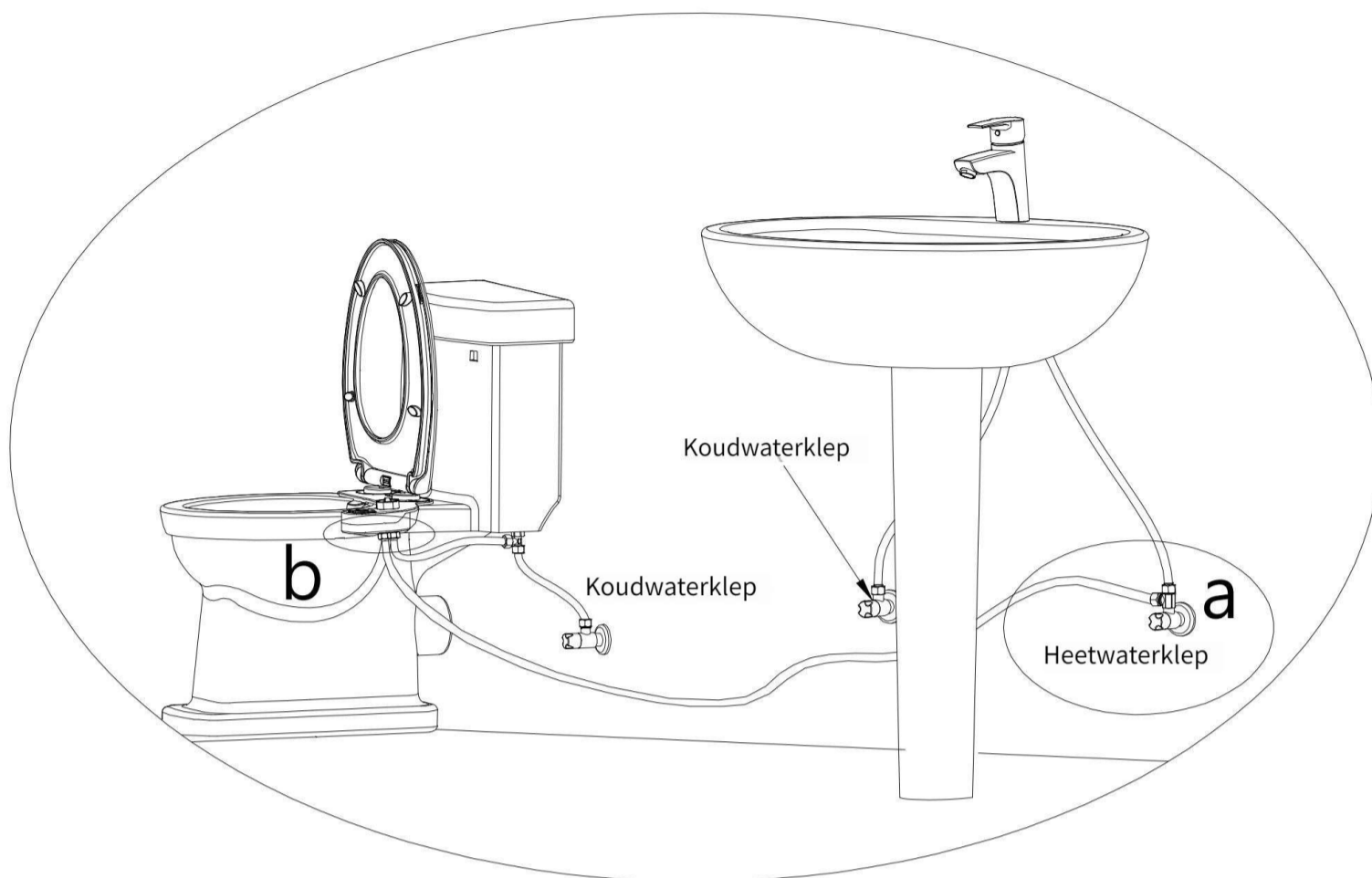

Snelle release

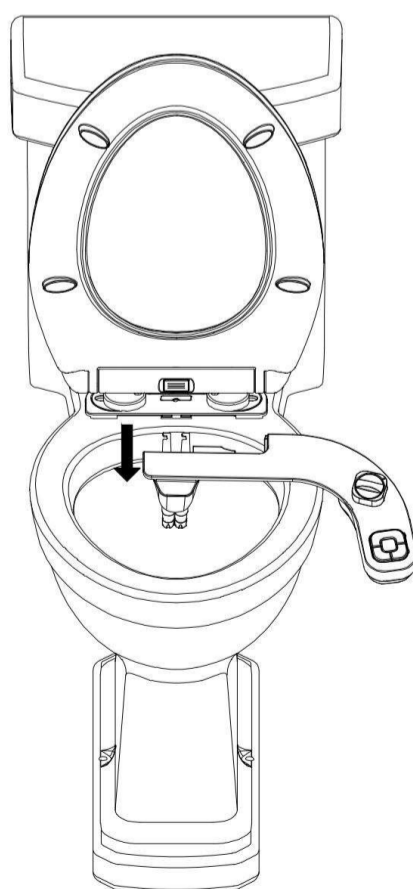
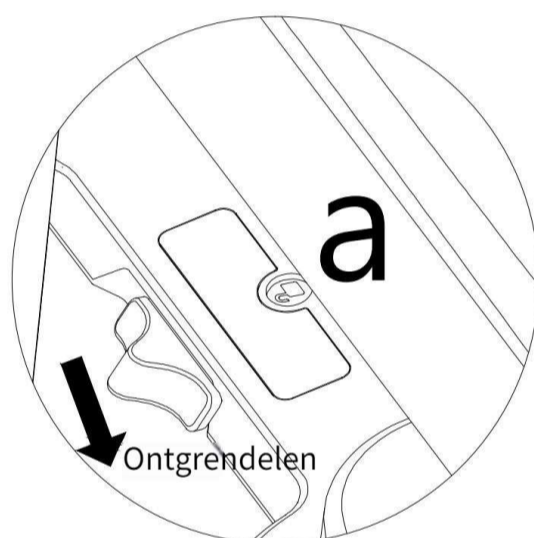
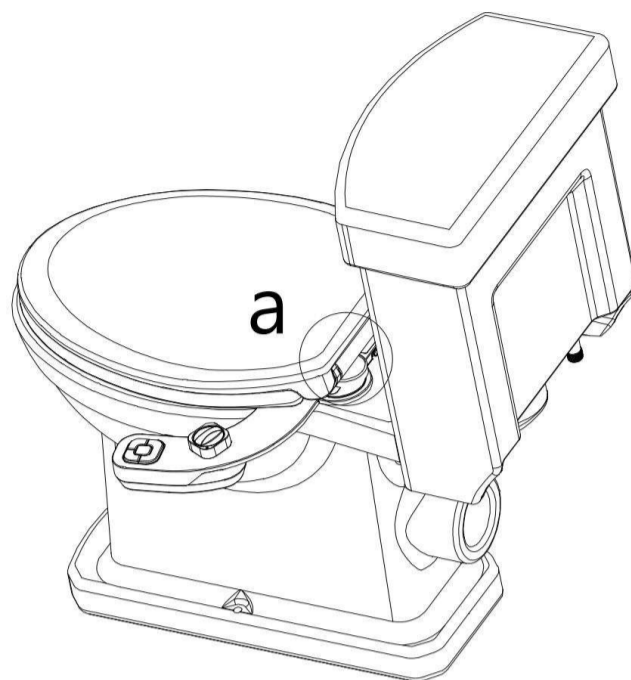

Snelle installatie

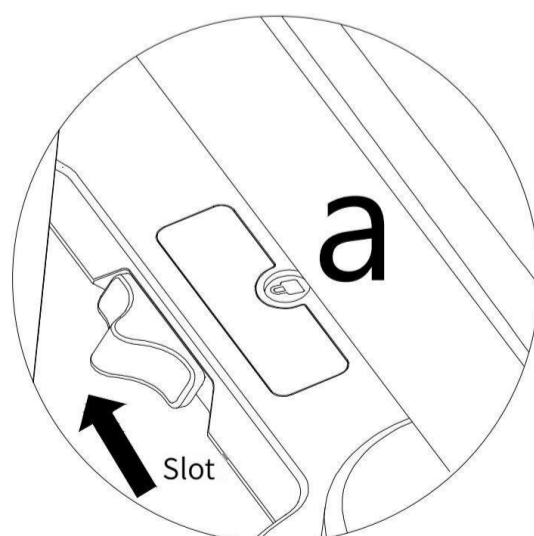
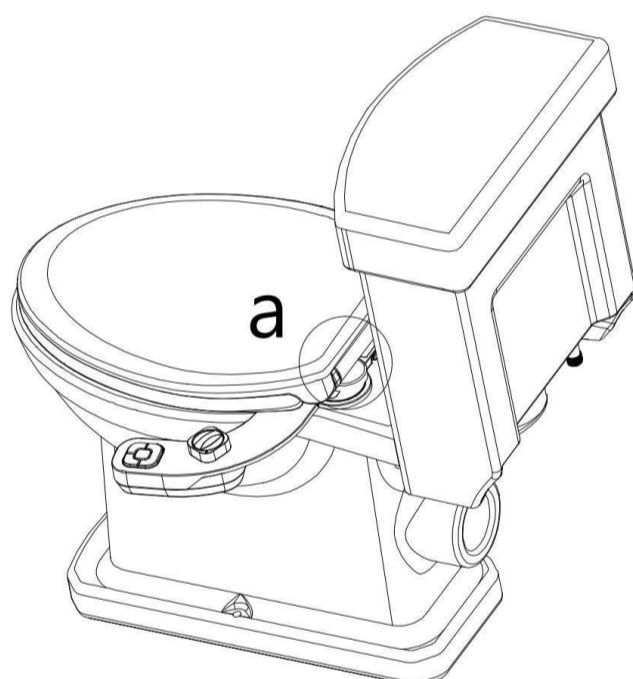
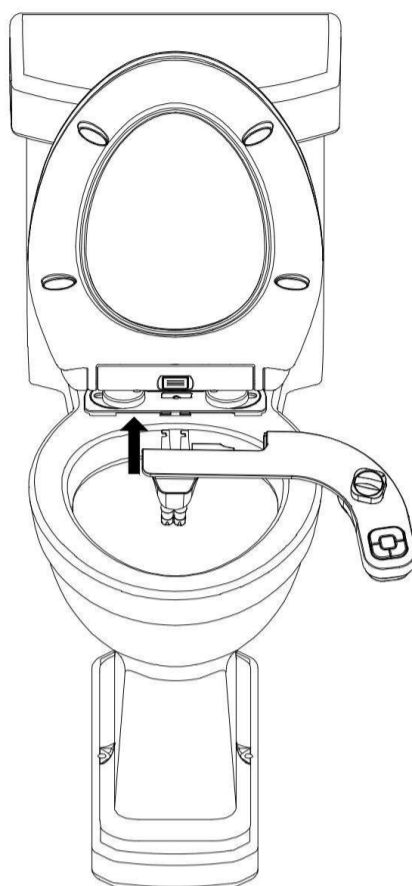

Operatione**re**structies



1. Selecteer de spuitmondfunctie met de knop.



2. Pas de waterstroom aan.

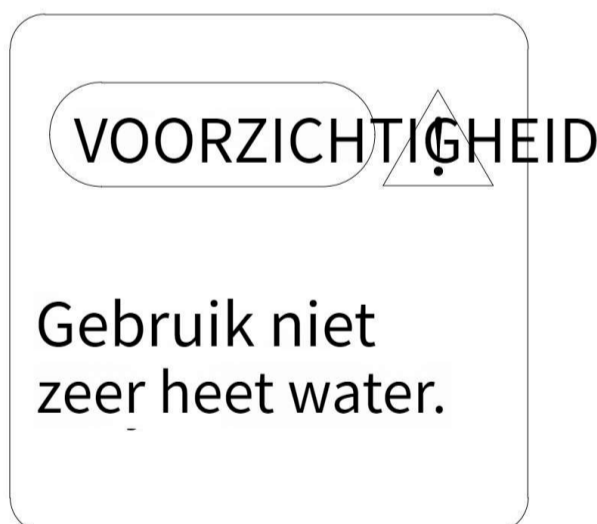

3. Gebruik zo lang als nodig is.

